



Products and systems for Customer Flow Management

CONTENT

Qmatic systems	page 4
Software	page 6
Ticket printers/Pedestals/Stands and brackets/Tickets and card readers	page 25
Displays/Sign boards/Voice units	page 35
Workstation terminals	page 44
Interfaces	page 47
Linear queue systems	page 48

About Qmatic

Qmatic invented Customer Flow Management (CFM) and we are today the world leaders in our field. CFM is the process of managing customer flow and experience from their initial contact with you to final service delivery.

The CFM process helps organisations increase productivity and profitability whilst improving customer and staff experiences and the data and insights we generate drive further operational improvements. We are active in 122 countries and every year 2 billion users pass through one of our 51,800 installations worldwide in banks, retail outlets, healthcare institutions, and the public sector.

Qmatic has 13 subsidiaries around the world and 69 distributors are selling our solutions worldwide.

More than 30 years experience

With more than 30 years experience in the application of CFM Qmatic can support our customers through the whole process of analysing current customer flows, identifying opportunities for improvement, creating solutions and leading change management programmes in your organisation.

See our white paper on CFM for more information.



THE QMATIC SYSTEMS

A solution for every need

Qmatic today supplies solutions for financial institutions, the public sector, healthcare and retail. Though our systems look different they all work in exactly the same way; guiding customers and patients, improving customer service by prioritising and segmenting, reducing the perceived waiting time, creating a better working environment and improving work flow throughout the organisation. Our systems also measure steps in the processes and provide companies' or organisations' management with the basis for analysing and further improving customer flow processes.

We carry out all development and production ourselves to ensure full control of quality in everything we do. Our systems can be tailored for the unique requirements of every organisation and industry.



QMATIC SOLO LINEA

Flexible linear queue management system

A flexible linear queue management system, Qmatic Solo Linea, brings order and fairness to many queuing situations.

The efficiency of the service will increase with more customers served per staff member. Also better utilization of the counters and improved customer flow.

The very few settings of the Qmatic Solo Linea are easily managed with a web browser.



QMATIC SOLO

Stand-alone CFM system

An advanced easy-to-handle system for multiple categories and workstations. As a good, straightforward system Qmatic Solo is easy to use and offers statistics and management information in web format in order to organise a fair and effective customer flow. The system has a powerful, built-in processor and works as a stand-alone unit.

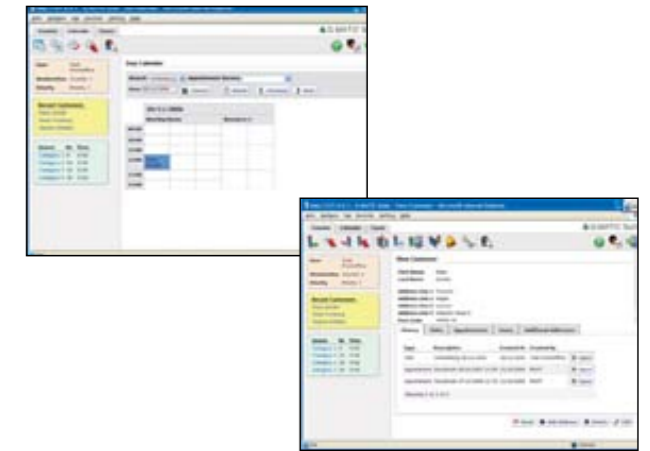

QMATIC SUITE

The solution that puts you in control of your organisation

A fully web-based, multi-branch solution covering all essential CFM functions such as customer information, a centralized database, customer history and a central calendar.



Q-WIN

Flexible and dynamic solution for customer flows

A fast and reliable PC controlled system with major flexibility in settings and configuration. Q-WIN is a dynamic software solution that truly improves the entire CFM process.

Q-WIN provides online information and stores valuable statistics to help you keep track of and optimise your daily business.



QMATIC MANAGEMENT PORTAL

The solution that provides all the information you need to know at your fingertips

A fully web-based reporting and analyzing tool that provides functions such as consolidated reporting, scheduling and email, easy benchmarking and ad-hoc reporting.

Software



Qmatic provides a wide range of modular and integrated software products especially designed to optimize your organization's customer flow and related processes. The software product range covers all essential CFM processes from core queue control like Q-WIN to MI solutions as Qmatic Management Portal and media solutions such as Qmatic Monitor.

Our product range is designed to be extremely modular and configurable. By combining and configuring different modules and applications we provide the necessary scalability and flexibility to create the most optimum customer flow solution for every situation, from small single site to large web-based enterprise solutions.

Our customer flow software record essential milestone data in every step of your customer flow process. With this valuable information we empower and inform decision makers, providing them with live situation overviews, automatic alert functions on e.g. KPI and SLA values, statistical reporting and analytical functionality to e.g. reduce waiting times and optimize staff efficiency.

Our media solutions provide the option of informing and entertaining customers in every step of your customer flow process, resulting in improved efficiency, customer experience and quality of service.

SOFTWARE



Q-WIN S (SE)

Q-WIN S (SE) is the latest version of our most used CFM software and is at the heart of most of our systems. The three main functions at the heart of Q-WIN are; controlling and holding the actual queue status, storing statistical data and controlling hardware such as ticket printers and displays. Q-WIN can be adjusted to meet any specific customer requirement due to the high configuration level and internal scripting capability .

In addition to its core functions Q-WIN is applied in several internal applications and options, which are described separately in this product catalogue. Several external applications such as Qmatic Monitor are also connected to Q-WIN by means of licensing and communication with Q-WIN.

Q-WIN is therefore an extremely modular and highly scalable product, playing a central role in configuring the most optimum customer flow solutions required.

Q-WIN can be implemented in many different environments such as stand alone, networked or a combination of these. When Q-WIN is used in a network environment, Q-WIN users are required to connect to the Q-WIN system. Alternatives for the standard Q-WIN user include API user, Q-WIN Client and Qmatic Web Terminal, which are described in this product catalogue as separate products.

Q-WIN S (SE) is also the version which works together with the TP-series printer range.

Features

- Core functions; control actual status, store management information, control hardware
- Can handle up to 100 workstations and 255 different queues
- Runs in stand-alone and/or local/wide area network configurations
- Provides live management information
- Script programming, including advanced script SQL/API commands
- SQL functionality makes it possible to connect to most types of databases
- Encrypted password protection
- User groups can be defined
- 128 bit encrypted network communication
- Embedded web server
- Integrated report function
- Vista compliant

ARTICLE NUMBER	
SW Q-WIN S	10110600
SW Q-WIN S; User /U	10110660

SOFTWARE

Q-WIN Mail

Q-WIN Mail is the Q-WIN option enabling email functionality and works with any standard email system and is easy to configure.

By configuration in Q-WIN, pre-set emails are automatically sent to any pre-defined email address based on any event or circumstance. Q-WIN Mail therefore has a very flexible functionality and can be used for many alerting and information processing purposes. For example Q-WIN Mail can be used to send email alerts to appropriate personnel when service levels peak, when a customer with an appointment arrives, when a customer for a certain service arrives, when the alarm function is used at a counter. Again, in principle an email can be generated on any Q-WIN event or circumstance.

Features

- Using flexible scripting to send email messages for different events or circumstances to any email address.
- Total SMTP mail compatibility

ARTICLE NUMBER	
SW Q-WIN S; Mail /S	10110643

Q-WIN Voice

Q-WIN Voice helps people on arrival and when being called to a service point. Q-WIN Voice adds sound to your Q-WIN system, can be customized, programmed and is compatible with every spoken language.

Q-WIN Voice gets customers attention in busy offices and can “speak” using a male or a female voice. It also integrates with displays to call customers vocally and visually and can deliver information on two separate channels.

Features

- Multiple language compatibility
- Male or female voice usage
- Customizable
- Programmable
- Works on two channels

ARTICLE NUMBER	
SW Q-WIN S; Voice /S	10110642

Q-WIN Ticketless

Q-WIN Ticketless allows you to use Q-WIN in a system without a ticket printer. Q-WIN Ticketless makes it easier to use advanced, integrated solutions. In certain service environments, a higher level of personal service and customer identification is required. Q-WIN Ticketless extends the power of Q-WIN into these environments, giving customer service managers the option of identifying and segmenting customers by name.

ARTICLE NUMBER	
SW Q-WIN S; Ticketless /S	10110647

Q-WIN Custom Layout

This option extends the functionality of management screens* and Q-WIN reports*.

The option is required when the management screens included in Q-WIN and/or reports need to be adjusted (e.g. for translations), completely new screens/reports need to be designed according to specific customer requirements or when you want to use screens/reports from previous versions of Q-WIN.

Note: This option is required for Qmatic touch screens where management screens are used as page flow systems.

*) Management screens being .sup files, report files being .srp files.

ARTICLE NUMBER	
SW Q-WIN S; Custom Layout /S	10110649

SOFTWARE

Q-WIN Distributed Management

Q-WIN Distributed Management enables the functionality to collect statistics and view live management information from several branches. In a multi branch (multi Q-WIN) environment only one of the Q-WIN systems needs to be provided with this option.

Users connected to this Q-WIN system can connect to the other branches in the branch selector list.

Note: Although Q-WIN Distributed Management is still an existing option for centralized reporting and live management views a new alternative is the Qmatic Management Portal.

ARTICLE NUMBER	
SW Q-WIN S; Distributed Management /S	10110648

Q-WIN Database Statistics

Q-WIN Database Statistics allows you to store statistics directly in the Q-WIN database. The database formats supported by Q-WIN are Microsoft Access, SQL server and Oracle. Direct storage of statistical information in a database offers the possibility of using the information in third party applications such as Microsoft Excel.

Note: Although Q-WIN Database Statistics is an existing Q-WIN option we refer to the Qmatic Management Portal when storing Q-WIN statistics in a performance optimized relational data warehouse providing web-based reports and analytical tools at the same time.

ARTICLE NUMBER	
SW Q-WIN S; Database Statistics /S	10110640

Q-WIN API

The Q-WIN API releases the power of Q-WIN to other systems. The Q-WIN API allows you to exchange commands and information between Q-WIN and other Windows programs. The Q-WIN API is programmable from almost any Windows programming language. The API Server option opens your Q-WIN for this function.

The Q-WIN API user option determines the number of users that can use the API function at the same time. Using Q-WIN API means you can control Q-WIN from custom-built, integrated consoles and communicate with Q-WIN from other systems in real time.

Features

- Covers a broad range of commands
- Integrates Q-WIN with other systems
- Simple to install and maintain

ARTICLE NUMBER	
SW Q-WIN S; API Server /S	10110645
SW Q-WIN S; API Client /U	10110667

Q-WIN Advanced Scripts

Q-WIN Advanced Scripts extend the standard scripting capability in Q-WIN with SQL and API commands.

ARTICLE NUMBER	
SW Q-WIN S; Advanced Scripts /S	10110646

SOFTWARE



Qmatic Client Terminal

The Qmatic Client Terminal allows you to serve, call and identify customers in one easy-to-use interface. The Qmatic Client Terminal has all the functions and features you need to provide good customer service at the click of a mouse. With this terminal you can do all standard CFM functions like call, recall, and transfer, create tickets, add matter codes and send alarms. It also offers the possibility of viewing customer appointments and history as well as integrated management views.

Note: Although the Qmatic Client Terminal is an existing option in Q-WIN we refer to the Qmatic Suite for a web-based modular solution providing extended functionality.

Features

- Customer appointment and history lists
- Integration with Qmatic Calendar
- Add notes to customer entries
- Customer recall
- Matter code integration

ARTICLE NUMBER	
SW Q-WIN S; Qmatic Client Terminal /U	10110661

SOFTWARE

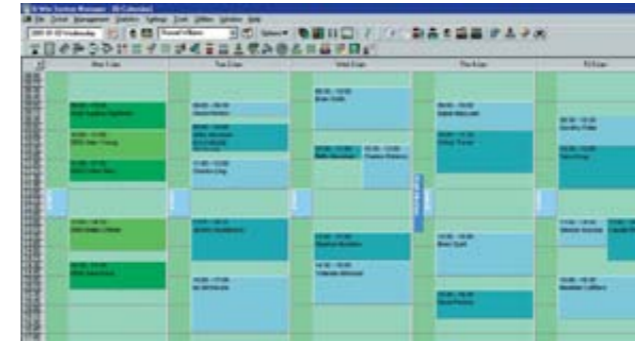

Qmatic Calendar

Appointments are an essential part of CFM benefiting both customers and their organizations. Customers can make appointments at their convenience offering them the ability to fit in the visit with their own agenda. On arrival they are called at the appointed time, significantly reducing their, and the organization's overall waiting times.

The Qmatic Calendar provides two main overviews, the first is an overview of several appointment lists per day and the second is an overview of one appointment list for several days (configurable). Different colours (configurable) in the calendar show the different statuses of appointment customers and provide easy to read day status regarding appointment customers, and it becomes clear at a glance which customers are due to arrive, have arrived and waiting, being served or already served and left.

The Qmatic Calendar can be set-up for booking appointments for specific staff members or for specific services. Appointment bookings are done on a customer basis where either a new customer can be created or an existing customer can be selected from the existing customer's base (customer database). Additional notes relating to the appointments can be added when an appointment is booked.

A valuable extra function in Qmatic Calendar is the side planner, which allows you to add extra information next to a booked appointment in a side bar.

An important added value of the Qmatic Calendar is the seamless integration with the Q-WIN software by which we not only offer an appointment schedule system but also an appointment customer handling system. Arriving appointments are identified as such at either a reception or self-service kiosk. Automatic identification is possible using electronic cards or using appointment confirmation e.g. pre printed with bar codes. After an appointment arrives Q-WIN can generate automatic alerts for the appropriate staff, also alerts can be generated when appointment times are exceeded.

Note: Qmatic Calendar is an internal application of Q-WIN and is licensed per user only.

Note: For a web-based central calendar function we refer to the Qmatic Suite Calendar

Features

- Customer appointment booking for staff or service
- Handling of customer with appointment after arrival through seamless integration with CFM system (Q-WIN)
- Automatic on arrival of customer
- Automatic alerts when appointed time is exceeded
- Side planner for additional information
- Special reception list view with search and sort functions for setting appointed customer easily
- Different colours for different appointments
- Side planner for extra information
- Quick appointment booking through customer selection

ARTICLE NUMBER	
SW Q-WIN S; Qmatic Calendar /U	10110662

SOFTWARE

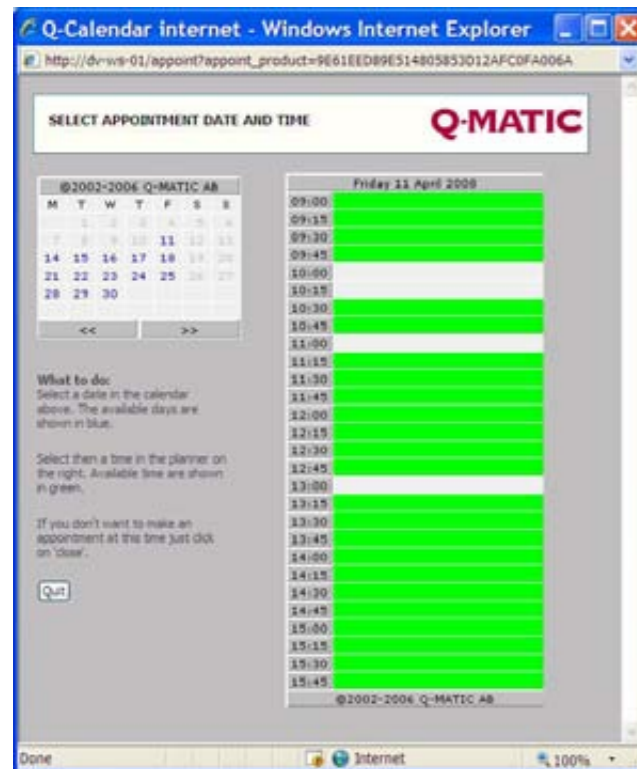

Qmatic Internet Calendar

The Qmatic Internet Calendar is an extension to the Qmatic Calendar allowing customers to book appointments via the internet 24 hours a day and provides an automatic email confirmation for each appointment made. Customers can select what service they wish to make an appointment for, on what date and choose from available appointment times to book an appointment.

Note: The Qmatic Internet Calendar requires the Qmatic Calendar for operation and is therefore not a stand alone appointment system.

ARTICLE NUMBER	
SW Q-WIN S; Qmatic Internet Calendar /S	10110666

Qmatic Staff Basic

Qmatic Staff Basic allows you to quickly and simply compare staff allocations to service targets to determine how many staff members you should have up front, and when.

Features

- Easy to use
- Break and lunch planning
- Variable service targets

ARTICLE NUMBER	
SW Q-WIN S; Qmatic Staff Basic /U	10110664

SOFTWARE

Qmatic Staff Advanced

Qmatic Staff Advanced allows you to determine the most optimum counter occupation by selecting statistics and then changing the number of open service points. Qmatic Staff Advanced recalculates and shows graphically what the influence of your actions are on waiting times. In addition Qmatic Staff Advanced offers the option of changing values in statistics such as the number of customers arriving or the average transaction time resulting in a recalculation of the waiting time.

Features

- Advanced, detailed reports
- Staff schedule templates
- Activity creation and management
- Weekly and monthly overtime controls
- Data manipulation tools

ARTICLE NUMBER	
SW Q-WIN S; Qmatic Staff Advanced /U	10110663

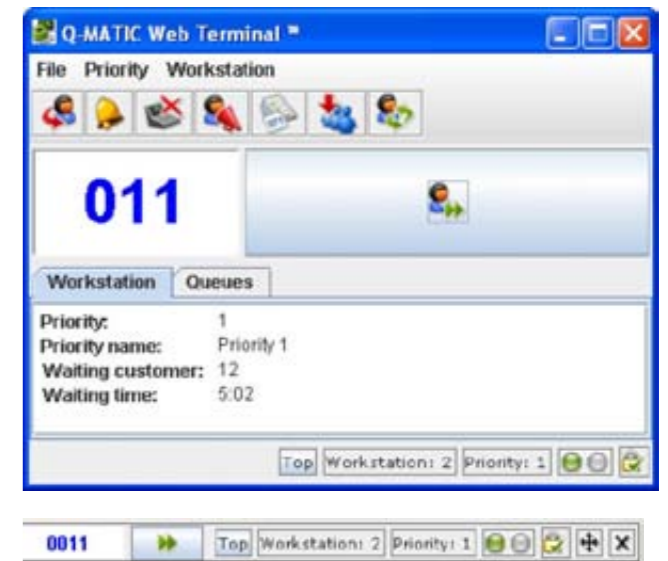

Qmatic Web Terminal

The Qmatic Web Terminal is a software counter terminal allowing you to manage the standard customer flow processes. Login, call, close, transfer, recall and related functions as well as queue status and waiting time information are all available in the clean and modern designed, easy to use Qmatic Web Terminal.

The Qmatic Web Terminal is available in a compact version that can be set to be always on top. Thanks to this feature, the user can always see the Terminal on their screen, even when other applications are running.

Several workstations can be managed inside the same terminal window in special multi terminal mode.

The Java technology makes it platform independent. The Qmatic Web Terminal is easily installed on the server; only a very simple client installation is needed. Maintenance has never been easier.

Note: The Qmatic Web Terminal is an external application of Q-WIN and is licensed per user.

Features

- Optional compact always on top window
- Multi terminal mode
- Standard CRM functions, Call, Recall, Transfer, Remove, Recycle customers, Change priority
- Print tickets
- Log on and log off
- Display a queue overview
- Displays live information; customers waiting and waiting time information
- Multi-terminal mode.

ARTICLE NUMBER	
SW Q-WIN S, Qmatic Web Terminal /U	10110665

SOFTWARE



Qmatic Monitor

The Qmatic Monitor is a digital signage solution providing a combination of showing CFM related information, combined with any other type of media such as Microsoft PowerPoint, AVI, MPEG and DVD. It gives you complete control over what your customers see in the waiting area, at the entrance and can also be used as information and an alert system for you own staff in the back office.

The Qmatic Monitor offers a flexible layout existing in four main areas, including the information window showing Q-WIN information, a presentation window showing any content, top and bottom ticker lines and a pop up screen alerting customers when a new call is placed.

The Targeted Media Distribution option makes it possible to show commercials or other information and information targeted at the specific type of waiting customers.

Note: The Qmatic Monitor is an external application to Q-WIN and therefore requires Q-WIN for licensing and information purposes.

Features

- Flexible layout of monitor view with 4 presentation windows, Q-WIN information, Presentation, Pop up window and Ticker lines
- Information window can show any Q-WIN information, numbers called, waiting times, customers waiting etc.
- Multiple formats can be shown in presentation window, (Microsoft PowerPoint, MPEG, DVD, TV etc)
- Automatic import and conversion of Microsoft PowerPoint files
- Top and bottom ticker lines with adjustable speed
- Pop up customer call window
- Instant emergency messages
- Create story boards providing scheduled changes of information, presentations and commercials
- Control of monitors from central headquarters and/or local branches
- Different monitors can be grouped for easy administration of content

Optional

- Targeted Media Distribution – with this option you can target information, presentations and commercials at the audience waiting to be served
- Qmatic Monitor TV enables the showing of TV programs in the Qmatic Monitor information frame. A TV Card (e.g. Hauppauge) needs to be available in the Qmatic Monitor Player

ARTICLE NUMBER	
SW S,Qmatic Monitor 3 LIC. /S	10110672C
SW S,Qmatic Monitor 3 PLAYER /U	10110673C
SW S,Qmatic Monitor 3 TARGET MEDIA /S	10110674C
SW S,Qmatic Monitor 3 TELEVISION /S	10110675C

SOFTWARE

Qmatic Management Portal

Our CFM solutions record essential milestone data for every transaction performed within the system. This data only becomes information when it is presented in an understandable manner. The Qmatic Management Portal is the right tool to transform this data into true information and therefore gets a true 360° view of a customer-facing activities.

The Qmatic Management Portal is a complete, web-based solution mainly for handling CFM data but also offers possibilities for including other external third party data. The technical design of the portal is especially suited for central reporting.

The statistical data from the Qmatic systems is automatically imported into a central database where the data is matched, optimized and indexed. Statistical reporting and analyzing can be done on every client PC. Local installation of software is not necessary, only a browser and user access rights to the management portal have to be available.

The two available statistical user modules are Qmatic Report and Qmatic Analysis. The report module includes several standard reports which can be scheduled and automatically distributed by email or Intranet. The analyzing module allows the option of working interactively with your data, based on OLAP technology.

In addition to the reporting modules, the Dashboard module provides the ability to view live information for all connected branches.

Features

- 100% web-based clients
- Centralized reporting in multi-branch situations
- Automatic scheduled import of statistical data from all branches
- Handling and correcting of setting differences between branches
- Handling and correcting settings changes in branches
- Access rights on applications, reports and branches
- Supports UNICODE
- Supports Qmatic systems; Q-WIN Q, S (SE) and Qmatic Solo
- Supports SQL and Oracle databases
- Supports Microsoft Internet Explorer and Mozilla Firefox browsers
- Supports main Microsoft Windows operating systems

For more detailed information we refer to the Orchestra data sheet on our Partner portal.



Qmatic Report

The Qmatic Report focuses mainly on automatic executive, overview and other standard reporting. Therefore the necessary save, schedule and email functionality is implemented. Standard reports are included in the application but customized reports can be easily designed.

Features

- Able to copy report setting
- Saving report settings to be used later
- Export to Microsoft Excel and PDF
- Automatic reporting using schedule and email functionality, with selection of output format (PDF, XLS, CSV)

SOFTWARE

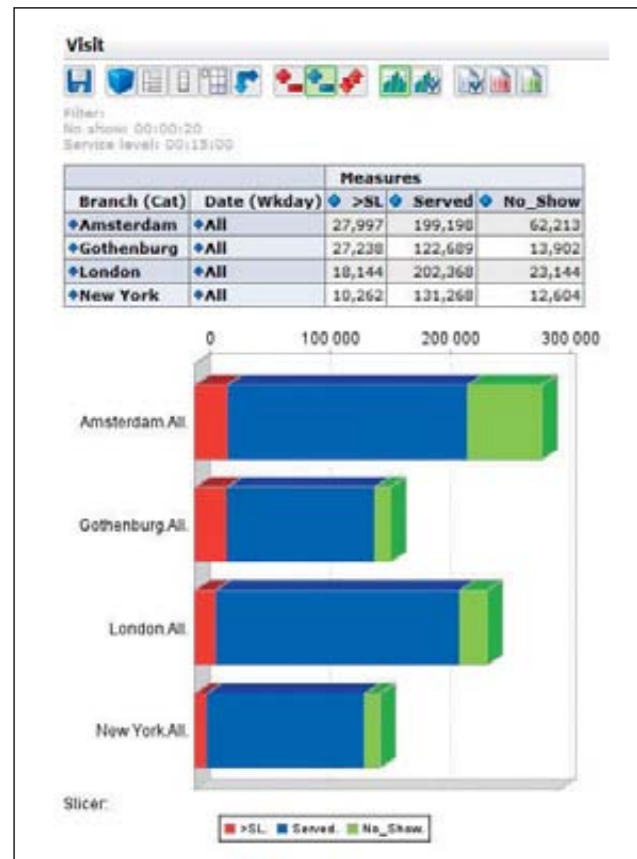

Qmatic Analysis

The Qmatic Analysis has been developed to focus on interactively working with your CFM data, based on OLAP functions as select, drill down, sorting and moving. This makes Qmatic Analysis a very powerful tool to perform e.g. trend, performance (KPI, SLA), resource optimization, ad-hoc reporting and benchmark analysis.

- Interactively view your statistical data using drill down, sort (A–Z, 1–1000) and move functions
- Flexible use of statistical data
- Create reports views yourself
- Saving analyzed views for reuse
- Export to Excel and PDF format
- Different graph options for easier analyzing

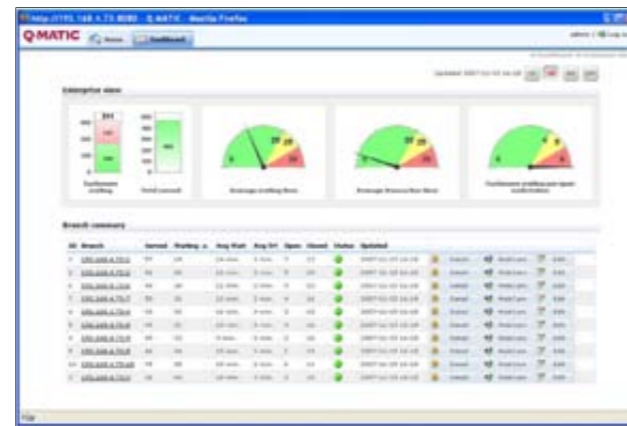

Qmatic Dashboard

The Dashboard is especially designed to show live information from multiple branches and provides the option of viewing individual branch details with one mouse click.

The Dashboard shows the main overall measures graphically, such as the number of customers waiting and how many of them have been waiting longer than the defined waiting time service level and the number of customers waiting per open counter. In the individual branch rows it shows per branch measures such as customers served, number of open counters and if the branch is connected or not.

When clicked into branch details the dashboard shows similar measures, but broken down into individual queues.

Features

- Fixed Dashboard showing live information
- Overview of all branches for most important measures
- Sort function on all parameters, to sort on e.g. longest waiting time or branch name
- Break down in branches
- Web-cam integration

ARTICLE NUMBER	
SW MGMT Portal 2.1 Report	10110400
SW MGMT Portal 2.1 Analysis	10110401
SW MGMT Portal 2.1 User	10110402
SW MGMT Portal 2.1 Branch	10110403
SW MGMT Portal 2.1 Dashboard	10110404

SOFTWARE

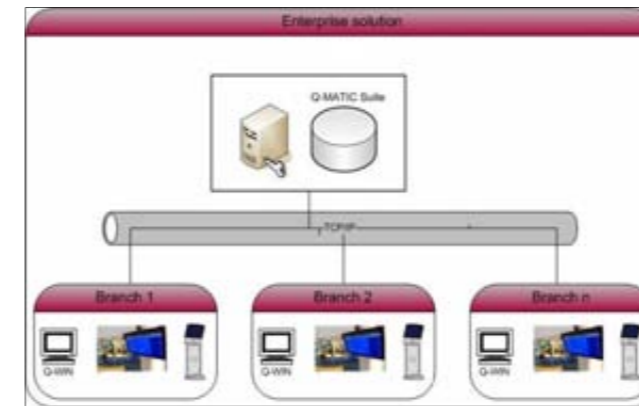

Qmatic Suite

Qmatic Suite is a highly flexible web-based application platform designed for single branch up to multi branch enterprise solutions.

Qmatic Suite exists in several seamless integrated modules and user roles such as counter, reception, appointment booking and customer history, offering the option of configuring specific CFM solutions.

Qmatic Suite provides several built in management information views showing the current status of the operation. These views are used to keep an overview of the current waiting status and staffing situation at all times. Based on this information, managers can proactively make informed decisions on staffing and planning.

The integrated workflow modules allow the automation of actions based on events or specific circumstances. Through the workflow module e.g. emails can be sent or staff can be alerted when service levels are exceeded.

With the Qmatic Suite solution all data is collected and archived in a central relational database supporting Microsoft SQL and Oracle.

Note: Qmatic Suite is fully compatible with Q-WIN for essential functions such as hardware control and holding queue statuses.

Note: For statistical management information we refer to the Qmatic Management Portal.

Features

- Web-based technology, no installation on client pc's resulting in lower total cost of ownership, TCO
- Enterprise solution, control from one to many CFM systems
- Support for Q-WIN Q and Q-WIN S SE
- Central administration for customer, staff members, permissions and several other important settings
- A customer history module
- Adding information to customer visits, enquiry and outcome types, notes, wrap up time registration
- Alert functions

- Calendar module
- Live management views
- Questionnaire module
- Supports UNICODE
- Supports server operating systems Windows XP, Vista, 2000 Server, 2003 Server
- Supports databases Microsoft SQL Server 2000, Microsoft SQL Server 2005 (including the Express edition), Oracle 9i, Oracle 10g (including the Express version)

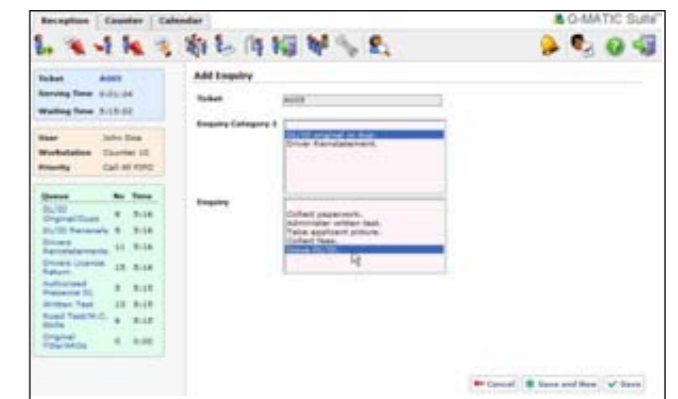

Qmatic Suite Counter

Naturally, standard functions such as Login, Call, Transfer, Close etc. are available in the Qmatic Suite Counter, but also additional new functions are available such as adding notes to customer visits (both free format and pre defined notes), add enquiry type to customer visits (enquiry types can be defined in several levels), add outcome of visits, (e.g. "successful transaction", or reason why transaction was not successful), wrap up time registration (the reason time is spend on transaction when customer left).

Before calling customers, the counter users have the relevant waiting times, number of customers waiting and also customer history instantly available on their screen, making the transaction times quicker and the service more efficient. Since the system is highly flexible it enables the user to select each queue to see relevant waiting times, number of customers waiting for each specific service, calculated waiting times, and transaction times.

SOFTWARE

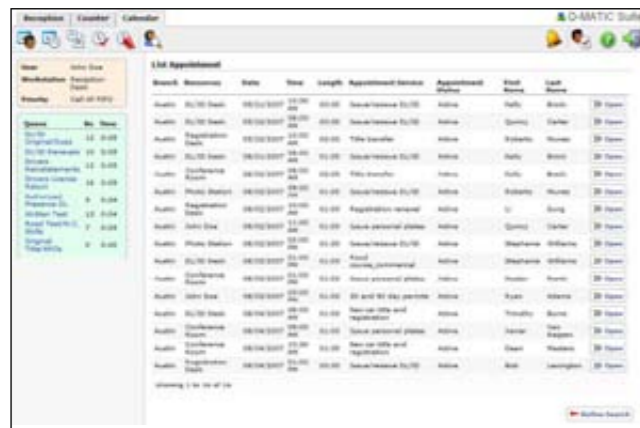
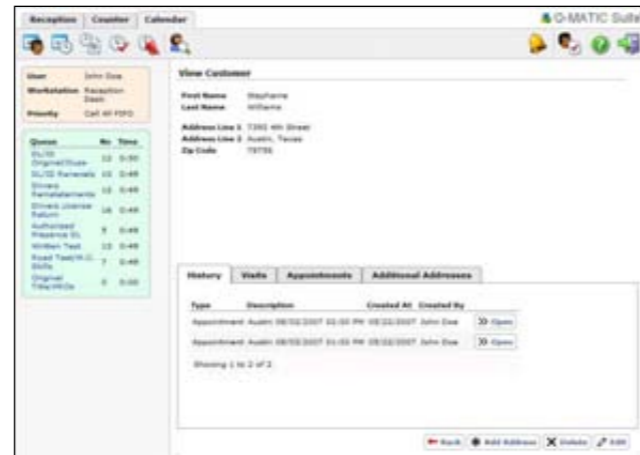
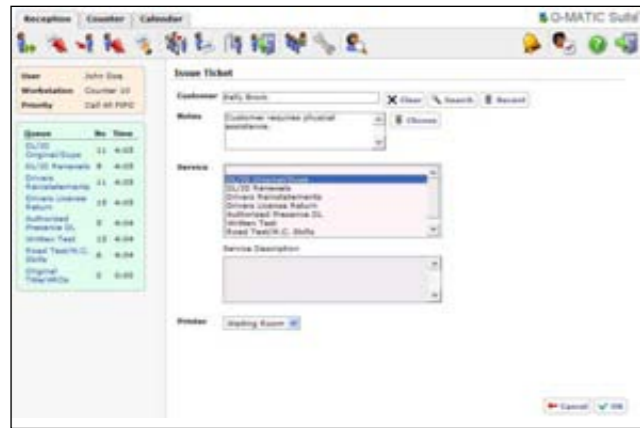

Qmatic Suite Customer History

Customer History is an additional module to Qmatic Suite, offering the option of recording visits on customer basis. All customer-related visit and appointment information is stored centrally and offers a very valuable source of information for customers organizations. Customer history information is available for all Qmatic Suite roles (e.g. Counter, Reception and Calendar).

Customers never have to repeat themselves when they see different advisors as the customer history can be called up at any service point.

Qmatic Suite Reception

The receptionist can provide customers with a ticket automatically adding them to the appropriate queue, or directing them to a relevant advisor. The receptionist can also see the number of customers waiting at all times, whilst having immediate access to the customer history.

Qmatic Suite Floorwalker

The floorwalker role is a specially designed 'meet and greet' role used together with handheld (tablet) wireless units. The floorwalker can meet customers at the door, log visitors and/or issue tickets and add the customers to the correct queue. A silent alarm function can be added to enable the user to alert colleagues if necessary.

SOFTWARE

Qmatic Suite Calendar

Appointments are an essential part of CFM benefiting both customers and their organizations. Customers can make appointments at their convenience offering them the ability to fit in the visit with their own agenda. On arrival they are called at the appointed time, significantly reducing their, and the organization's overall waiting times.

The Qmatic Suite Calendar offers extended functionality compared to the Qmatic Calendar modules. The Qmatic Suite Calendar is a complete web-based solution and due to its flexibility and scalability it can be used on a small scale with only a few users; or throughout a network of branches with hundreds of users. The appointment planner enables staff to book and view appointments for different people, branches or services. Users can easily see the number of available slots per day, week or month, for each branch in a network.

Qmatic Suite Calendar provides several overviews such as daily and monthly views where different colours (configurable) show the different statuses of appointed customers and the free time slot indication, providing quick appointment booking.

Qmatic Suite Calendar can be set-up for different appointment scenarios such as customer to staff, customer to service bookings and also provide the opportunity of booking additional resources. When an appointment is booked either a new customer can be created or an existing customer can be selected from the existing customer's base (customer database). Additional notes relating to the appointments can be added when an appointment is booked.

An important added value of the Qmatic Suite Calendar is the seamless integration with the total CFM solution by which we not only offer an appointment schedule system but also an appointment customer handling system. Arriving appointments are identified as such at either a reception or self service kiosk. Automatic identification is possible using electronic cards or using appointment confirmations e.g. pre printed with bar codes. After an appointment arrives Q-WIN can generate automatic alerts for the appropriate staff, also alerts can be generated when appointment times are exceeded.

Note: The Qmatic Suite Calendar can also be used as a stand-alone appointment booking system.

Qmatic Suite Call Centre User

By using this function, call centre agents can make bookings directly with real time access to availability. Users can limit the parameters accessible to call centre agents for appointment bookings, such as time period, resources and services.

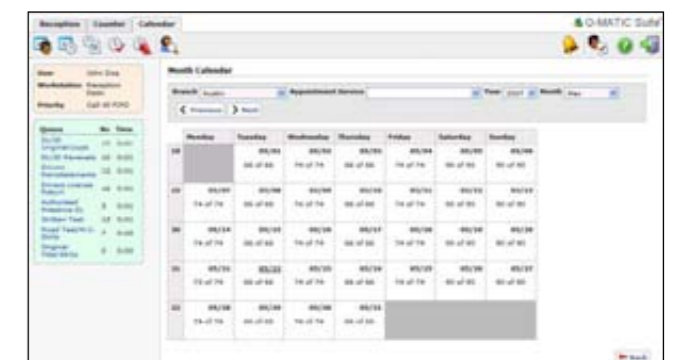
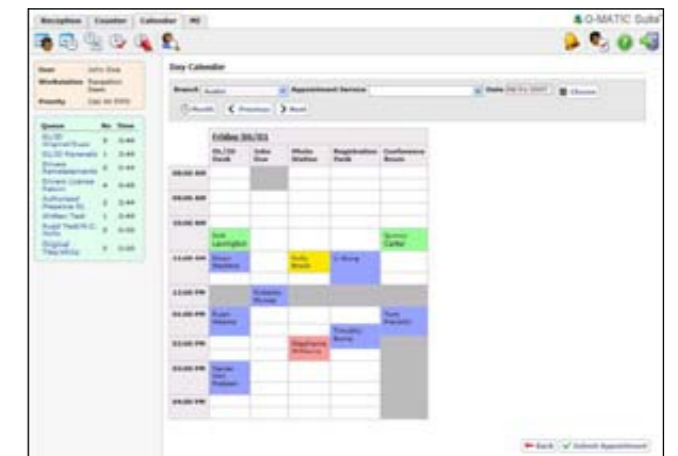

SOFTWARE

Qmatic Suite Web Service Module

The Web Service module offers the ability to integrate with 3rd party applications. Reception, Counter, Management information and Calendar functions are all supported.

For example the web service package allows the creation of an internet appointment booking facility within Qmatic Suite Calendar.

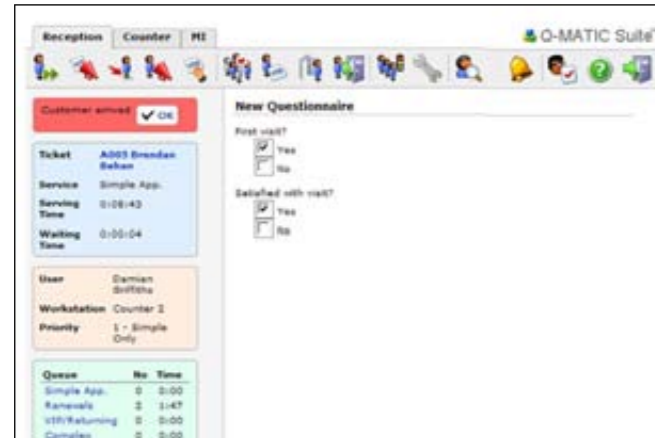

Qmatic Suite Questionnaire

The Questionnaire module allows staff members to ask questions of customers being served at their desk and store the answers.

The questionnaire module allows different formats for the answers – including; free text in single or multiple lines, single choices from list or radio buttons and multiple choices from lists and check boxes. A questionnaire can be created and edited by an administrator defining questions and answer types.

The outcome of a questionnaire is stored related to the customer's details and can therefore be reviewed through the customer history module.

The Questionnaire module is licensed as a module only, for access to the module Qmatic Suite Counter users are required though.

Important to understand is the Questionnaire module does not contain standard packages for customer enquiries or customer feedback systems in situations where the customer themselves define answers on a touch screen or similar device.

Qmatic Suite LDAP Module

The Qmatic Suite LDAP Module is necessary for integration with LDAP servers – like Microsoft Active Directory – to allow simple user management from a single location (single sign on).

Qmatic Suite Development KIT

Qmatic delivers the Qmatic Suite for standard operation covering most CFM situations. With the included Qmatic Suite Development KIT it is possible to create additional functions in the Qmatic Suite in order to customize the solution to specific customer needs. Several examples are distributed through your Partner Portal.

Note: The separately described Reception and Floorwalker both require a counter user for operation.

ARTICLE NUMBER	
SW Suite 2.1 Base License	10110710
SW Suite 2.1 Branch License	10110711
SW Suite 2.1 Counter User	10110712
SW Suite 2.1 Cust. History Module	10110715
SW Suite 2.1 Calendar Module	10110716
SW Suite 2.1 Calendar User	10110717
SW Suite 2.1 Call Center User	10110718
SW Suite 2.1 LDAP Module	10110721
SW Suite 2.1 Web Service Module 1	10110723
SW Suite 2.1 Questionnaire Module	10110724

SOFTWARE



Qmatic Digital Signage

Digital signage is all about getting your message across where it counts – while you have the customer's full attention. With queuing information visible on media screens there is a compelling reason for customers to keep looking so eye-time there is more valuable than posters, normal digital signage screens or even television or cinema advertising.

Following-on from the principles of the core product; Orchestra Digital Signage supports enterprise-wide communication with customers. Messages can be managed centrally but delivered locally. Media is distributed on the same WAN connection as the system uses to manage the customer flow. The system allows you to create digital signage screens that combine the queuing information, essential to getting the audience's attention, with the messages.

The statistics generated by the Qmatic system show the number of customers in the branch at any given time and what services they waited for meaning that you can target messages much more effectively. Upselling and cross-selling are just two applications of the Digital Signage solution.

SOFTWARE

Qmatic Orchestra

Orchestra is the centralised enterprise-scale CFM solution from Qmatic designed for larger organisations. It has been developed for ultimate ease of maintenance, maximum reliability and low cost. The way it does this is by centralising the core software, keeping all administration, software maintenance and data storage in the safe, secure and easily accessible surroundings of the administrative centre of the organisation.

It is designed for organisations that span many branches as well as for larger scale single sites where many separate customer flow situations need to be managed as one. In all cases Orchestra operates according to the same principle – multiple autonomous operations working with one highly configurable, scalable and future-proof CFM solution.

Orchestra consists of the central software core running on one or multiple servers all placed at the administrative centre of the organisation. This software handles all CFM situations across all branches. The equipment needed to manage the customer flow in each branch connects back to this central software via a wide-area network connection.

Creating successful enterprise-scale solutions requires much more than the linking together of discrete branches however. Orchestra understands that branches or departments will vary in detail but need to be grouped to make configuration and interpretation of statistics as easy and logical as possible. Orchestra therefore satisfies this need with advanced configuration management that allows branches to be grouped and managed together.

Orchestra can provide advanced statistical analysis of data. As it is an enterprise-scale system, managers have access to answer questions right across the organisation: Which are the most effective branches? Which are the teams most in need of support? Comparisons can be drawn across the whole organisation. Analysis of data includes both historical and real-time information together allowing managers to ask: How does what we are seeing now compare with history? The core capabilities of Orchestra are accompanied by a number of sophisticated options such as *Matchmaker* and *Digital Signage*.

ARTICLE NUMBER	
SW Orchestra Capacity Licence	10115001
SW Orchestra User License	10115000
SW Orchestra Dashboard	10115010
SW Orchestra Analysis	10115014
SW Orchestra Digital Signage	10115015
SW Orchestra Matchmaker	10115011
SW Orchestra Workstation Connector	10115018
SW Orchestra Reception Connector	10115017
SW Orchestra Digital Signage Connector	10115019
SW Orchestra Touch Screen Connector	10115016



Qmatic Branch Hub

With the Branch Hub, you can safely manage all the communication needs between the Qmatic equipment at a branch and the Qmatic Orchestra central server.

Branch Hubs are placed in local branches and communicate with the central server and all the Qmatic hardware at the local site, for example, printers and displays. A Branch Hub isolates the Qmatic equipment on a LAN kept separate from the client's WAN with the help of a firewall.

For any Qmatic hardware not connected by IP, you will always need a Branch Hub.

ARTICLE NUMBER	
Qmatic Branch Hub	10214150
Interface RS232-1745	10112080

SOFTWARE

Reports

Orchestra comes with a set of the most used CFM reports as standard. This covers most of the reporting needs, including functionality as automatic reporting sent by email to designated staff. The user can group the branches to see, for example, every branch in a street, a city or a region.

Additional reports can be created on request.

Analysis

The Analysis tool allows you to view your important historical CFM data interactively.

The layout and the metrics you see on a report page are fixed. In Analysis you can select the metrics and data you want to see, compare and move around to create a view of your data the way you need them and want them – and save that view.

Dashboard

The Dashboard shows live information from multiple branches. It provides the option of viewing individual branch details with one mouse click.

It also shows the main overall measures graphically, such as the number of customers waiting, how many of them have been waiting longer than the defined waiting time service level and the number of customers waiting per open counter.

Workstations (reception, counter)

Workstation terminals are used to call the next customer, and to show the current queue number, number of customers waiting or the actual waiting time. They can also be used to redirect customers to other tellers, to choose and prioritise various service categories, and to send and receive messages.

Matchmaker

Matchmaker greatly increases your success rate in selling or delivering services while improving the customer's perception of your organisation and the services it provides. It does this by putting the customer at the centre of your tactical operations while maintaining operational efficiency. Matchmaker works on knowledge that is programmed into the system, describing the capabilities of each staff member. It uses this knowledge to match the staff member chosen with the customer's needs.

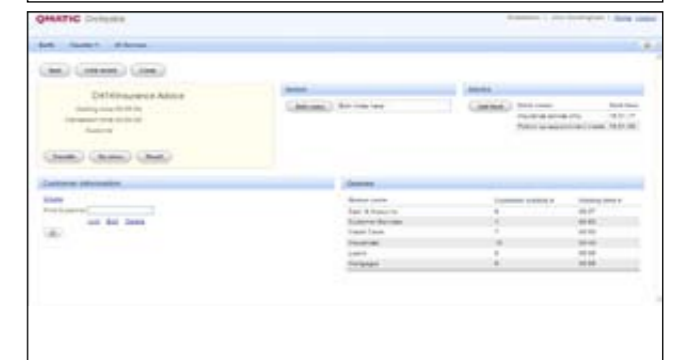
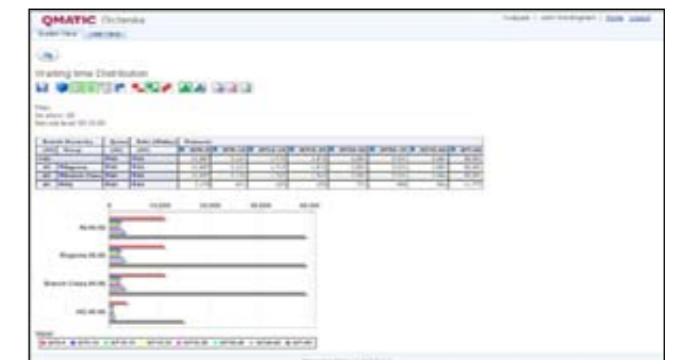

SOFTWARE

Connectors

Connectors are the professional and industry practice to integrate an enterprise product like Orchestra with other CFM systems the client may have.

Licensing

We license the number of positions used in a system, not staff. You only pay for the number of users who will use the system at any given moment – not the total number who will ever use it.

This means that if you license 100 users, it can be any 100 users as long as you do not have more than that number on-line simultaneously.

What's more, we do not discriminate between ordinary staff and senior positions like supervisors, administrators and managers – we charge the same for all staff.

What you need to run Orchestra

Orchestra works with all our hardware like the displays, touch screens, terminals and printers.

Database compatibility – Oracle and SQL server

Browser: Internet Explorer 8 or Mozilla Firefox 3.x

Other requirements: Windows Server 2003 and 2008

For more detailed information we refer to the Orchestra data sheet on our Partner portal.

TICKET PRINTERS



Ticket printers

Pedestals, stands and brackets

Tickets and card readers

The most fundamental function of a customer flow system is to provide a customer with a queue number.

Qmatic's ticket printers are well designed, easy to use and they print tickets with variable layout. It might contain for example a welcome message, a logo, information about waiting times or an advertising message. Depending on what service category the customer chooses he is given a queue number in the right queue. Using our products and systems it is possible to identify and process customers for more effective, quicker customer flows.

Using our pedestals and wall brackets it is possible to locate ticket printers where it is easy for customers to find them.

Self-service products, such as card readers and touchscreens can be used to make it easier for customers to choose the right service or to prioritise certain customers in certain service categories.

TICKET PRINTERS

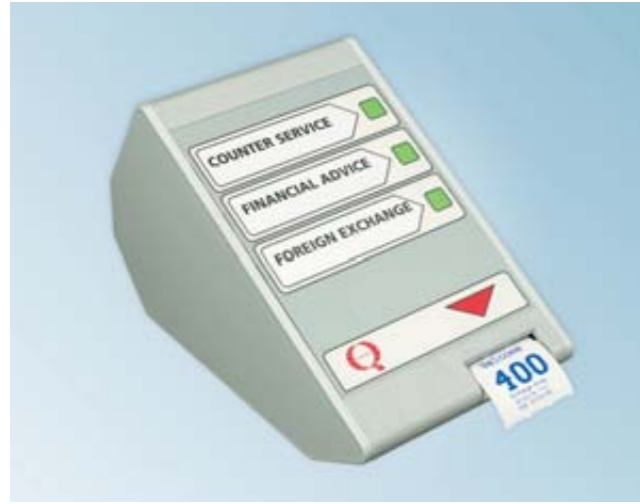

Qmatic BP2884

Qmatic BP2884 is a reliable, silent printer for ticket dispensing and can be connected to Q-WIN systems. With the Qmatic BP2884 you can print tickets with different messages and logos, waiting time information and inform customers about the services available.

Features

- Thermal print head
- 1-10 ticket buttons
- Lockable hood

ARTICLE NUMBER	
Qmatic BP 2884-62 Slave 256 KB 230 V	10202821
Qmatic BP 2884-62 Slave Buzz 230 V	10202821A
Qmatic BP 2884-62 Ext. Button 230 V	10202821B
Qmatic BP 2884-62 Slave 256 KB 115 V	10202822
Qmatic BP 2884-62 Ext. Button 115 V 1	0202822B



Qmatic TP3110

The Qmatic TP3110 is a network ticket printer for Q-WIN and the Qmatic Solo systems. The printer has large tactile buttons making it easy for visitors to select a service. With Qmatic TP 3110 you can print tickets in any language.

Features

- Ethernet connection
- Thermal print head
- 0–5 ticket buttons
- Supports all Windows fonts
- Tactile buttons

ARTICLE NUMBER	
Qmatic TP 3110	10213031

TICKET PRINTERS



Qmatic TP3115

The Qmatic TP3115 is a network printer for Q-WIN and Qmatic Solo systems. The printer has a 7-inch colour LCD touchscreen and a built-in web browser that makes it possible to display HTML pages. These pages can be used as ticket buttons as well as presenting information and communicating with the visitor. Qmatic TP3115 can print tickets and display information in any language.

Features

- Ethernet connection
- Thermal print head
- Flexible number of ticket buttons
- Support all Windows fonts
- 7-inch colour LCD touchscreen

ARTICLE NUMBER	
Qmatic TP 3115	10213041



Qmatic TP 3150/TP 3155

The servers in a Qmatic Solo system are the Qmatic TP3150 or Qmatic TP 3155 ticket printers. The Qmatic TP3150 is a ticket printer with tactile ticket buttons. The Qmatic TP3155 is a ticket printer with a 7-inch colour LCD touchscreen and a built-in web browser. Both printers have a built-in web server that gives the user access to all information from any PC with a web browser.

Features

- Stand-alone system (no PC server)
- Built-in web server
- Ethernet connection
- Web-based workstation terminal is included
- Built in web browser (TP3155)
- 7-inch colour LCD touchscreen (TP3155)
- Supports all languages
- Five reports in PDF format
- On-line information on one management screen

ARTICLE NUMBER	
Qmatic TP 3150	10213051
Qmatic TP 3155	10213061

TICKET PRINTERS

Accessories Qmatic BP 28 series

A Front panels

Front panels are available with 1–10 and 16 ticket buttons.

B Interface external keyboard matrix

The keyboard matrix makes it easy to connect external tickets to a BP 28 series ticket printer. Note that the ticket printer must be prepared for external ticket buttons.

Accessories Qmatic TP 31 series

C Button plate

Required when you want to increase the number of buttons when less than five buttons have been used.

D Cushion pad

Required when you want to increase the number of buttons, when less than five buttons have been used.

E Button cover

Cover the hole when a ticket button is removed.

F Label cover

The transparent cover for the labels.

G Labels

The paper label indicating the service. A4 or letter.

H Signboard

Used together with the floor pedestal to have a signboard above the ticket printer.

I Magnetic Card Reader Swipe TP31xx

The Card Reader Swipe TP31xx is an accessory for the Qmatic TP31xx series printers. Mounting the card reader on a printer is easy, everything needed is included. With the card reader it is possible to use magnetic cards for the identification of customers.

ARTICLE NUMBER	
Qmatic BP 28 series Front panels	122001XX
Qmatic BP 28 series Interface ext keyboard matrix	10117002
Qmatic TP 31 series Button plate	14110409E
Qmatic TP 31 series Cushion pad	14110411F
Qmatic TP 31 series Button cover	14110403C
Qmatic TP 31 series Label cover	14110402C
Qmatic TP 31 series Labels A4	14110055A
Qmatic TP 31 series Labels Letter	14110056A
Signboard to pedestal	10930401
Magnetic Card Reader Swipe TP31xx	11340110



TICKET PRINTERS



Accessories Qmatic Vision

A Floor pedestal

When the Qmatic Vision is placed on the floor.

B Table/wall stand

When the Qmatic Vision is placed on a table or a wall.

C Signboard, frosted glass

A frosted glass plate for the floor pedestal.

D Signboard, glass

A clear glass plate for the floor pedestal.

E Card reader kit

The card reader can be used together with both the floor pedestal and the table/wall stand.

F Camera kit

The camera is usually used together with the floor pedestal.

G Ceiling connection kit

This is used together with the floor pedestal when the power is coming from the ceiling.

H Lighting kit

The Lighting kit is an accessory for a Qmatic Vision. It is a thin tube with LEDs that sits on top of the Signboard on the pedestal. The lighting makes an engraved sign on the signboard glow. The kit comes complete with cable and connector ready to install.

ARTICLE NUMBER	
Qmatic Vision Floor pedestal	10214251
Qmatic Vision Table/wall stand	10214201
Qmatic Vision Signboard, frosted glass	14107323
Qmatic Vision Signboard, glass	14107321
Qmatic Card Reader Kit Vision ISO12+JIS	10214190
Qmatic Card Reader Kit Vision ISO 123	10214191
Qmatic Vision Camera kit	10214195
Qmatic Vision Ceiling connection kit	10214301
Lighting kit with led lights and cables	10214180
Blank clear plastic panel for lighting kit	14107325

Qmatic Vision

Qmatic Vision is a customer service point for Q-WIN systems. It can be used to communicate with visitors to improve both the service level and effectiveness. The included ticket printer is a network printer that can print tickets in any language.

Qmatic Vision has a built-in web browser and can show all kinds of information. A card reader can be added to identify visitors. It is also possible to add a web camera to improve the identification. Qmatic Vision can be placed on a floor pedestal, on a table or on a wall.

Features

- Ethernet connection
- Built-in web browser
- Loudspeakers are included
- Supports all languages
- 17-inch colour LCD touchscreen
- Various stands for wall, desk and floor mounting
- Floor pedestal with a large glass signboard where it is possible to have a logotype, text, etc.
- Optional magnetic card reader for identification
- Optional web camera for better customer identification

ARTICLE NUMBER	
Qmatic Printer Vision 17" EU/US	10214105

PEDESTALS, STANDS AND BRACKETS



Qmatic P2201 Aluminium

Qmatic P2201 is made of light aluminium plates and can be folded for economical transport. It is an economical alternative to more expensive pedestal solutions. A tube for the power cable can be attached to the back of the pedestal when power is supplied from the ceiling. Using the pedestal means you can place the ticket printer where it is easy for customers to find.

Features

- Light and easy to transport
- Can be folded

ARTICLE NUMBER

Qmatic P 2201 Aluminium Silver	14103008
--------------------------------	----------

PEDESTALS, STANDS AND BRACKETS



Qmatic P2202 Iron

The pedestal is made of steel plates for use in exposed environments. The ticket printer is placed inside the pedestal. Using the pedestal means you can place the ticket printer where it is easy for customers to find.

Features

- Designed for exposed environments
- Available in any choice of colour (RAL)

ARTICLE NUMBER

Qmatic P 2202 Iron Gray (RAL 9018)	14103013
Qmatic P 2202 Iron Any colour	14103018
Qmatic P 2202 Iron Stainless steel	14103019



Qmatic P2204 Tube Stand

The pedestal is a steel tubular construction that can be easily dismantled for transportation. A top extension can be added. Using a pedestal means you can place the ticket printer where it is easy for customers to find.

Features

- Easy to dismantle and transport
- Possible to add a top extension

ARTICLE NUMBER

Qmatic P 2204 Tube stand with top extension	14103015
Qmatic P 2204 Tube stand without top extension	14103016

PEDESTALS, STANDS AND BRACKETS



Qmatic Shelf for BP28 series

This is a shelf designed for the BP2884 and BP2882 ticket printers. The shelf can be attached to any firm surface, for example walls, pillars, etc. Using the shelf means you can place the ticket printer where it is easy for customers to find.

Features

- Designed for the BP28 series ticket printers
- Quickly and easily fasten to both wall and printer

ARTICLE NUMBER	
Qmatic Shelf for BP 28 series	14103007



Qmatic Table Stand TP31xx/Nova

The table stand is one of three options for mounting Qmatic TP31 series printers. Use the table stand to place the printer on a table or other horizontal surface. Use the fastening bracket with screws or double-sided tape to fix the ticket printer to the surface.

ARTICLE NUMBER	
Qmatic Table Stand TP31xx/Nova	10213204



Qmatic Wall Bracket TP31xx/Nova

The Wall bracket is one of three options for mounting a Qmatic TP31 series printer. Use the wall bracket to mount a printer on a wall or other vertical surface.

ARTICLE NUMBER	
Qmatic Wall Bracket TP31xx/Nova	10213205



Qmatic Floor Pedestal P3310

The floor pedestal is one of three options of mounting a Qmatic TP 31 series printer. Use a floor pedestal to place a printer on the floor. Cables can be routed from the floor or, with upper columns, from the ceiling. The power supply can be placed inside the foot. Use a signboard on an upper column to direct the visitors to the ticket printer. Pedestal weights can be placed inside the foot when fixing the foot to the floor is not feasible.

ARTICLE NUMBER	
Qmatic Floor Pedestal P3310	10213206
Column upper 1500 mm TP31xx	10213202
Column upper 3000 mm TP31xx	10213203
Weights for floor pedestal P3310	10211029



Qmatic Floor Pedestal P3311

The P3311 is a pedestal for a Qmatic TP31xx printer.

- The pedestal can be mounted standing straight up or leaning 5°.
- There is an extension available to lengthen the pedestal.
- Cables can be routed from the floor or, with a tube, from the ceiling.
- Use a sign on a signboard on the tube to direct visitors to the printer, or put the sign on the extension.

ARTICLE NUMBER	
Qmatic Floor Pedestal P3311	10213210



Qmatic Extension Pedestal P3311

The extension is an accessory for the P3311. It lengthens the pedestal 60 cm. The same bracket for attaching a tube on top of the P3311 is also used for the extension.

ARTICLE NUMBER	
Qmatic Extension Pedestal P3311	10213220

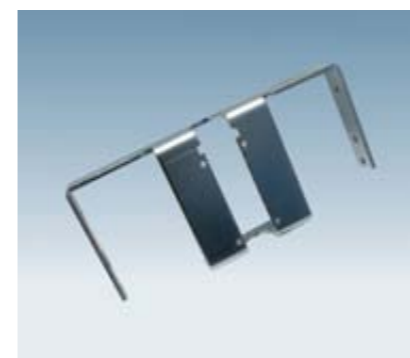

Qmatic Tube Bracket Pedestal P3311

The tube bracket is an accessory for the P3311. Use it to attach a tube on top of the pedestal or the extension. It is now possible to route cables from above down to the printer in a neat way. The tube can also be used for a signboard or a display.

ARTICLE NUMBER	
Qmatic Tube Bracket Pedestal P3311	10213230

TICKETS

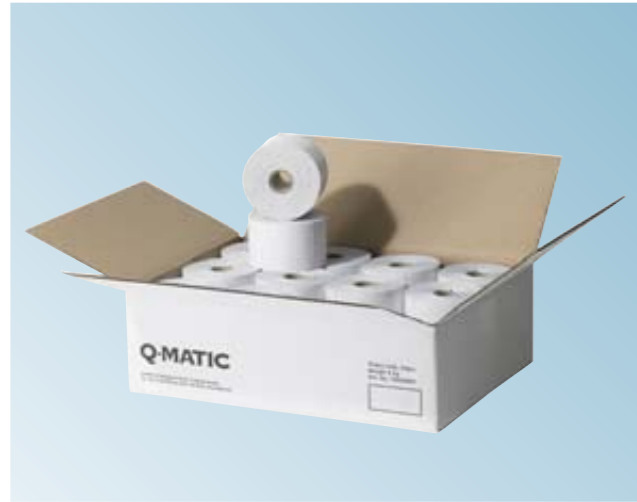

Qmatic Tickets

Qmatic Tickets are made from thermo paper to achieve a fast, superior print. The quality of thermo paper, used in the Qmatic printers, is specifically developed and manufactured for Qmatic. The right paper quality and correct heat release at the right temperature are important factors for quality printing and a long lasting print head. Using thermo paper, other than supplied by Qmatic, may jeopardize the proper function of the ticket printers.

ARTICLE NUMBER	
Qmatic Nova;	
Ticket roll black Q-Nova 100m	10900080
Ticket roll black BPFREE HS Q-Nova 100m	10900090
Qmatic BP 28 series;	
Ticket roll blue 72 g, 62 mm, 3000 tickets	10900013
Ticket roll blue 58 g, 62 mm, 4200 tickets	10900015
Ticket roll black 58 g, 62 mm, 3000 tickets	10900023
Ticket roll black 58 g, 3000, no logo	10900023A
Ticket roll black BPFREE 55 g, 62 mm, 3K PCS	10900033
Qmatic TP 31xx and Vision;	
Ticket roll black HS TP31, 2000 tick	10900085
Ticket roll black HS TP31xx w/o logo 2000	10900085A
Ticket roll blue TP31xx, 2000 tick	10900084
Ticket roll blue TP31xx w/o logo 2000	10900084A
Ticket roll black BPFREE HS TP31XX, 2K PCS	10900095

CARD READERS

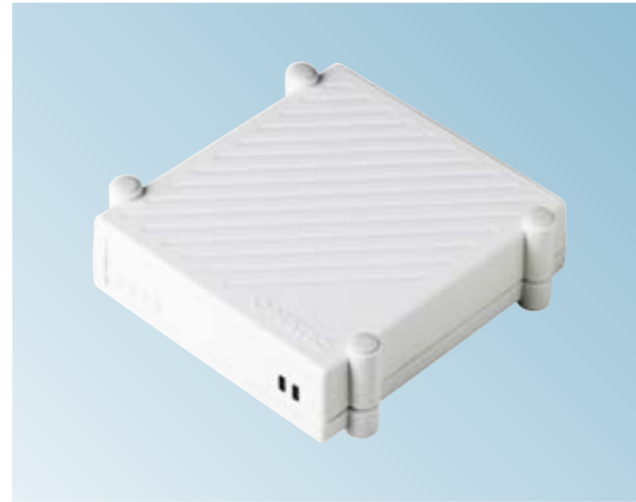

Interface Card Reader Qmatic CI 2477

The card reader interface CI 2477 makes it possible to connect card readers to a Q-WIN or a Qmatic Solo system. The information received from the card can be used to find a customer in the Q-WIN database. In Qmatic Solo the validation of a card can be identified. Using the card reader interface means you can identify customers, carry out a security check, print tickets with the customer's name, check if the customer has booked an appointment and document a customer's history.

Features

- Swipe readers ISO track 1, 2 or 3
- Swipe readers JIS II
- Motor driven ISO readers track 1, 2 and 3 (OMRON 3S4YR-MCR)
- Motor driven JIS II readers (OMRON 3S4YR-MMW2)
- Manual smart card readers
- Relay output

ARTICLE NUMBER	
Qmatic CI 2477	10112040



Information units – displays, digital signage and audio messaging

Qmatic's Matrix displays are designed modularly making it simple to install in various combinations, without wires and cables showing. The displays can be programmed to show text in different languages, in different fonts and different colours – e.g. blue, red, green or amber. The displays can show fixed or running messages. It is possible to alternate an advertising text with a queue number, or just show the number of people waiting for a certain individual.

The audio interface works on all Qmatic systems, making it possible to play a message to call customers to the right counter. It can also be used to announce the name of the member of staff that will be serving the customer. The message can be read out in many different languages and it's simple to change the content of the message when necessary.

INFORMATION UNITS



Qmatic Display 911

The Qmatic Display 911 is the smallest display in the display concept. It can show two characters and is used as a small information display for waiting time or the number of waiting customers.

Features

- LED matrix that can show two characters
- LED available in red and green colours
- Useable with the 911 signboard
- Connectable to an external or internal buzzer
- Size: 229 x 152 mm
- LED area: 97 x 91 mm

ARTICLE NUMBER	
Qmatic Display 911 Red	10370401
Qmatic Display 911 Green	10370421



Qmatic Display 917

The Qmatic Display 917 can show three characters and is perfect as a workstation display or an information display. Using the Qmatic Display 917 means you can flash the displayed information and show information such as, ticket number, waiting time or number of waiting customers.

Features

- LED matrix that can show three characters
- LED available in red, white and green colours
- Useable with the 917 signboard
- Connectable to an external or internal buzzer
- Size: 283 x 152 mm
- LED area: 151 x 91 mm

ARTICLE NUMBER	
Qmatic Display 917 Red	10370301
Qmatic Display 917 White	10370311
Qmatic Display 917 Green	10370321

INFORMATION UNITS



Qmatic Display 924

The Qmatic Display 924 can show up to four characters depending on the font. Perfect as a workstation display or as a small information display. Stack two displays for use as one main display. Using the Qmatic Display 924 means you can show ticket numbers above the workstation and show numeric information such as waiting time and number of customers in line. You can also display called ticket numbers, workstation numbers and direction of the workstation.

Features

- 9x24 pixels LED Matrix
- Different fonts
- LED available in five colours (red, green, blue, white or red/green)
- Stackable with 924 displays and signboards
- Scroll text in any direction
- Size: 343 x 152 mm
- LED area: 214 x 91 mm

ARTICLE NUMBER	
Qmatic Display 924 Red	10340301
Qmatic Display 924 White	10340311
Qmatic Display 924 Green	10340321
Qmatic Display 924 Red-Green	10340341
Qmatic Display 924 Blue	10340361



Qmatic Display 948

The Qmatic Display 948 can show up to eight characters depending on the font. It can be used as a small main display. The display has the ability to show short fixed text messages or rolling texts. Using Qmatic Display 948 means you can show messages and ticket numbers above workstations and indicate called ticket numbers and workstation numbers.

Features

- 9x48 pixels LED Matrix
- Different fonts
- LED available in five colours (red, green, blue, white or red/green)
- Stackable with 948 displays and signboards
- Scroll text in any direction
- Size: 556 x 152 mm
- LED area: 427 x 91 mm

ARTICLE NUMBER	
Qmatic Display 948 Red	10340401
Qmatic Display 948 White	10340411
Qmatic Display 948 Green	10340421
Qmatic Display 948 Red-Green	10340441
Qmatic Display 948 Blue	10340461

INFORMATION UNITS



Qmatic Display 972

The Qmatic Display 972 can show about 12 characters depending on the font. Perfect as main display or information display with fixed or scrolling text messages. With the Qmatic Display 972 you can show fixed text messages, show scrolling text and show called ticket number, workstation number and a directional arrow towards indicated workstation.

Features

- 9×72 pixels LED Matrix
- Different fonts
- LED available in four colours (red, green, blue or three-colour)
- Stackable with 972 displays and signboards
- Scroll text in any direction
- Size: 770 x 152 mm
- LED area: 641 x 91 mm

ARTICLE NUMBER	
Qmatic Display 972 Red	10340501
Qmatic Display 972 Green	10340521
Qmatic Display 972 Red-Green	10340541
QMATIC DISPLAY 972 Blue	10340561



Qmatic Display 1632

The Qmatic Display 1632 is the smallest display of the 16 series. It can show one line with three characters or two lines with five characters on each line. The exact number of characters depends on the font. The Qmatic Display 1632 is used as an information display, main display or workstation display.

Features

- 16×32 pixels LED Matrix
- All kinds of alphabets (European, Arabic, Chinese, Japanese, Thai) and characters
- Different fonts
- LED available in five colours (red, green, blue, white or red/green)
- Stackable with 1632 displays and signboards.
- Scroll text in any direction
- Size: 343 x 152 mm
- LED area: 214 x 107 mm

ARTICLE NUMBER	
Qmatic Display 1632 Red	10350301
Qmatic Display 1632 White	10350311
Qmatic Display 1632 Green	10350321
Qmatic Display 1632 Red-Green	10350341
Qmatic Display 1632 Blue	10350361

INFORMATION UNITS



Qmatic Display 1664

The Qmatic Display 1664 can show all kinds of characters and alphabets. The number of characters depends on the font. The display can show two lines of text if a small font is used. It can also show ticket numbers and workstation numbers on a main display and scrolling text.

Features

- 16×64 pixels LED Matrix
- All kinds of alphabets (European, Arabic, Chinese, Japanese, Thai) and characters
- Different fonts
- LED available in five colours (red, green, blue, white or red/green)
- Stackable with 1664 displays and signboards
- Scroll text in any direction
- Size: 556 x 152 mm
- LED area: 427 x 107 mm

ARTICLE NUMBER	
Qmatic Display 1664 Red	10350401
Qmatic Display 1664 White	10350411
Qmatic Display 1664 Green	10350421
Qmatic Display 1664 Red-Green	10350441
Qmatic Display 1664 Blue	10350461



Qmatic Display 1696

The Qmatic Display 1696 can show all kinds of characters and alphabets. The number of characters depends on the font. The display can show two lines of text if a small font is used. The Qmatic Display 1696 is often used as information display or main display and shows ticket numbers, workstation numbers and scrolling text.

Features

- 16×96 pixels LED Matrix
- All kinds of alphabets (European, Arabic, Chinese, Japanese, Thai) and characters
- Different fonts
- LED available in four colours (red, green, red/green or blue)
- Stackable with 1696 displays and signboards
- Scroll text in any direction
- Size: 770 x 152 mm
- LED area: 641 x 107 mm

ARTICLE NUMBER	
Qmatic Display 1696 Red	10350501
Qmatic Display 1696 Green	10350521
Qmatic Display 1696 Red-Green	10350541
Qmatic Display 1696 Blue	10350561

INFORMATION UNITS



Qmatic Signboard 8/9/16 series

A display text can be difficult to understand when it is a mixture of numbers and letters. A signboard with explanatory text removes all uncertainties and readers can easily assimilate the shown information.

Features

- Can be added to all 9/16 series displays
- Elegant design that fits perfectly to the displays
- Easy to read with white text on grey background

ARTICLE NUMBER	
Qmatic Signboard to display 924 / 1632 / 832	10930001
Qmatic Signboard to display 948 / 1664 / 864	10930021
Qmatic Signboard to display 972 / 1696 / 896 / 1PC	10930041
Qmatic Signboard to display 911	10930081
Qmatic Signboard to display 917	10930101

DISPLAY ACCESSORIES

A Tubes

ARTICLE NUMBER	
Tube 10×25×500 mm	10930201
Tube 10×25×1250 mm	10930202
Tube 10×25×5000 mm	10930203

B Cover plate for tube

ARTICLE NUMBER	
Cover plate for tube 10×25	12350430

C Ceiling fastener

ARTICLE NUMBER	
Ceiling fastener	10930205

D Acoustic roof hanging system

ARTICLE NUMBER	
Acoustic roof hanging system	10930301

E Backside grove cover

ARTICLE NUMBER	
Backside grove cover	10930315

F Cable clip

ARTICLE NUMBER	
Cable clip	10930316

G Display connector

ARTICLE NUMBER	
Display connector	12350201

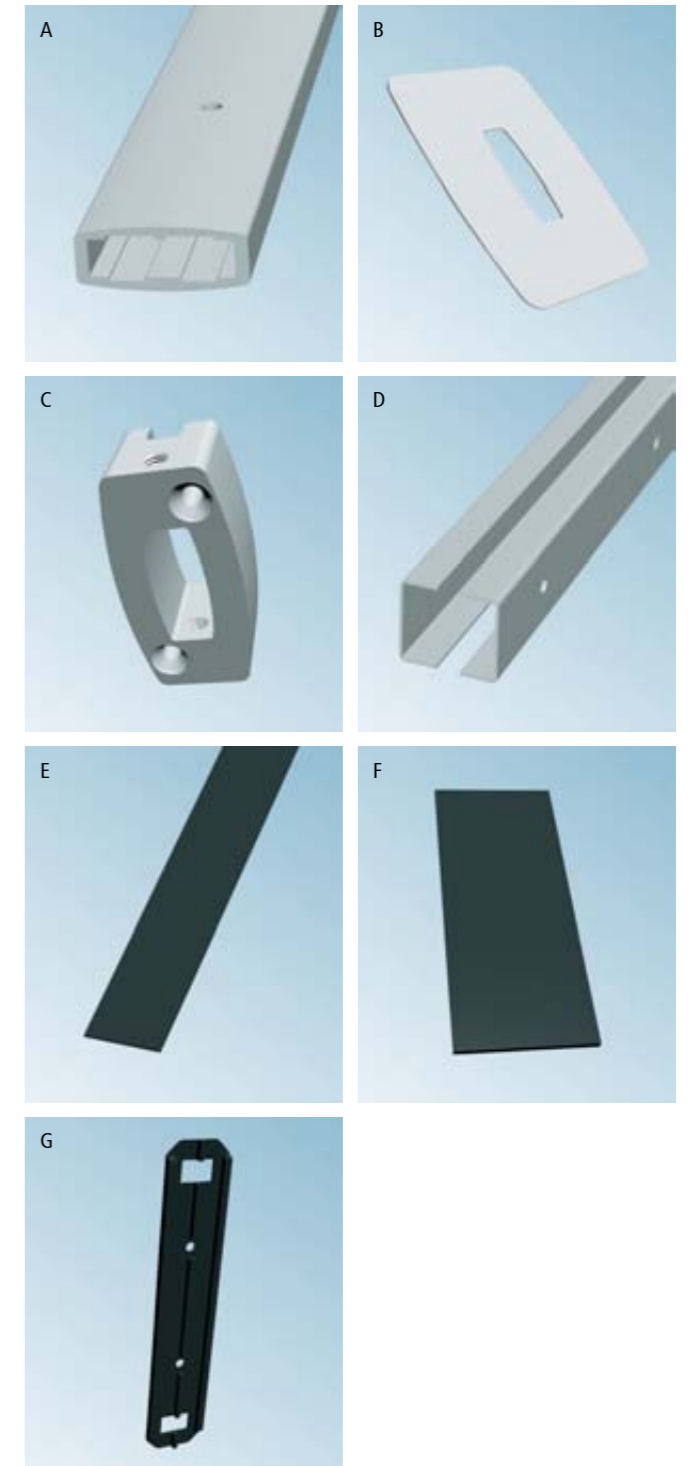

DISPLAY ACCESSORIES

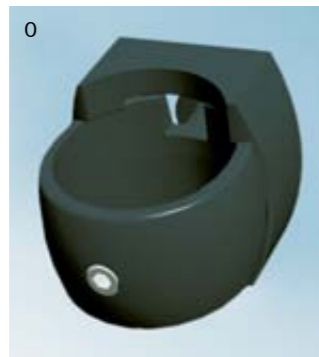
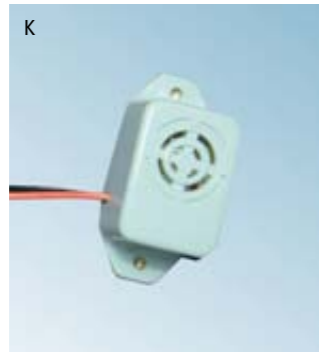
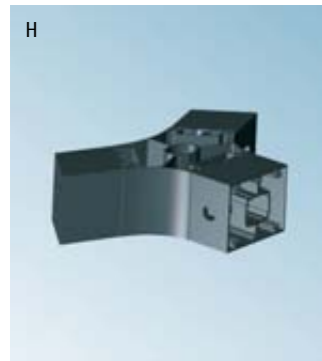

H Triangular hanging system 924/832/1632

ARTICLE NUMBER	
Triangular hanging system 924/832/1632	10930321

I Triangular hanging system 948/864/1664

ARTICLE NUMBER	
Triangular hanging system 948/864/1664	10930322

J Back to back bracket

ARTICLE NUMBER	
Back to back bracket	10930331

K Buzzer

ARTICLE NUMBER	
Buzzer	11271110

L Signboard display connector

ARTICLE NUMBER	
Signboard display connector	12260106

M Mounting bracket wall

ARTICLE NUMBER	
Mounting bracket wall	12260201

N Triangle system wall bracket

ARTICLE NUMBER	
Triangle system wall bracket 5 pcs	10930330

O Display clamp contrahold, stop screw

ARTICLE NUMBER	
Display clamp contrahold, stop screw	12350352A

P Mounting lock display

ARTICLE NUMBER	
Mounting lock display 9xx/16xx/8xx	12350380

VOICE UNITS



Interface

Qmatic Voice Unit VU 2187

Hearing a message in combination with seeing it on a display or a monitor increases the impact of the message. It adds a human dimension to the system and helps to make sure the message is understood. Staff members without visibility of the displays or monitors can be notified or informed by a voice message.

Features

- Memory with capacity to store hundreds of messages
- Output with two channels to manage two pre-recorded voice messages at the same time
- Voice messages can easily be changed or edited
- Voice messages can be played back in different languages to different groups of people in bilingual areas
- Voice messages can be played wherever they are needed; either at the ticket printer or over a public announcement system
- Melodies can be sampled for ding-dong functions

ARTICLE NUMBER	
Qmatic Voice Unit VU 2187	10117020

Workstation terminals



Workstation terminals are used to call the next customer, to show the current queue number, number of customers waiting or the actual waiting time. They can also be used to redirect customers to other tellers, to choose and prioritise various service categories and to send and receive messages. The range also includes hardware and software-based terminals depending on customer requirements.

WORKSTATION TERMINALS



Qmatic Wireless Terminal 433 MHz CE-HP/433 MHz FCC- LP

The Qmatic Wireless Terminal is used as a workstation terminal in the Qmatic systems. It is a handheld device and can be worn with the built-in belt clip and/or a neck ribbon. It is also used together with the Qmatic Multi Interface MI2280 radio. The wireless terminal can be used to remote control any function in a Qmatic Solo or a Q-WIN system (close workstations, send alarms and more).

Features

- Easy to install – no hardwiring
- Three switches
- Power saving and auto shut off
- Ergonomic and contemporary design

ARTICLE NUMBER	
Qmatic Wireless Terminal 433 MHz CE-HP	10320203
Qmatic Wireless Terminal 433 MHz FCC-LP	10320211



Qmatic KT 2695 5 buttons / KT 2695 5 buttons barcode

The Qmatic KT 2695 is an easy-to-use workstation terminal with basic functions: call customers, select priority and send alarm. The Qmatic KT 2695's display gives information about waiting times and number of waiting customers.

Features

- Reprogrammable keys
- Customisable display
- Two priority keys – change service modes as required
- Usable with Q-WIN and Qmatic Solo systems
- External connectivity (Qmatic KT 2695 with serial connector) – can be connected to barcode scanners and other devices

ARTICLE NUMBER	
Qmatic KT 2695 5 buttons	10320107
Qmatic KT 2695 5 buttons barcode	10320106

WORKSTATION TERMINALS



Qmatic KT 2595 33 buttons/ KT 2595 33 buttons barcode

The KT 2595 is a sophisticated workstation terminal that allows the users to manage customer flows more efficiently. Using the KT 2595 customers can easily be called and transferred between workstations. Priorities can be set and the display of the KT 2595 gives useful system information. With the KT 2595 you can also change priorities, send alarms to supervisor, assign matter codes to transactions and call a customer with a specific ticket number.

Features

- Reprogrammable keys
- Customisable display
- Five priority keys – change service modes as required
- Usable with Q-WIN and Qmatic Solo systems
- Track staff performance with unique login IDs
- External connectivity (KT 2595 with serial connector) – can be connected to barcode scanners and other devices

ARTICLE NUMBER	
Qmatic KT 2595 33 buttons	10320105
Qmatic KT 2595 33 buttons barcode	10320104

INTERFACES

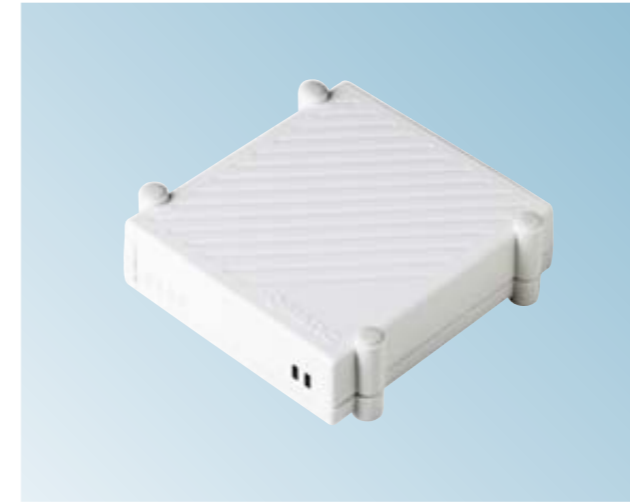

Qmatic's option of interfaces makes it possible to connect third-party devices such as sensors, alarm and security systems. It makes the Qmatic solution even more flexible.

Multi-interface Qmatic I/O*8 MI2280

The Qmatic Multi-Interface MI2280 makes it possible to connect up to eight external third-party devices to a Q-WIN system. With the Qmatic Multi interface MI2280 devices such as electronic sensors, alarms, lights or bells can be connected. Each input/output can send/receive two types of signals that allows flexible solutions.

Features

- Connectable to other devices
- Process eight inputs and eight outputs
- Versatile, protocol-free connectivity
- Surge protection – protects the systems even when Q-WIN is not running

ARTICLE NUMBER	
Multi-interface Qmatic I/O*8 MI2280	10112043

Interface Qmatic RS 232

Qmatic RS 232 is a well-known and widely used standard in communication between different kinds of equipment. Using the Qmatic RS 232 Interface means it is possible to connect a wide range of devices to Q-WIN or Qmatic Solo. It can be used both as a card reader interface and as a general multi interface. A relay makes it possible to control external equipment, like a door lock.

Features

- Send and receive data through Qmatic RS 232 serial communication
- Card reader interface
- Multi Interface
- LED and buzzer indicate correct connection to the system
- Two script program controlled Light Emitting Diodes (LED)
- Script program controlled buzzer
- Script program controlled relay

ARTICLE NUMBER	
Interface Qmatic RS 232	10112042

Multi-interface Qmatic MI2280 Radio

The Multi-Interface MI2280 Radio is a Multi-Interface with a radio receiver. It is used together with the wireless terminal. You can use it wherever you want a wireless solution, as a remote control for ticket printers, door locks and other types of equipment.

The Multi-Interface MI2280 Radio is available either on its own or as a part of a kit including three wireless terminals.

Features

- Connectable to other devices
- Processes 8 inputs and 8 outputs
- Easy to connect
- Versatile, protocol-free connectivity
- 433.92 MHz radio receiver

ARTICLE NUMBER	
Interface Qmatic MI2280 Radio	10112044

LINEAR QUEUE SYSTEMS



Linear queue systems

Linear queue systems offers the simplest solution when it does not matter which cashier you see (because they all offer the same service). Consumers are directed to the next available service point by a digital voice and visual display. So customers are served in the order they arrive. That's fair and reassuring for your customers and shows them that you value their time – a very positive brand message. With a linear queue system, you will optimise customer throughput and maintain the most efficient level of service, despite variable transaction times.

Qmatic Solo Linea

A flexible linear queue management system, Qmatic Solo Linea, brings order and fairness to many queuing situations.

The efficiency of the service will increase with more customers served per staff member. Also better utilization of the counters and improved customer flow.

The very few settings of the Qmatic Solo Linea are easily managed with a web browser.



ARTICLE NUMBER	
Qmatic Solo Linea	10213065



Guideline 45

Guideline 45 consists of a steel tube and base weight cover, cast base weight and a 2.3 metre retractable tape.

Guideline 45 combines the highest standards of engineering excellence in a tough yet stylish design with many features designed to make the product easier and more practical to use whilst ensuring it looks good for many years to come.

Steel posts and base weight covers are finished in hard-wearing epoxy powder coat.

Features

- 2.3 metre Guideline tape cartridge with four track connective.
- Retractable tape cartridge with patented Guideline retraction control system, slowing tape return to prolong cartridge life and minimising risk of accidents.
- Special, locking tape end improves safety and security.
- Compatible with most leading retractable tape barrier systems.
- Designed to maximise stability with an extremely low centre of gravity.

Accessories

- 5m Wall unit
- A4 Portrait Sign holder.

QMATIC

Qmatic, tel +46 31 756 46 00, info@qmatic.com, www.qmatic.com