User's Manual

CL155
Clamp-on Tester
クランプテスタ

IM CL155

Contents

■ Precautions for Safety Use of the Instrument -----	i
1. Instrument Layout -----	1
2. Measurement -----	3
2.1 Preparation for Measurement -----	3
2.2 Current Measurement -----	3
2.2.1 AC Current Measurement (Normal Mode) -----	4
2.2.2 Peak Current Measurement (Peak Mode) -----	4
2.3 Voltage Measurement -----	5
2.3.1 DC Voltage Measurement -----	5
2.3.2 AC Voltage Measurement -----	5
2.4 Resistance Measurement -----	6
2.4.1 Resistance Measurement (Normal Mode) -----	6
2.4.2 Continuity Check (400Ω range fixed) -----	6
3. Other Functions -----	8
3.1 Sleep Function -----	8
3.2 Data Hold Function -----	8
3.3 OUTPUT Terminal (For current measurement only) -----	9
3.4 Optional Accessories -----	10
4. Battery Replacement -----	11
5. Specifications -----	12
6. Calibration and After-sales Service -----	15

■ Precautions for Safe Use of the Instrument

When handling the instrument, ALWAYS observe all of the cautionary notes on safety given below. Yokogawa M&C Corporation is not at all liable for damage resulting from misuse of this product by the user that is contrary to these cautionary notes.

Various symbols are used on the instrument and in this manual to ensure the product is used safely and to protect operators and property from possible hazards or damage. The following safety symbols are used where appropriate. Read the explanations carefully and familiarize yourself with the symbols before reading the text.

The instrument and this manual use the following safety symbols:

Danger! Handle with Care.



This symbol indicates that the operator must refer to an explanation in the User's Manual in order to avoid the risk of personal injury or death and/or damage to the instrument.



Double Insulation

This symbol indicates double insulation.



AC Voltage/Current

This symbol indicates AC voltage or current.



DC Voltage/Current

This symbol indicates DC voltage or current.



Ground

This symbol indicates ground (earth)



WARNING

Indicates that there is a possibility of serious personal injury or loss of life if the operating procedure is not followed correctly and describes the precautions for avoiding such injury or loss of life.



CAUTION

Indicates that there is a possibility of serious personal injury or damage to the instrument if the operating procedure is not followed correctly and describes the precautions for avoiding such injury or damage.

NOTE

Draws attention to information essential for understanding the operation and features.

WARNING

- Never make measurement on a circuit above 750V AC or 1000V DC.
- Do not use the instrument in an atmosphere where any flammable or explosive gas is present.
- Do not attempt to make measurement in the presence of flammable gasses, fumes, vapor or dust. Otherwise, the use of the instrument may cause sparking, which can lead to an explosion.
- Avoid using the instrument if it has been exposed to rain or moisture or if your hands are wet.
- Do not exceed the maximum allowable input of any measurement range.
- Never open the battery compartment cover when making measurement.
- Do not use the instrument if there is any damage to the casing or when the casing is removed.
- Do not turn the Function Selector switch with plugged in test leads connected to the circuit under test.
- Do not install substitute parts or make any modification to the instrument. Return the instrument to Yokogawa M&C or your distributor for repair or re-calibration.
- Always switch off the instrument before opening the battery compartment cover for battery replacement.

WARNING

To avoid damage to the instrument or electric shock!

The restrictions on the maximum voltage level for which the CL155 testers can be used, depend on the over-voltage categories specified by the safety standards. These category specifications are formulated to protect operators against transient impulse voltage in power lines.

Function	Maximum Allowable Input		
	OVERVOLTAGE CATEGORY II	OVERVOLTAGE CATEGORY III	OVERVOLTAGE CATEGORY IV
~ A	AC 2000A rms Measuring circuit voltage : AC 750V rms	AC 2000A rms Measuring circuit voltage : AC 600V rms	AC 2000A rms Measuring circuit voltage : AC 300V rms
~ V, --- V	AC 750V rms/DC 1000V	AC 600V rms/DC 600V	AC 300V rms /DC 300V
Input terminal-to-ground voltage	AC 750V rms/DC 1000V		

Over-voltage category I (CAT.I):

Signal level, special equipment or parts of equipment, telecommunication, electronic etc., with smaller transient over-voltages than CAT.II.

Over-voltage category II (CAT.II)

Local level, appliance, portable equipment etc., with smaller transient over-voltages than CAT.III.

Over-voltage category III (CAT.III):

Distribution level, fixed installation, with smaller transient over-voltages than CAT.IV.

Over-voltage category IV (CAT.IV):

Outside and service entrance.



CAUTION

- Always make sure to insert each plug of the test leads fully into the appropriate terminal on the instrument.
 - Make sure to remove the test leads from the instrument before making current measurement.
 - Be sure to set the Function Selector switch to the "OFF" position after use. When the instrument will not be in use for a long period of time, Place it in storage after removing the battery.
 - Use a damp cloth and detergent for cleaning the instrument. Do not use abrasives or solvents.
-
-

NOTE

- Radiation immunity affects the accuracy of CL155 testers under the conditions specified in EN 61000-4-3:1997.
- If equipment generating strong electromagnetic interference is located nearby, the testers may malfunction.

1. Instrument Layout

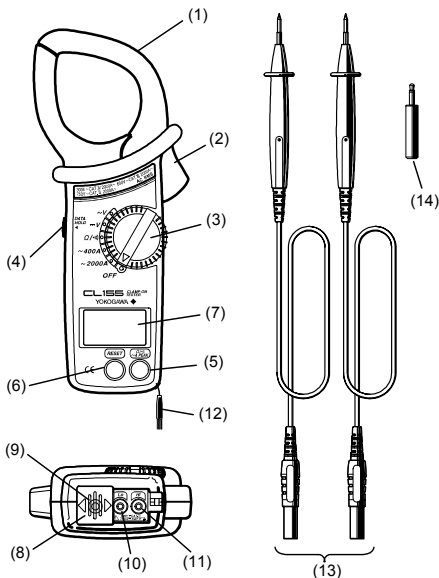

- (1) Transformer Jaws : Pick up current flowing through the conductor.
- (2) Open/Close Lever : Operates the transformer jaws. Press to open the Transformer Jaws.
- (3) Function Selector Switch : Selects ranges. Also used to power the instrument on.
- (4) Data Hold Button : Freezes the display reading. "**H**" is shown on the display when Data Hold is enabled.
- (5)  Mode Selector Button : On a AC current (" $\sim 400A$ " or " $\sim 2000A$ " or the resistance (Ω/\bullet)) range. Press the mode button to cycle through the measurement modes. The instrument is initially set to the normal mode and can be switched to peak or continuity check mode by means of the mode button.

$\sim A / \sim V$ (ACA/ACV)	Display	$\Omega / \bullet))$ (Resistance/Continuity)	Display
→ Normal ↓ Peak	PEAK	→ Resistance ↓ Continuity check	Ω $\bullet))$

- (6) **RESET** Button : Reset the measurement in peak mode.
- (7) LCD Display : Field effect type of liquid crystal display with maximum counts of 3999. Function symbols and decimal point are controlled by the microprocessor based on the selected function and measuring mode.

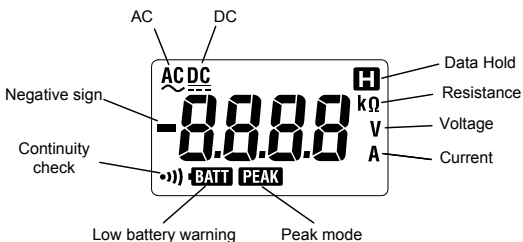

- (8) Terminal Cover : Slides over Hi and Lo Terminals to prevent access to them when OUTPUT terminal is in use.
- (9) OUTPUT Terminal (For " $\sim 400A$ " or " $\sim 2000A$ " range only) : Provides DC voltage output in proportion to the AC or DC current reading. The output is connected to a recording device such as a chart recorder for long hour monitoring. No output is available on voltage and resistance ranges.
- (10) Lo Terminal : Accepts the black test lead for voltage or resistance measurement.
- (11) Hi Terminal : Accepts the red test lead for voltage or resistance measurement.
- (12) Safety Hand Strap : Prevents the instrument from slipping off the hand during use.
- (13) Test Leads (Model 98011) : Connected to Lo and Hi terminals for voltage or resistance measurement.
- (14) Output Plug (Model 98012) : Plugs into the OUTPUT terminal for connection to a recording device. (See section 3.3, OUTPUT Terminal.)

2. Measurement

2.1 Preparation for Measurement

CAUTION

- The jaw section is a delicate, precision sensor. Do not subject the jaw to unreasonably strong shock, vibration, or force when using it.
- If dust gets into the tops of the jaws, remove it immediately. Do not close the jaws when dust is trapped in its joints as the sensor may break.
- Please check that the function and mode are set to the desired setting before measurement.

2.2 Current Measurement

WARNING

- Do not make measurement on a circuit above 750VDC. This may cause shock hazard or damage to the instrument or equipment under test.
- Do not make current measurement with the test leads connected to the Hi and Lo terminals.
- When measuring current is not less than 1000A, make sure to stop measurement within the maximum measuring time shown below.
Otherwise, transformer jaws may heat to cause a fire or deformation of molded parts, which will degrade insulation.
1000 to 1500A : 15min. 1500 to 2000A : 5min.

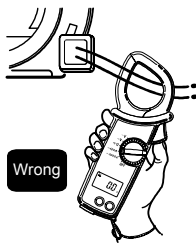
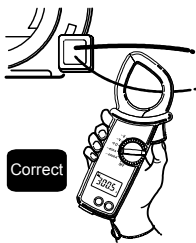



2.2.1 AC Current Measurement (Normal Mode)

- (1) Set the Function Selector switch to the " $\sim 400A$ " or " $\sim 2000A$ " position. "AC" should be shown on the upper left corner of the display.
- (2) Press the open/close lever to open the transformer jaws and clamp them onto the conductor under test, then take the reading on the display. The most accurate reading will be obtained by keeping the conductor at the center of the transformer jaws.

NOTE

- During current measurement, keep the transformer jaws fully closed. Otherwise, accurate measurement cannot be made. The maximum measurable conductor size is approx. 54.5mm in diameter.
- The transformer jaws may buzz when measuring large current. This has no effect on the instrument's performance or safety.

2.2.2 Peak Current Measurement (Peak Mode)

- (1) Set the Function Selector switch to the " $\sim 400A$ " or " $\sim 2000A$ " position.
- (2) Press the  button once to enter from the normal mode to the PEAK mode. "PEAK" should be shown on the display.
- (3) Press the open/close lever to open the transformer jaws and clamp them onto the conductor under test. Then, press the  button.
- (4) The display shows the current's crest value divided by the square root of two. Therefore, when the current is sinusoidal, the reading equals RMS value.
- (5) To reset the display, press the  button.

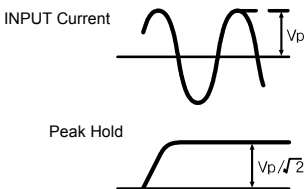

- (6) After the measurement is over, press the  button to return to the normal mode.

NOTE

- In the Peak measurement mode, the data hold feature is disabled.
- In the Peak measurement mode, the response time is 10ms.

2.3 Voltage Measurement



WARNING

Do not make measurement on a circuit above 750V AC or 1000V DC. This may cause shock hazard or damage to the instrument or equipment under test.

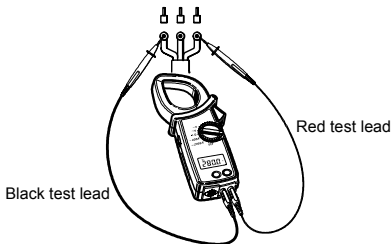

2.3.1 DC Voltage Measurement

- (1) Set the Function Selector switch to the " $\text{---}V$ " position. "DC" should be shown on the upper left corner of the display.
- (2) Slide the terminal cover to the left to disclose the Hi and Lo terminals. Plug the red test lead into the Hi terminal and the black test lead into Lo terminal.
- (3) Connect the tip of the red and black test leads to the positive (+) and negative (-) sides of the circuit under test respectively. Take the reading on the display.

2.3.2 AC Voltage Measurement

- (1) Set the Function Selector switch to the " $\sim V$ " position. "AC" should be shown on the upper left corner of the display.
- (2) Slide the terminal cover to the left to disclose the Hi and Lo terminals. Plug the red test lead into the Hi terminal and the black test lead into Lo terminal.
- (3) Connect the tip of the test leads to the circuit under test respectively. Take the reading on the display.

NOTE

For high sensitivity, there are parts which do not indicate "0".

2.4 Resistance Measurement (Normal Mode)

WARNING

Never use the instrument on an energized circuit.

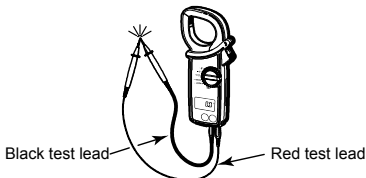

2.4.1 Resistance Measurement (Normal Mode)

- (1) Set the Function Selector switch to the " Ω / \bullet)" position. The " Ω " should be shown on the upper right corner of the display.
- (2) Slide the terminal cover to the left to disclose the Hi and Lo terminals. Plug the red test lead into the Hi terminal and the black test lead into the Lo terminal. Check that "OL" (over indication) is indicated on the LCD display.
- (3) Short the tip of the test leads and check whether the display reads "0".
- (4) Connect the tip of the test leads to the circuit under test respectively. Take the reading on the display.

NOTE

When shorting the tip of the test leads, the display may read a very small resistance instead of "0". This is the resistance of the test leads on the display.

2.4.2 Continuity Check (400 Ω range fixed)

The continuity check mode is enabled by pressing the  button on resistance range. " \bullet)" and " Ω " is indicated on the display to show the instrument in the continuity check mode. The buzzer beeps, if the resistance under test is 50 Ω or less.

- (1) Set the Function Selector switch to the " Ω / \bullet)" position.
- (2) Slide the terminal cover to the left to disclose the Hi and Lo terminals. Plug the red test lead into the Hi terminal and the black test lead into the Lo terminal. Check that "OL" (over indication) is indicated on the LCD display.

- (3) Press the  button once to enter from the normal mode to the continuity check mode. "•))" should be indicated on the display.
- (4) Short the tip of the test leads and check whether the display reads "0".
- (5) Connect the tip of the test leads to the circuit under test. If the resistance is 50Ω or less, the buzzer beeps.



NOTE

When shorting the tip of the test leads, the display may read a very small resistance instead of "0". This is the resistance of the test leads on the display.

3. Other Functions

3.1 Sleep Function

This is a function to prevent the instrument from being left powered on in order to conserve battery life. This function causes the instrument to enter the Sleep (powered-down) mode about 10 minutes after the last switch or button operation.

To exit the Sleep mode, press the Data hold,  button or  button or turn the Function Selector switch back to "OFF", then to any other position, or press any button.

The current is consumed a little in the Sleep mode.

How to Exit the Sleep Mode

Turn the Function Selector switch from "OFF" to another position with the data hold function button pressed. Then, "P.OFF" is shown on the display. This disables the sleep function and enables continuous use of the instrument.

NOTE

- Connecting the plug to the OUTPUT terminal disables the Sleep function. The function is enabled on removing the plug from the terminal.
- The Sleep function is disabled in the PEAK measurement mode.

3.2 Data Hold Function

This is a function used to freeze the measured value on the display. Press the Data Hold button to freeze the reading. The reading will be held regardless of subsequent variation in input. " " is shown on the upper right corner of the display while the instrument is in the Data Hold mode.

To exit the Data Hold mode, press the Data Hold button again.

NOTE

- The Data hold function is disabled in the peak measurement mode on the AC current range.
- When the Sleep function is activated, the Data hold mode turns to the normal mode.

3.3 OUTPUT Terminal (For current ranges only)

WARNING

- Never use the instrument on a circuit above 750VAC or 1000VDC. This may cause electrical shock hazard and damage to the instrument or the circuit under test.
- Never apply voltage to the OUTPUT terminal.

Only on the " \sim 400A" or " \sim 2000A" range, DC voltage proportional to the input current is output from the OUTPUT terminal.

- (1) Attach the output plug to a connection lead so that the output voltage can be connected to a recording device such as a chart recorder.



- (2) Slide the terminal cover to the right to disclose the OUTPUT terminal and insert the output plug into the terminal. Make connection to the recording device.

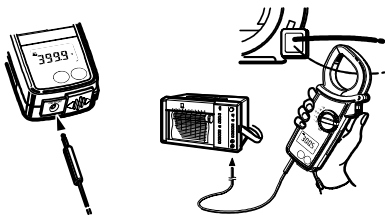

- (3) Set the Function Selector switch to the " \sim 400A" or " \sim 2000A" position and follow appropriate measurement instructions.

NOTE

- Output voltage is 1mV/A on the " \sim 400A" range and 0.1mV/A on the " \sim 2000A" range. Set an appropriate input sensitivity on the recorder.
- The peak hold function does not apply to the recorder output even if the instrument is in the peak hold mode.
- For long term measurement, disable the sleep function.

3.4 Optional Accessories

Clamp Adapter Model 99025 (For AC current measurement only)

Clamp Adapter Model 99025 is designed to increase the measuring capability of a clamp meter. With the use of the Clamp Adapter, you can not only extend current range over 3000A, but also clamp on a large bus-bar or conductor.

- (1) Set the Function Selector switch to the " \sim A " position.
- (2) As shown in the figure below, clamp Model CL155 onto the pickup coil of Model 99025.
- (3) Clamp Model 99025 onto the bus-bar or conductor under test.
- (4) Take the reading on Model CL155 and multiply it by 10.

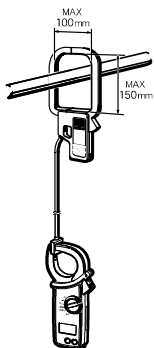

NOTE

For the detailed specification, refer to the Clamp Adapter User's Manual.

4. Battery Replacement

WARNING

To avoid electric shock hazard, make sure to set the Function Selector switch to "OFF" and remove the test leads from the instrument before trying to replace battery.

CAUTION

-
- Do not mix new and old batteries.
 - Make sure to install battery in correct polarity as indicated in battery compartment.
-

If the battery voltage becomes too low for the instrument to operate normally, "**BATT**" is shown on the display. Then, replace the battery. Note that when the battery is completely exhausted, the display blanks without "**BATT**" shown.

- (1) Set the Function Selector switch to the "OFF" position.
- (2) Unscrew and remove the battery compartment on the bottom of the instrument.
- (3) Replace the battery observing correct polarity. Use two new R6P batteries.
- (4) Re-place and screw the battery compartment cover.

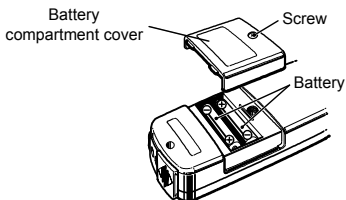

5. Specifications

■ Instrument Specifications

- Measuring Ranges and Accuracy (at $23 \pm 5^\circ\text{C}$, 45 to 75% relative humidity)

AC Current $\sim 400\text{A}$, $\sim 2000\text{A}$

Ranges	Measuring range	Resolution	Accuracy (frequency range)	Maximum Measurement Time
400A	0 to 400.0A	0.1A	$\pm 1.0\%$ rdg ± 3 dgt (50/60Hz) *1 $\pm 2.0\%$ rdg ± 3 dgt (40 to 1kHz)	Continuous
2000A	0 to 1000A	1A	$\pm 1.0\%$ rdg ± 3 dgt (50/60Hz) *1	
	1000 to 1500A		$\pm 3.0\%$ rdg ± 3 dgt (40 to 1kHz)	15min.
	1500 to 2000A		$\pm 3.0\%$ rdg (50/60Hz)	5min.

Conversion method : AC coupled, true rms responding, calibrated to the rms

*1 : 400A range : 5 to 100% of range , 2000A range : 200A to 2000A

AC Voltage ($\sim V$) Auto-ranging

Range	Measuring range	Resolution	Accuracy
40V	0 to 40.00V	0.01V	$\pm 1.0\%$ rdg ± 2 dgt (50/60Hz) $\pm 1.5\%$ rdg ± 3 dgt (40 to 1kHz)
400V	15.0 to 400.0V	0.1V	
750V	150 to 750V	1V	

Conversion method : AC coupled, true rms responding, calibrated to the rms

Initially set to the 40V range. Input impedance is about $1\text{M}\Omega$.

DC Voltage ($\text{---} V$) Auto-ranging

Range	Measuring range	Resolution	Accuracy
40V	0 to $\pm 40.00\text{V}$	0.01V	$\pm 1.0\%$ rdg ± 2 dgt
400V	15.0 to $\pm 400.0\text{V}$	0.1V	
1000V	150 to $\pm 1000\text{V}$	1V	

Initially set to the 40V range. Input impedance is about $1\text{M}\Omega$.

Resistance (Auto-ranging)

Range	Measuring range	Resolution	Accuracy
400 Ω	0 to 400.0 Ω	0.1 Ω	$\pm 1.5\%$ rdg ± 2 dgt
4k Ω	0.150 to 4.000k Ω	1 Ω	
40k Ω	1.50 to $\pm 40.00\text{k}\Omega$	10 Ω	
400k Ω	15.0 to $\pm 400.0\text{k}\Omega$	100 Ω	

Initially set to the 400 Ω range. In the continuity check mode, fixed to the 400 Ω range and when the reading is not more than $.50 \pm 35\Omega$, the buzzer beeps.

Peak Current (10ms)

Range	Measuring range	Accuracy (Frequency Range)
400A	0 to 400.0A	$\pm 3.0\%$ rdg ± 6 dgt (50/60Hz) $\pm 3.0\%$ rdg ± 10 dgt (40 to 1kHz)
2000A	0 to 1500A	$\pm 4.0\%$ rdg ± 6 dgt (50/60Hz) $\pm 4.0\%$ rdg ± 10 dgt (40 to 1kHz)
	1500 to 2000A	$\pm 4.5\%$ rdg (50/60Hz)

OUTPUT (AC Current Ranges)

DC Output : 100.0mV per 1000 counts (Output impedance : about 10k Ω)

Range	Measuring range	Accuracy (Frequency Range)
400A	0 to 400.0mV/0 to 400A	$\pm 1.5\%$ rdg ± 0.5 mV (50/60Hz) *1 $\pm 2.5\%$ rdg ± 0.5 mV (40 to 1kHz)
2000A	0 to 150.0mV/0 to 1500A	$\pm 1.5\%$ rdg ± 0.5 mV (50/60Hz) *1 $\pm 3.5\%$ rdg ± 0.5 mV (40 to 1kHz)
	150.0 to 200.0mV/1500 to 2000A	$\pm 3.5\%$ rdg (50/60Hz)

*1 : 400A range : 5 to 100% of range , 2000A range : 200A to 2000A

■ General Specifications

- Operating System : Dual integration
- Measurement Function : AC current, DC current, AC voltage, resistance, continuity check
- Display : Liquid crystal display with maximum counts of 3999
- Overrange Indication : "OL" is shown on the display
- Response Time : Approx. 2 seconds.
- Temperature and Humidity for Guaranteed Accuracy : 23°C ±5°C, relative humidity 45 to 75% without condensation
- Operating Temperature and Humidity : 0 to 40°C, relative humidity up to 85% without condensation
- Storage Temperature and Humidity : -20 to 60°C, relative humidity up to 85% without condensation
- Effect of conductor position : At every part inside the jaws

Range	Measuring range	Conductor size	Effect of conductor position
400A	0 to 400A	φ10mm or less	±2.0%rdg ±3dgt
2000A	0 to 1500A	φ25mm or less	±2.0%rdg ±3dgt
	1500 to 2000A	φ25mm or less	±5.0%rdg

- Effect of external magnetic field : 1A or less in AC or DC magnetic field of 400 A/m
- Power Source : Two R6P 1.5V battery
- Battery Life : Approx. 80 hours (continuity)
- Current Consumption : Approx. 7mA max. (Sleep function : Approx. 20μA)
- Sleep function : Automatically powered down in Approx. 10 minutes after the last switch operation
- Withstanding Voltage : 5500V AC, 50/60Hz for 1 minute between electrical circuit and housing case or metal part of the jaws
- Insulation Resistance : 10MΩ or greater at 1000V between electrical circuit and housing case or metal part of the jaws
- Conductor Size : Approx. 54.5mm diameter max.
- Dimensions : Approx. 105(W) x 250(H) x 49(D) mm
- Weight : Approx. 470g (with batteries)
- Safety Standard: EN 61010-1
EN 61010-2-031
EN 61010-2-032
AC/DC300V CAT IV, AC/DC 600V CAT III,
AC/DC 1000V CAT II, Pollution degree2, indoor use
- EMC Standard : EN 61326
EN 55022

- Accessories : Test leads Model 98011..... 1set
 R6P batteries 2
 Carrying case Model 93034 1
 Output Plug Model 98012..... 1
 User's Manual 1
- Optional Accessories : Clamp adapter Model 99025
 Output cable for terminal screw Model 91019

6. Calibration and After-sales Service

Should any failure occur while you are using the tester, follow the instructions given below. If the tester still fails to operate correctly and needs repair, contact the vendor from whom you purchased the instrument or the nearest Yokogawa M&C sales office.

- Turn off the POWER switch once, then turn it back on again.
- If the tester does not turn on, replace the battery with a new one.

Calibration

It is recommended that the instrument be calibrated once every year.

YOKOGAWA M&C CORPORATION

International Sales Dept.

2-9-32 Nakacho, Musashino-shi, Tokyo, 180-8750 Japan
Phone: 81-422-52-5716 Facsimile: 81-422-55-8654

YOKOGAWA CORPORATION OF AMERICA (U.S.A.)

Phone: 1-770-253-7000 Facsimile: 1-770-251-2088

YOKOGAWA EUROPE B. V. (THE NETHERLANDS)

Phone: 31-334-64-1611 Facsimile: 31-334-64-1610

YOKOGAWA AMERICA DO SUL S. A. (BRAZIL)

Phone: 55-11-5681-2400 Facsimile: 55-11-5681-1274

YOKOGAWA ENGINEERING INSTRUMENTS KOREA CORPORATION (KOREA)

Phone: 82-2-551-0660 to -0664 Facsimile: 82-2-551-0665

YOKOGAWA AUSTRALIA PTY. LTD. (AUSTRALIA)

Phone: 61-2-9805-0699 Facsimile: 61-2-9888-1844

YOKOGAWA BLUE STAR LTD. (INDIA)

Phone: 91-80-227-1513 Facsimile: 91-80-227-4270

LTD. YOKOGAWA ELECTRIC (RUSSIAN FEDERATION)

Phone: 7-095-737-7868 Facsimile: 7-095-737-7869

計測機器営業部

〒180-8750 東京都武蔵野市中町 2-9-32
電話：0422-52-5984 ファクシミリ：0422-55-8953

関西支店

〒564-0063 大阪府吹田市江坂町 1-23-101 大同生命江坂ビル 10 階
電話：06-6368-7041 ファクシミリ：06-6368-7045

中部支店

〒450-0003 名古屋市中区名駅南 1-27-2 日本生命笹島ビル 12 階
電話：052-581-7490 ファクシミリ：052-581-7664

広島営業所

〒730-0037 広島市中区中町 8-12 広島グリーンビル 8 階
電話：082-240-7676 ファクシミリ：082-541-4567

九州営業所

〒812-0037 福岡市博多区御供所町 3-21 大博通りビジネスセンター 7 階
電話：092-262-5740 ファクシミリ：092-262-5741

本社

〒180-5679 東京都武蔵野市中町 2-9-32
電話：0422-52-5679 ファクシミリ：0422-51-8455