

R&S®NRP

USB and LAN Power Sensors

Specifications



CONTENTS

Definitions	3
Overview of the R&S®NRP power sensors	4
Specifications in brief of the R&S®NRP power sensors	5
Rohde & Schwarz multipath power sensors	6
R&S®NRP8S(N)/18S(N)/33S(N) multipath power sensors R&S®NRP33SN-V multipath power sensor for use in thermal vacuum	6
R&S®NRP40S(N)/50S(N) multipath power sensors.....	9
Additional characteristics of the R&S®NRPxxS(N) multipath power sensors and the R&S®NRP33SN-V multipath power sensor for use in thermal vacuum.....	12
Accessories for R&S®NRP power sensors	15
R&S®NRP-ZKU interface cables.....	15
R&S®NRP-ZK6 interface cables	15
R&S®NRP-ZAP1 Gigabit Ethernet switch with Power-over-Ethernet (PoE) capability	15
General data	16
Appendix.....	17
Reading the uncertainty of multipath power sensors for relative power measurements	17
Technical drawings of the R&S®NRP33SN-V multipath power sensor for use in thermal vacuum	18
Ordering information	19
Footnotes.....	20

Definitions

Product data applies under the following conditions:

- Three hours storage at the expected operating temperature followed by 30 minutes warm-up, unless otherwise stated
- Specified environmental conditions met
- Recommended calibration interval adhered to
- All internal automatic adjustments performed, if applicable

Specifications with limits

Describe warranted product performance by means of a range of values for the specified parameter. These specifications are marked with limiting symbols such as $<$, \leq , $>$, \geq , \pm , or descriptions such as maximum and minimum.

Specifications in normal print refer to parameters where compliance is ensured by the design or derived from the measurement of related parameters.

Specifications in **bold** print are 100 % tested. Test limits have been narrowed by guard bands to take into account measurement uncertainties, drift and aging, if applicable.

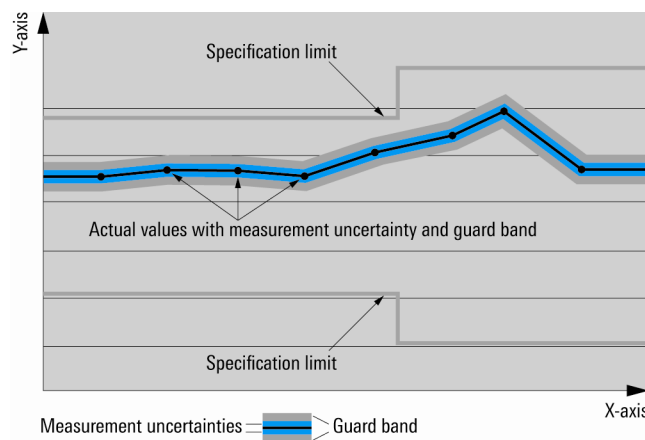

Specifications without limits

Describe warranted product performance by means of a representative value for the specified parameter. Limits are omitted whenever they are not relevant for the specification (e.g. dimensional data).

Typical values (typ.)

Represent the population mean for the given parameter, derived from the design and/or production testing. Typical values are not warranted by Rohde & Schwarz.

Limits of uncertainty

Expanded uncertainties with a coverage factor of 2, calculated from the test assembly specifications and the modeled behavior of the sensor, including environmental conditions, aging, wear and tear, if applicable. The given values represent limits of uncertainty that are met by the Rohde & Schwarz instrument after calibration at a production or service site. Limits of uncertainty (in italics) are defined in EN 60359 and have been determined in line with the rules of the Guide to the Expression of Uncertainty in Measurement (GUM).

Overview of the R&S® NRP power sensors

Sensor type R&S®	Frequency range	Power range, max. average power / peak envelope power	Connector type
Multipath power sensors			
NRP8S(N)	10 MHz to 8 GHz	100 pW to 200 mW (–70 dBm to +23 dBm) max. 1 W (AVG) / 2 W (PK, 10 µs)	N
NRP18S(N)	10 MHz to 18 GHz	100 pW to 200 mW (–70 dBm to +23 dBm) max. 1 W (AVG) / 2 W (PK, 10 µs)	N
NRP33S(N)/ NRP33SN-V	10 MHz to 33 GHz	100 pW to 200 mW (–70 dBm to +23 dBm) max. 1 W (AVG) / 2 W (PK, 10 µs)	3.50 mm
NRP40S(N)	50 MHz to 40 GHz	100 pW to 100 mW (–70 dBm to +20 dBm) max. 200 mW (AVG) / 1 W (PK, 10 µs)	2.92 mm
NRP50S(N)	50 MHz to 50 GHz	100 pW to 100 mW (–70 dBm to +20 dBm) max. 200 mW (AVG) / 1 W (PK, 10 µs)	2.40 mm

Specifications in brief of the R&S® NRP power sensors

Sensor type R&S®	Impedance matching (SWR)	Rise time Video BW	Zero offset (typ.)	Noise (typ.)	Uncertainty for power measurements at +20 °C to +25 °C	
					absolute	relative
Multipath power sensors						
NRP8S(N)	10 MHz to 2.4 GHz: < 1.13 > 2.4 GHz to 8.0 GHz: < 1.20	< 5 μ s > 100 kHz	28 pW	20 pW	0.053 dB to 0.065 dB	0.022 dB to 0.050 dB
NRP18S(N)	10 MHz to 2.4 GHz: < 1.13 > 2.4 GHz to 8.0 GHz: < 1.20 > 8.0 GHz to 18.0 GHz: < 1.25				0.053 dB to 0.094 dB	0.022 dB to 0.069 dB
NRP33S(N)/ NRP33SN-V	10 MHz to 2.4 GHz: < 1.13 > 2.4 GHz to 8.0 GHz: < 1.20 > 8.0 GHz to 18.0 GHz: < 1.25 > 18.0 GHz to 26.5 GHz: < 1.30 > 26.5 GHz to 33.0 GHz: < 1.35				0.053 dB to 0.134 dB	0.022 dB to 0.136 dB
NRP40S(N)	50 MHz to 2.4 GHz: < 1.13 > 2.4 GHz to 8.0 GHz: < 1.20 > 8.0 GHz to 18.0 GHz: < 1.25 > 18.0 GHz to 26.5 GHz: < 1.30 > 26.5 GHz to 33.0 GHz: < 1.35 > 33.0 GHz to 40.0 GHz: < 1.37				0.073 dB to 0.138 dB	0.028 dB to 0.142 dB
NRP50S(N)	50 MHz to 2.4 GHz: < 1.13 > 2.4 GHz to 8.0 GHz: < 1.20 > 8.0 GHz to 18.0 GHz: < 1.25 > 18.0 GHz to 26.5 GHz: < 1.30 > 26.5 GHz to 33.0 GHz: < 1.35 > 33.0 GHz to 40.0 GHz: < 1.37 > 40.0 GHz to 50.0 GHz: < 1.40				0.073 dB to 0.183 dB	0.028 dB to 0.184 dB

Rohde & Schwarz multipath power sensors

R&S®NRP8S(N)/18S(N)/33S(N) multipath power sensors

R&S®NRP33SN-V multipath power sensor for use in thermal vacuum

Specifications from 10 MHz to 8 GHz apply to the R&S®NRP8S(N).

Specifications from 10 MHz to 18 GHz apply to the R&S®NRP18S(N).

Specifications from 10 MHz to 33 GHz apply to the R&S®NRP33S(N)/33SN-V.

Frequency range	R&S®NRP8S(N)	10 MHz to 8 GHz	
	R&S®NRP18S(N)	10 MHz to 18 GHz	
	R&S®NRP33S(N)/33SN-V	10 MHz to 33 GHz	
Impedance matching (SWR)	10 MHz to 2.4 GHz	< 1.13 (1.11)	(): +15 °C to +35 °C
	> 2.4 GHz to 8.0 GHz	< 1.20 (1.18)	
	> 8.0 GHz to 18.0 GHz	< 1.25 (1.23)	
	> 18.0 GHz to 26.5 GHz	< 1.30 (1.28)	
	> 26.5 GHz to 33.0 GHz	< 1.35 (1.33)	
Power measurement range	continuous average	100 pW to 200 mW (–70 dBm to +23 dBm)	
	burst average	300 nW to 200 mW (–35 dBm to +23 dBm)	
	timeslot/gate average	300 pW to 200 mW (–65 dBm to +23 dBm) ¹	
	trace	2 nW to 200 mW (–57 dBm to +23 dBm) ²	
Max. power	average power	1 W (+30 dBm) AVG, max. 10 V DC	
	peak envelope power	2 W (+33 dBm) for max. 10 µs	
Measurement subranges	path 1	–70 dBm to –15 dBm	
	path 2	–53 dBm to +5 dBm	
	path 3	–33 dBm to +23 dBm	
Transition regions	with automatic path selection ³	(–20 ± 1) dBm to (–14 ± 1) dBm (0 ± 1) dBm to (+6 ± 1) dBm	
Dynamic response	video bandwidth	> 100 kHz (150 kHz)	(): +15 °C to +35 °C
	rise time 10%/90%	< 5 µs (3 µs)	
Acquisition	sample rate (continuous)	2 Msps	
Triggering	internal		
	threshold level range	–38 dBm to +23 dBm	
	threshold level accuracy	identical to uncertainty for absolute power measurements	
	threshold level hysteresis	0 dB to 10 dB	
	dropout ⁴	0 s to 10 s	
	external	EXTernal[1]: R&S®NRP2 or R&S®NRP-Z5 EXTernal2: coaxial trigger I/O	
	slope (external, internal)	pos./neg.	
	delay	–5 s to +10 s	
	hold-off	0 s to 10 s	
	resolution (delay, hold-off, dropout)	0.5 µs (sample period)	
	source	INTernal, EXTernal[1], EXTernal2, IMMEDIATE, BUS, HOLD	
	Zero offset	initial, without zeroing	
path 1		< 250 [235] (50) pW	
path 2		< 10.5 [10.3] (2.2) nW	
path 3		< 1.10 [0.93] (0.19) µW	
after external zeroing ⁵			
path 1		< 53 [49] (28) pW	
path 2		< 2.2 [2.1] (1.3) nW	
path 3	< 224 [192] (108) nW		
Zero drift ⁶	path 1	< 13 [12] (2) pW	
	path 2	< 0.6 [0.5] (0.1) nW	
	path 3	< 54 [47] (8) nW	
Measurement noise ⁷	path 1	< 37 [35] (20) pW	
	path 2	< 1.6 [1.5] (0.9) nW	
	path 3	< 158 [136] (76) nW	

Uncertainty for absolute power measurements ⁸ in dB

10 MHz to < 20 MHz

0.224	0.187	0.181
0.098	0.087	0.085
0.058	0.053	0.053

-70 -20 0 +23
Power level in dBm

20 MHz to < 100 MHz

0.195	0.177	0.172
0.089	0.085	0.083
0.055	0.054	0.054

-70 -20 0 +23
Power level in dBm

0 °C to +50 °C
+15 °C to +35 °C
+20 °C to +25 °C

100 MHz to 2.4 GHz

0.161	0.168	0.163
0.084	0.086	0.085
0.060	0.059	0.060

-70 -20 0 +23
Power level in dBm

> 2.4 GHz to 8 GHz

0.162	0.168	0.164
0.088	0.089	0.088
0.065	0.063	0.064

-70 -20 0 +23
Power level in dBm

0 °C to +50 °C
+15 °C to +35 °C
+20 °C to +25 °C

> 8 GHz to 12.4 GHz

0.166	0.172	0.166
0.096	0.096	0.095
0.076	0.073	0.074

-70 -20 0 +23
Power level in dBm

> 12.4 GHz to 18 GHz

0.174	0.182	0.178
0.110	0.111	0.112
0.092	0.090	0.094

-70 -20 0 +23
Power level in dBm

0 °C to +50 °C
+15 °C to +35 °C
+20 °C to +25 °C

> 18 GHz to 26.5 GHz

0.178	0.194	0.196
0.112	0.117	0.125
0.093	0.093	0.105

-70 -20 0 +23
Power level in dBm

> 26.5 GHz to 33 GHz

0.194	0.217	0.226
0.131	0.138	0.155
0.114	0.114	0.134

-70 -20 0 +23
Power level in dBm

0 °C to +50 °C
+15 °C to +35 °C
+20 °C to +25 °C

Uncertainty for relative power measurements ⁹ in dB

10 MHz to < 20 MHz

+23	0.267	0.239	0.027
	0.107	0.097	0.026
+6	0.047	0.041	0.026
0	0.260	0.028	0.239
	0.103	0.024	0.097
-14	0.044	0.023	0.041
-20	0.022	0.260	0.267
	0.022	0.103	0.107
-70	0.022	0.044	0.047
	-70	-20	-14
		0	+6
			+23

Power level in dBm

20 MHz to < 100 MHz

+23	0.242	0.228	0.027
	0.100	0.096	0.026
+6	0.045	0.041	0.026
0	0.235	0.028	0.228
	0.097	0.024	0.096
-14	0.043	0.023	0.041
-20	0.022	0.235	0.242
	0.022	0.097	0.100
-70	0.022	0.043	0.045
	-70	-20	-14
		0	+6
			+23

Power level in dBm

0 °C to +50 °C
+15 °C to +35 °C
+20 °C to +25 °C

100 MHz to 2.4 GHz

+23	0.213	0.217	0.027
	0.093	0.093	0.026
+6	0.045	0.040	0.026
0	0.208	0.028	0.217
	0.090	0.024	0.093
-14	0.043	0.023	0.040
-20	0.022	0.208	0.213
	0.022	0.090	0.093
-70	0.022	0.043	0.045
	-70	-20	-14
		0	+6
			+23

Power level in dBm

> 2.4 GHz to 8 GHz

+23	0.211	0.214	0.027
	0.095	0.093	0.026
+6	0.050	0.042	0.026
0	0.205	0.028	0.214
	0.092	0.024	0.093
-14	0.047	0.023	0.042
-20	0.022	0.205	0.211
	0.022	0.092	0.095
-70	0.022	0.047	0.050
	-70	-20	-14
		0	+6
			+23

Power level in dBm

0 °C to +50 °C
+15 °C to +35 °C
+20 °C to +25 °C

> 8 GHz to 12.4 GHz

+23	0.212	0.215	0.029
	0.099	0.097	0.027
+6	0.056	0.048	0.027
0	0.207	0.029	0.215
	0.095	0.025	0.097
-14	0.052	0.024	0.048
-20	0.022	0.207	0.212
	0.022	0.095	0.099
-70	0.022	0.052	0.056
	-70	-20	-14
		0	+6
			+23

Power level in dBm

> 12.4 GHz to 18 GHz

+23	0.219	0.223	0.034
	0.109	0.108	0.033
+6	0.069	0.064	0.032
0	0.212	0.031	0.223
	0.102	0.027	0.108
-14	0.061	0.026	0.064
-20	0.022	0.212	0.219
	0.022	0.102	0.109
-70	0.022	0.061	0.069
	-70	-20	-14
		0	+6
			+23

Power level in dBm

0 °C to +50 °C
+15 °C to +35 °C
+20 °C to +25 °C

> 18 GHz to 26.5 GHz

+23	0.242	0.254	0.049
	0.134	0.139	0.049
+6	0.098	0.099	0.049
0	0.231	0.038	0.254
	0.119	0.034	0.139
-14	0.079	0.032	0.099
-20	0.022	0.231	0.242
	0.022	0.119	0.134
-70	0.022	0.079	0.098
	-70	-20	-14
		0	+6
			+23

Power level in dBm

> 26.5 GHz to 33 GHz

+23	0.268	0.288	0.067
	0.162	0.174	0.067
+6	0.129	0.136	0.067
0	0.252	0.047	0.288
	0.137	0.042	0.174
-14	0.096	0.040	0.136
-20	0.023	0.252	0.268
	0.023	0.137	0.162
-70	0.023	0.096	0.129
	-70	-20	-14
		0	+6
			+23

Power level in dBm

0 °C to +50 °C
+15 °C to +35 °C
+20 °C to +25 °C

R&S®NRP40S(N)/50S(N) multipath power sensors

Specifications from 50 MHz to 40 GHz apply to the R&S®NRP40S(N).

Specifications from 50 MHz to 50 GHz apply to the R&S®NRP50S(N).

Frequency range	R&S®NRP40S(N)	50 MHz to 40 GHz	
	R&S®NRP50S(N)	50 MHz to 50 GHz	
Impedance matching (SWR)	50 MHz to 2.4 GHz	< 1.13 (1.11)	(): +15 °C to +35 °C
	> 2.4 GHz to 8.0 GHz	< 1.20 (1.18)	
	> 8.0 GHz to 18.0 GHz	< 1.25 (1.23)	
	> 18.0 GHz to 26.5 GHz	< 1.30 (1.28)	
	> 26.5 GHz to 33.0 GHz	< 1.35 (1.33)	
	> 33.0 GHz to 40.0 GHz	< 1.37 (1.35)	
	> 40.0 GHz to 50.0 GHz	< 1.40 (1.38)	
Power measurement range	continuous average	100 pW to 100 mW (–70 dBm to +20 dBm)	
	burst average	300 nW to 100 mW (–35 dBm to +20 dBm)	
	timeslot/gate average	300 pW to 100 mW (–65 dBm to +20 dBm) ¹	
	trace	2 nW to 100 mW (–57 dBm to +20 dBm) ²	
Max. power	average power	0.2 W (+23 dBm) AVG, max. 10 V DC	
	peak envelope power	1 W (+30 dBm) for max. 10 µs	
Measurement subranges	path 1	–70 dBm to –15 dBm	
	path 2	–53 dBm to +5 dBm	
	path 3	–33 dBm to +20 dBm	
Transition regions	with automatic path selection ³	(–20 ± 1) dBm to (–14 ± 1) dBm (0 ± 1) dBm to (+6 ± 1) dBm	
Dynamic response	video bandwidth	> 100 kHz (150 kHz)	(): +15 °C to +35 °C
	rise time 10 %/90 %	< 5 µs (3 µs)	
Acquisition	sample rate (continuous)	2 Msps	
Triggering	internal		
	threshold level range	–38 dBm to +20 dBm	
	threshold level accuracy	identical to uncertainty for absolute power measurements	
	threshold level hysteresis	0 dB to 10 dB	
	dropout ⁴	0 s to 10 s	
	external	EXTernal[1]: R&S®NRP2 or R&S®NRP-Z5 EXTernal2: coaxial trigger I/O	
	slope (external, internal)	pos./neg.	
	delay	–5 s to +10 s	
	hold-off	0 s to 10 s	
	resolution (delay, hold-off, dropout)	0.5 µs (sample period)	
	source	INTernal, EXTernal[1], EXTernal2, IMMEDIATE, BUS, HOLD	
	Zero offset	initial, without zeroing	
path 1		< 280 [235] (50) pW	
path 2		< 26.3 [22.0] (4.8) nW	
path 3		< 1.34 [1.06] (0.23) µW	
after external zeroing ⁵			
path 1		< 58 [49] (28) pW	
path 2		< 5.5 [4.6] (2.7) nW	
path 3	< 280 [220] (130) nW		
Zero drift ⁶	path 1	< 14 [12] (2) pW	
	path 2	< 1.3 [1.1] (0.2) nW	
	path 3	< 67 [53] (9) nW	
Measurement noise ⁷	path 1	< 41 [35] (20) pW	
	path 2	< 3.9 [3.3] (1.9) nW	
	path 3	< 196 [155] (90) nW	

Uncertainty for absolute power measurements ⁸ in dB

50 MHz to < 200 MHz

0.241	0.196	0.193
0.113	0.098	0.099
0.077	0.073	0.077

-70 -20 0 +20
Power level in dBm

200 MHz to 8 GHz

0.162	0.172	0.171
0.095	0.094	0.097
0.081	0.074	0.078

-70 -20 0 +20
Power level in dBm

0 °C to +50 °C
+15 °C to +35 °C
+20 °C to +25 °C

> 8 GHz to 12.4 GHz

0.152	0.157	0.157
0.103	0.098	0.101
0.090	0.081	0.086

-70 -20 0 +20
Power level in dBm

> 12.4 GHz to 18 GHz

0.165	0.167	0.168
0.117	0.111	0.114
0.104	0.095	0.100

-70 -20 0 +20
Power level in dBm

0 °C to +50 °C
+15 °C to +35 °C
+20 °C to +25 °C

> 18 GHz to 26.5 GHz

0.176	0.176	0.180
0.122	0.114	0.120
0.107	0.095	0.103

-70 -20 0 +20
Power level in dBm

> 26.5 GHz to 33 GHz

0.196	0.196	0.203
0.139	0.131	0.140
0.123	0.111	0.122

-70 -20 0 +20
Power level in dBm

0 °C to +50 °C
+15 °C to +35 °C
+20 °C to +25 °C

> 33 GHz to 40 GHz

0.216	0.217	0.229
0.152	0.145	0.159
0.134	0.122	0.138

-70 -20 0 +20
Power level in dBm

> 40 GHz to 50 GHz

0.257	0.260	0.279
0.188	0.184	0.205
0.169	0.160	0.183

-70 -20 0 +20
Power level in dBm

0 °C to +50 °C
+15 °C to +35 °C
+20 °C to +25 °C

Uncertainty for relative power measurements ⁹ in dB

50 MHz to < 200 MHz

+20	0.285	0.252	0.046
	0.127	0.117	0.045
+6	0.081	0.077	0.045
0	0.277	0.040	0.252
	0.121	0.038	0.117
-14	0.073	0.038	0.077
-20	0.028	0.277	0.285
	0.028	0.121	0.127
-70	0.028	0.073	0.081
	-70	-20	-14
		0	+6
			+20

Power level in dBm

200 MHz to < 8 GHz

+20	0.214	0.221	0.047	0 °C to +50 °C
	0.109	0.109	0.047	+15 °C to +35 °C
+6	0.083	0.077	0.047	+20 °C to +25 °C
0	0.206	0.040	0.221	0 °C to +50 °C
	0.102	0.038	0.109	+15 °C to +35 °C
-14	0.076	0.038	0.077	+20 °C to +25 °C
-20	0.029	0.206	0.214	0 °C to +50 °C
	0.029	0.102	0.109	+15 °C to +35 °C
-70	0.029	0.076	0.083	+20 °C to +25 °C
	-70	-20	-14	
		0	+6	
			+20	

Power level in dBm

> 8 GHz to 12.4 GHz

+20	0.195	0.199	0.050
	0.111	0.108	0.049
+6	0.086	0.080	0.049
0	0.187	0.041	0.199
	0.104	0.039	0.108
-14	0.079	0.039	0.080
-20	0.029	0.187	0.195
	0.029	0.104	0.111
-70	0.029	0.079	0.086
	-70	-20	-14
		0	+6
			+20

Power level in dBm

> 12.4 GHz to 18 GHz

+20	0.203	0.205	0.054	0 °C to +50 °C
	0.117	0.113	0.054	+15 °C to +35 °C
+6	0.092	0.085	0.054	+20 °C to +25 °C
0	0.194	0.043	0.205	0 °C to +50 °C
	0.109	0.041	0.113	+15 °C to +35 °C
-14	0.083	0.041	0.085	+20 °C to +25 °C
-20	0.030	0.194	0.203	0 °C to +50 °C
	0.030	0.109	0.117	+15 °C to +35 °C
-70	0.030	0.083	0.092	+20 °C to +25 °C
	-70	-20	-14	
		0	+6	
			+20	

Power level in dBm

> 18 GHz to 26.5 GHz

+20	0.226	0.227	0.064
	0.134	0.130	0.064
+6	0.106	0.099	0.064
0	0.214	0.048	0.227
	0.122	0.046	0.130
-14	0.092	0.046	0.099
-20	0.032	0.214	0.226
	0.032	0.122	0.134
-70	0.032	0.092	0.106
	-70	-20	-14
		0	+6
			+20

Power level in dBm

> 26.5 GHz to 33 GHz

+20	0.252	0.254	0.074	0 °C to +50 °C
	0.153	0.151	0.074	+15 °C to +35 °C
+6	0.122	0.117	0.074	+20 °C to +25 °C
0	0.236	0.054	0.254	0 °C to +50 °C
	0.135	0.052	0.151	+15 °C to +35 °C
-14	0.101	0.051	0.117	+20 °C to +25 °C
-20	0.034	0.236	0.252	0 °C to +50 °C
	0.034	0.135	0.153	+15 °C to +35 °C
-70	0.034	0.101	0.122	+20 °C to +25 °C
	-70	-20	-14	
		0	+6	
			+20	

Power level in dBm

> 33 GHz to 40 GHz

+20	0.285	0.289	0.088
	0.176	0.179	0.087
+6	0.141	0.142	0.087
0	0.263	0.062	0.289
	0.151	0.060	0.179
-14	0.111	0.059	0.142
-20	0.036	0.263	0.285
	0.036	0.151	0.176
-70	0.036	0.111	0.141
	-70	-20	-14
		0	+6
			+20

Power level in dBm

> 40 GHz to 50 GHz

+20	0.336	0.344	0.110	0 °C to +50 °C
	0.214	0.224	0.110	+15 °C to +35 °C
+6	0.174	0.184	0.109	+20 °C to +25 °C
0	0.304	0.077	0.344	0 °C to +50 °C
	0.174	0.074	0.224	+15 °C to +35 °C
-14	0.126	0.073	0.184	+20 °C to +25 °C
-20	0.040	0.304	0.336	0 °C to +50 °C
	0.040	0.174	0.214	+15 °C to +35 °C
-70	0.040	0.126	0.174	+20 °C to +25 °C
	-70	-20	-14	
		0	+6	
			+20	

Power level in dBm

Additional characteristics of the R&S®NRPxxS(N) multipath power sensors and the R&S®NRP33SN-V multipath power sensor for use in thermal vacuum

Sensor type		three-path diode power sensor	
Measurand		power of incident wave power of source (DUT) into 50 Ω ¹⁰	
RF connector	R&S®NRP8S(N)/18S(N)	N (male)	
	R&S®NRP33S(N)/33SN-V	3.5 mm (male)	
	R&S®NRP40S(N)	2.92 mm (male)	
	R&S®NRP50S(N)	2.4 mm (male)	
Measurement functions	stationary and recurring waveforms	continuous average	
		burst average	
		timeslot/gate average	
		trace	
Continuous average function	single events	burst average	
		timeslot/gate average	
		trace	
		measurand	mean power over recurring acquisition interval
Burst average function	measurand	aperture	10 µs to 2.0 s (20 ms default)
		window function	uniform or von Hann ¹¹
		duty cycle correction ¹²	0.001 % to 100.0 %
		capacity of measurement buffer ¹³	1 to 8192 results
		mean power over burst portion of recurring signal (trigger settings required)	
Timeslot/gate average function	measurand	detectable burst width ¹⁴	5 µs to 8 s
		minimum gap between bursts	5 µs
		dropout period ¹⁵ for burst end detection	1 µs to 300 ms
		exclusion periods ¹⁶	
		start	0 s to 1 s
		end	0 s to 1 s
		resolution (dropout and exclusion periods)	0.5 µs (sample period)
		mean power over individual timeslots/gates	
		number of timeslots/gates	1 to 32 (consecutive)
		nominal length	10 µs to 0.1 s
start of first timeslot/gate	at delayed trigger event		
Trace function	measurand	exclusion periods	
		start	0 s to 1 s
		end	0 s to 1 s
		resolution (nominal length and exclusion periods)	0.5 µs (sample period)
		mean, random, maximum and minimum power over pixel length	
		acquisition	
		length	10 µs to 3.0 s
		start (referenced to delayed trigger)	-3.0 s to 3.0 s
		result	
		pixels	1 to 8192
resolution	≥ 0.5 µs (sample period)		

Averaging filter	modes	auto off (fixed averaging number)	
		auto on (continuously auto-adapted)	
		auto once (automatically fixed once)	
	auto off		
	supported measurement functions	all	
	averaging number	1, 2, 4, 6, 8, 10 to 65536 (1 or all even numbers between 2 and 65536)	
	auto on/once		
	supported measurement functions	continuous average, burst average, timeslot/gate average	
	normal operating mode	averaging number adapted to resolution setting and power to be measured	
	fixed noise operating mode	averaging number adapted to specified noise content	
result output			
moving mode		continuous result output, independent of averaging number	
repeat mode		only final result	
Attenuation correction	function	corrects the measurement result by means of a fixed factor (dB offset)	
	range	-200.000 dB to +200.000 dB	
Embedding	function	incorporates a two-port device at the sensor input so that the measurement plane is shifted to the input of this device	
	parameters	S_{11} , S_{21} , S_{12} and S_{22} of device	
	number of devices	0 to 999	
	total number of frequencies	≤ 80000	
Gamma correction	function	removes the influence of impedance mismatch from the measurement result so that the measurand corresponds to the power of the source (DUT) into 50 Ω	
	parameters	magnitude and phase of reflection coefficient of source (DUT)	
Frequency response correction	function	takes the frequency response of the sensor section and of the RF power attenuator into account (if applicable)	
	parameter	center frequency of test signal	
	residual uncertainty	see specification of calibration uncertainty and uncertainty for absolute and relative power measurements	
Measurement times ¹⁷ Av: averaging number	continuous average		
	single measurements	$2 \times (\text{aperture} + 100 \mu\text{s}) \times Av + t_z$	
	buffered measurements without averaging	$2 \times (\text{aperture} + 116 \mu\text{s}) \times \text{buffer size} + t_z$ $t_z = 2 \text{ ms (typ.)}$	
Zeroing (duration)		5.3 s	
Measurement error due to modulation ¹⁸	general	depends on CCDF and RF bandwidth of test signal	
	WCDMA (3GPP test model 1-64)		
	worst case	-0.02 dB to +0.05 dB	
	typical	-0.01 dB to +0.03 dB	
	E-UTRA test model 1.1 (E-TM1.1), 20 MHz		
	worst case	-0.03 dB to +0.08 dB	
	typical	-0.02 dB to +0.05 dB	
Change of input reflection coefficient with respect to power ¹⁹	R&S®NRP8S(N)/18S(N)/33S(N)/33SN-V		
	10 MHz to 2.4 GHz	< 0.02 (0.01)	(): +15 °C to +35 °C
	> 2.4 GHz	< 0.03 (0.02)	
	R&S®NRP40S(N)/50S(N)		
	50 MHz to 8.0 GHz	< 0.04 (0.02)	(): levels ≤ 10 dBm
	> 8.0 GHz to 18.0 GHz	< 0.06 (0.03)	
	> 18.0 GHz to 33.0 GHz	< 0.07 (0.04)	
	> 33.0 GHz to 50.0 GHz	< 0.09 (0.05)	

Calibration uncertainty ²⁰	R&S®NRP8S(N)/18S(N)/33S(N)/33SN-V	path 1	path 2	path 3
	10 MHz to < 100 MHz	0.058 dB	0.052 dB	0.053 dB
	100 MHz to 2.40 GHz	0.060 dB	0.058 dB	0.058 dB
	> 2.4 GHz to 8.0 GHz	0.065 dB	0.062 dB	0.063 dB
	> 8.0 GHz to 12.4 GHz	0.075 dB	0.071 dB	0.072 dB
	> 12.4 GHz to 18.0 GHz	0.092 dB	0.088 dB	0.089 dB
	> 18.0 GHz to 26.5 GHz	0.093 dB	0.089 dB	0.090 dB
	> 26.5 GHz to 33.0 GHz	0.113 dB	0.108 dB	0.109 dB
	R&S®NRP40S(N)/50S(N)	path 1	path 2	path 3
	50 MHz to < 200 MHz	0.076 dB	0.070 dB	0.071 dB
	200 MHz to 8.0 GHz	0.080 dB	0.071 dB	0.072 dB
	> 8.0 GHz to 12.4 GHz	0.089 dB	0.079 dB	0.080 dB
	> 12.4 GHz to 18.0 GHz	0.104 dB	0.093 dB	0.094 dB
	> 18.0 GHz to 26.5 GHz	0.107 dB	0.092 dB	0.093 dB
	> 26.5 GHz to 33.0 GHz	0.123 dB	0.107 dB	0.108 dB
	> 33.0 GHz to 40.0 GHz	0.133 dB	0.115 dB	0.117 dB
	> 40.0 GHz to 50.0 GHz	0.168 dB	0.150 dB	0.152 dB
	Host interface	mechanical	8-pin male M12 connector (A-coded)	
power supply		+5 V/0.5 A (USB high-power device)		
speed		supports high-speed and full-speed modes according to the specification		
remote control protocols		supports USB test and measurement device class (USBTMC) and legacy mode for compatibility with R&S®NRP-Zxx power sensors		
trigger input EXTERNAL[1]		differential (0 V/+3.3 V)		
reference clock				
signal level		LVDS		
frequency		20 MHz		
permissible total cable length		≤ 5 m		
Ethernet interface only for R&S®NRPxxSN types and the R&S®NRP33SN-V	mechanical	RJ-45 jack		
	power supply	power over Ethernet (PoE) class 1 device		
	speed	10/100/1000 Mbit/s		
	remote control protocols	VXI11, HiSLIP (high-speed LAN instrument protocol), SCPI-RAW (port 5025)		
	permissible cable length	≤ 100 m		
Trigger-I/O EXTERNAL2	mechanical	SMB built-in jack		
	impedance			
	input	10 kΩ or 50 Ω		
	output	50 Ω		
	signal level			
	output	compatible with 3 V or 5 V logic, max. -1 to +6 V ≥ 2 V into 50 Ω load, max. 5.3 V		
Vacuum-specific characteristics of the R&S®NRP33SN-V	recommended bake-out procedure	vacuum bake for 100 h at +85 °C and P < 10 ⁻⁵ mbar		
	typical mass loss during bake-out	70 mg		
Mounting of R&S®NRP33SN-V onto a baseplate for technical drawings see Appendix	general data	Two threaded through-holes are provided for mounting the sensor to a baseplate. Using a low-outgassing thermal interface material such as graphite foil is highly recommended.		
	distance between mounting holes	2" (50.8 mm)		
	thread standard	UNC 8-32		
	thread length	¼ " (6.35 mm)		
Dimensions (W × H × L)	R&S®NRPxxS	48 mm × 30 mm × 138 mm (1.89 in × 1.18 in × 5.43 in)		
	R&S®NRPxxSN, R&S®NRP33SN-V	73 mm × 26 mm × 146 mm (2.87 in × 1.02 in × 5.75 in)		
Weight	R&S®NRPxxS	< 0.20 kg (0.44 lb)		
	R&S®NRPxxSN, R&S®NRP33SN-V	< 0.35 kg (0.77 lb)		

Accessories for R&S®NRP power sensors

Accessories are not approved for the usage in thermal vacuum chambers.

R&S®NRP-ZKU interface cables

The R&S®NRP-ZKU interface cables are used to connect Rohde & Schwarz power sensors described in this data sheet to any standard-conforming USB downstream port (type A receptacle), e.g. on a PC, USB hub or a Rohde & Schwarz instrument.

Connectors	sensor side	8-pin female M12 connector (A-coded)
	host side	USB type A plug
Length	model .02	0.75 m
	model .03	1.50 m
	model .04	3.00 m
	model .05	5.00 m

The R&S®NRP-ZKU interface cables must not be combined with passive USB extension cables as well as commercially available M12 extension cables. Using such extension cables can affect the reliability of the high-speed data transfer.

R&S®NRP-ZK6 interface cables

The R&S®NRP-ZK6 interface cables are used to connect Rohde & Schwarz power sensors described in this data sheet to an R&S®NRP2 power meter, R&S®NRP-Z5 sensor hub or a Rohde & Schwarz instrument providing a 6-pole circular receptacle for R&S®NRP power sensors.

Connectors	sensor side	8-pin female M12 connector (A-coded)
	host side	6-pole circular plug with push-pull locking
Length	model .02	1.50 m
	model .03	3.00 m
	model .04	5.00 m

The R&S®NRP-ZK6 interface cables must not be combined with the R&S®NRP-Z2/-Z3/-Z4 cables as well as commercially available M12 extension cables. Using such extension or adapter cables can affect the reliability of the high-speed data transfer.

R&S®NRP-ZAP1 Gigabit Ethernet switch with Power-over-Ethernet (PoE) capability

The R&S®NRP-ZAP1 Gigabit Ethernet switch with Power-over-Ethernet (PoE) capability can be used to connect up to four R&S®NRPxxSN power sensors to a local area network (LAN) and provide them with operating power.

OEM manufacturer and type		Zyxel GS1110-8HP	
Connectivity	LAN ports (PoE)	4 Ethernet RJ-45 ports with PoE power sourcing capability (up to 30 W per port, up to 75 W overall power budget)	
	LAN ports (non-PoE)	4 Ethernet RJ-45 ports	
	standard conformance		IEEE 802.3 10BASE-T Ethernet
			IEEE 802.3u 100BASE-TX Ethernet
			IEEE 802.3ab 1000BASE-T Ethernet
		IEEE 802.3af PoE	
		IEEE 802.3at PoE+	
Power consumption		≤ 90 W	
Dimensions (W × D × H)	switch	210 mm × 104 mm × 27 mm (8.27 in × 4.09 in × 1.06 in)	
Weight	switch	0.55 kg (1.20 lb)	
	external power supply and power cord	0.60 kg (1.30 lb)	
	switch including power supply, power cord and packing	1.47 kg (3.20 lb)	
Environmental specifications	operating temperature range	0 °C to +50 °C	
	storage temperature range	−40 °C to +70 °C	
	operation humidity range	10 % to 95 % relative humidity, noncondensing	

General data

Specifications do not apply to the R&S®NRP-ZAP1 Gigabit Ethernet switch.

Temperature ²¹	R&S®NRPxxS(N), R&S®NRP-ZKx	
	operating temperature range	0 °C to +50 °C
	permissible temperature range	-10 °C to +55 °C
	storage temperature range	-40 °C to +85 °C
	R&S®NRP33SN-V	
	operating temperature range	0 °C to +50 °C
Climatic resistance	damp heat	+25 °C/+55 °C cyclic at 95 % relative humidity with restrictions: noncondensing, in line with EN 60068-2-30
	Mechanical resistance	
	vibration	
	sinusoidal	5 Hz to 55 Hz, 0.15 mm amplitude, 1.8 g at 55 Hz, 55 Hz to 150 Hz, 0.5 g constant, in line with EN 60068-2-6
	random	10 Hz to 300 Hz, 1.9 g (RMS), in line with EN 60068-2-64
	shock	45 Hz to 2 kHz, max. 40 g shock spectrum, in line with MIL-STD-810E, method 516.4, procedure I
Air pressure	R&S®NRPxxS(N), R&S®NRP-ZK6, R&S®NRP-ZKU	
	operating	795 hPa (2000 m) to 1060 hPa
	transport	566 hPa (4500 m) to 1060 hPa
	R&S®NRP33SN-V	
	operating ²²	0 hPa to 1060 hPa
	transport	0 hPa to 1060 hPa
Electromagnetic compatibility		applied harmonized standards: EN 61326-1 EN 61326-2-1 EN 55011 (class B)
Calibration interval	recommended	2 years

Appendix

Reading the uncertainty of multipath power sensors for relative power measurements

The example shows a level step of approx. 14 dB (-4 dBm → +10 dBm) at 1.9 GHz and an ambient temperature of +28 °C for an R&S®NRP8S power sensor. The expanded uncertainty for relative power measurements in this example is 0.093 dB.

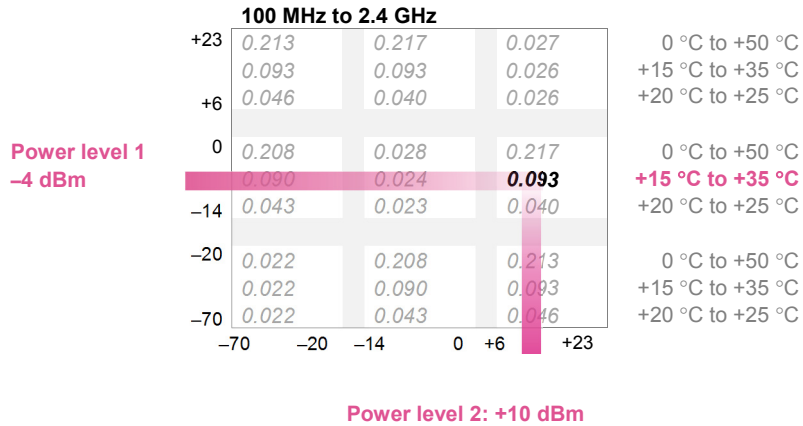

Technical drawings of the R&S®NRP33SN-V multipath power sensor for use in thermal vacuum

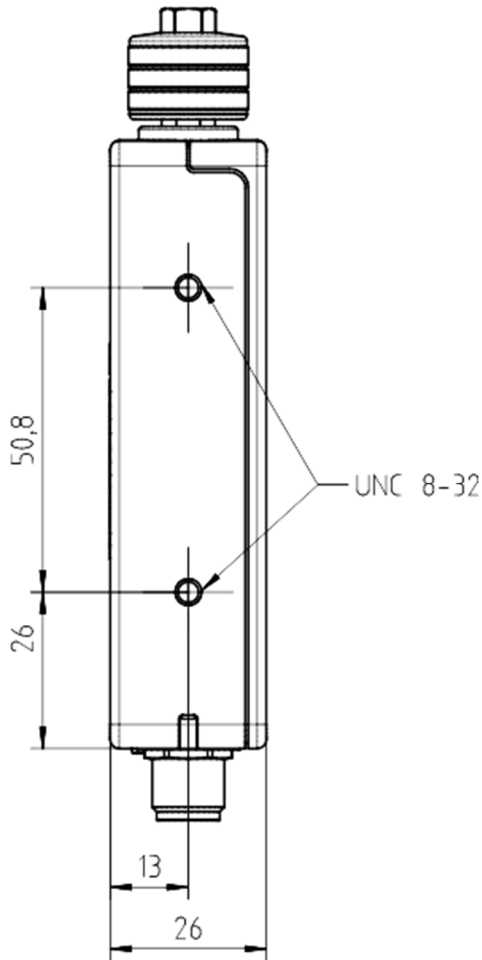
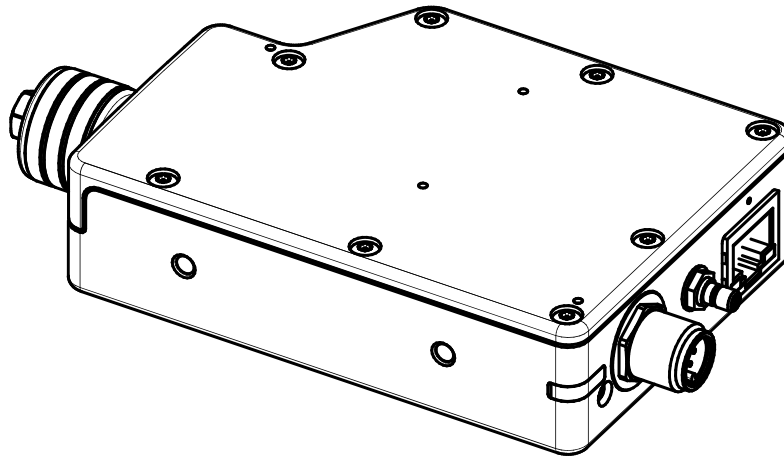

Dimensions in mm

Ordering information

Designation	Type	Order No.
Three-Path Diode Power Sensor		
100 pW to 200 mW, 10 MHz to 8 GHz	R&S®NRP8S	1419.0006.02
100 pW to 200 mW, 10 MHz to 8 GHz, LAN version	R&S®NRP8SN	1419.0012.02
100 pW to 200 mW, 10 MHz to 18 GHz	R&S®NRP18S	1419.0029.02
100 pW to 200 mW, 10 MHz to 18 GHz, LAN version	R&S®NRP18SN	1419.0035.02
100 pW to 200 mW, 10 MHz to 33 GHz	R&S®NRP33S	1419.0064.02
100 pW to 200 mW, 10 MHz to 33 GHz, LAN version	R&S®NRP33SN	1419.0070.02
100 pW to 100 mW, 50 MHz to 40 GHz	R&S®NRP40S	1419.0041.02
100 pW to 100 mW, 50 MHz to 40 GHz, LAN version	R&S®NRP40SN	1419.0058.02
100 pW to 100 mW, 50 MHz to 50 GHz	R&S®NRP50S	1419.0087.02
100 pW to 100 mW, 50 MHz to 50 GHz, LAN version	R&S®NRP50SN	1419.0093.02
100 pW to 200 mW, 10 MHz to 33 GHz, LAN version, TVAC-compliant	R&S®NRP33SN-V	1419.0129.02
Accessories (cables, additional equipment, etc.)		
USB Interface Cable, length: 0.75 m	R&S®NRP-ZKU	1419.0658.02
USB Interface Cable, length: 1.50 m	R&S®NRP-ZKU	1419.0658.03
USB Interface Cable, length: 3.00 m	R&S®NRP-ZKU	1419.0658.04
USB Interface Cable, length: 5.00 m	R&S®NRP-ZKU	1419.0658.05
Six-Pole Interface Cable, length: 1.50 m	R&S®NRP-ZK6	1419.0664.02
Six-Pole Interface Cable, length: 3.00 m	R&S®NRP-ZK6	1419.0664.03
Six-Pole Interface Cable, length: 5.00 m	R&S®NRP-ZK6	1419.0664.04
Sensor Hub	R&S®NRP-Z5	1146.7740.02
Power over Ethernet (PoE) Switch	R&S®NRP-ZAP1	1419.0829.00
Accredited Calibration, for R&S®NRPxxS/SN power sensors	R&S®NRP-ACA	1419.0812.00

Service options		
Extended Warranty, one year	R&S®WE1	Please contact your local Rohde & Schwarz sales office.
Extended Warranty, two years	R&S®WE2	
Extended Warranty, three years	R&S®WE3	
Extended Warranty, four years	R&S®WE4	
Extended Warranty with Calibration Coverage, one year	R&S®CW1	
Extended Warranty with Calibration Coverage, two years	R&S®CW2	
Extended Warranty with Calibration Coverage, three years	R&S®CW3	
Extended Warranty with Calibration Coverage, four years	R&S®CW4	

Extended warranty with a term of one to four years (WE1 to WE4)

Repairs carried out during the contract term are free of charge ²³. Necessary calibration and adjustments carried out during repairs are also covered. Simply contact the forwarding agent we name; your product will be picked up free of charge and returned to you in top condition a couple of days later.

Extended warranty with calibration (CW1 to CW4)

Enhance your extended warranty by adding calibration coverage at a package price. This package ensures that your Rohde & Schwarz product is regularly calibrated, inspected and maintained during the term of the contract. It includes all repairs ²³ and calibration at the recommended intervals as well as any calibration carried out during repairs or option upgrades.

For product brochure, see PD 3607.0852.12 and www.rohde-schwarz.com

Footnotes

- ¹ Specifications apply to timeslots/gates with a duration of 12.5 % referenced to the signal period (duty cycle 1:8). For other waveforms, the following equation applies: lower measurement limit = lower measurement limit for continuous average mode / $\sqrt{\text{duty cycle}}$.
- ² With a resolution of 256 pixels.
- ³ Specifications apply to the default transition setting of 0 dB. The transition regions can be shifted by as much as –20 dB using an adequate offset.
- ⁴ Time span prior to triggering, where the trigger signal must be entirely below the threshold level in the case of a positive slope and vice versa in the case of a negative slope.
- ⁵ Specifications expressed as an expanded uncertainty with a confidence level of 95 % (two standard deviations). For calculating zero offsets at higher confidence levels, use the properties of the normal distribution (e.g. 99.7 % confidence level for three standard deviations).
- ⁶ Within one hour after zeroing, permissible temperature change ± 1 °C, following a two-hour warm-up of the power sensor.
- ⁷ Two standard deviations at 10.24 s integration time in continuous average mode, with aperture time set to default value. The integration time is defined as the total time used for signal acquisition, i.e. the product of twice the aperture time and the averaging number. Multiplying the noise specifications by $\sqrt{(10.24 \text{ s}/\text{integration time})}$ yields the noise contribution at other integration times. Using a von Hann window function increases noise by a factor of 1.22.
- ⁸ Expanded uncertainty ($k = 2$) for absolute power measurements on CW signals with automatic path selection and the default transition setting of 0 dB. Specifications include calibration uncertainty, linearity and temperature effect. Zero offset, zero drift and measurement noise must additionally be taken into account when measuring low powers. As a rule of thumb, the contribution of zero offset can be neglected for power levels above –40 dBm. The contribution of measurement noise depends on power and integration time and can be neglected below 0.01 dB.

Example: The uncertainty of a power measurement at 3.2 nW (–55 dBm) and 1.9 GHz is to be determined for an R&S®NRP8S. The ambient temperature is +29 °C and the averaging number is set to 32 in the continuous average mode with an aperture time of 20 ms.

Since path 1 is used for the measurement, the typical absolute uncertainty due to zero offset is 28 pW (typical) after external zeroing, which corresponds to a relative measurement uncertainty of

$$10 \lg \frac{3.2 \text{ nW} + 28 \text{ pW}}{3.2 \text{ nW}} \text{ dB} = 0.038 \text{ dB.}$$

Using the formula in footnote 7, the absolute noise contribution of path 1 is typically $20 \text{ pW} \times \sqrt{(10.24 \text{ s}/(32 \times 2 \times 0.02 \text{ s}))} = 56.6 \text{ pW}$, which corresponds to a relative measurement uncertainty of

$$10 \lg \frac{3.2 \text{ nW} + 56.6 \text{ pW}}{3.2 \text{ nW}} \text{ dB} = 0.076 \text{ dB.}$$

Combined with the uncertainty of 0.088 dB for absolute power measurements under the given conditions, the total expanded uncertainty is

$$\sqrt{0.038^2 + 0.076^2 + 0.088^2} \text{ dB} = 0.122 \text{ dB.}$$

The contribution of zero drift has been neglected in this case. It must be treated like zero offset if it is relevant for total uncertainty.

- ⁹ Expanded uncertainty ($k = 2$) for relative power measurements on CW signals of the same frequency with automatic path selection and a default transition setting of 0 dB. For reading the measurement uncertainty diagrams of universal, average and level control sensors, see the Appendix.

Specifications include calibration uncertainty (only if different paths are affected), linearity and temperature effect. Zero offset, zero drift and measurement noise must additionally be taken into account when measuring low powers. As a rule of thumb, the contribution of zero offset can be neglected for power levels above –40 dBm. The contribution of measurement noise depends on power and integration time and can be neglected below 0.01 dB.

Example: The uncertainty of a power step from 0.5 mW (–3 dBm) to 10 nW (–50 dBm) at 5.4 GHz is to be determined for an R&S®NRP8S. The ambient temperature is +20 °C and the averaging number is set to 16 for both measurements in the continuous average mode with an aperture time of 20 ms. For the calculation of total uncertainty, the relative contribution of noise, zero offset and zero drift must be taken into account for both measurements. In this example, all contributions at –3 dBm and the effect of zero drift at –50 dBm have been neglected.

Since path 1 is used for the –50 dBm measurement, the typical absolute uncertainty due to zero offset is 28 pW after external zeroing, which corresponds to a relative measurement uncertainty of

$$10 \lg \frac{10 \text{ nW} + 28 \text{ pW}}{10 \text{ nW}} \text{ dB} = 0.012 \text{ dB.}$$

Using the formula in footnote 7, the absolute noise contribution of path 1 is typically $20 \text{ pW} \times \sqrt{(10.24 \text{ s}/(16 \times 2 \times 0.02 \text{ s}))} = 80 \text{ pW}$, which corresponds to a relative measurement uncertainty of

$$10 \lg \frac{10 \text{ nW} + 80 \text{ pW}}{10 \text{ nW}} \text{ dB} = 0.035 \text{ dB.}$$

Combined with the uncertainty of 0.050 dB for relative power measurements under the given conditions, the total expanded uncertainty is

$$\sqrt{0.012^2 + 0.035^2 + 0.050^2} \text{ dB} = 0.062 \text{ dB.}$$

- ¹⁰ Gamma correction activated.
- ¹¹ Preferably used with determined modulation when the aperture time cannot be matched to the modulation period. Compared to a uniform window, measurement noise is about 22 % higher.
- ¹² For measuring the power of periodic bursts based on an average power measurement.
- ¹³ To increase measurement speed, the power sensor can be operated in buffered mode. In this mode, measurement results are stored in a buffer of user-definable size and then output as a block of data when the buffer is full. To enhance measurement speed even further, the sensor can be set to record the entire series of measurements when triggered by a single event. In this case, the power sensor automatically starts a new measurement as soon as it has completed the previous one.
- ¹⁴ For moving mode the maximum burst width of a single burst is 8 s. For repeat mode the mean burst length is limited to 8 s/averaging number.

-
- ¹⁵ This parameter enables power measurements on modulated bursts. The parameter must be longer in duration than modulation-induced power drops within the burst.
- ¹⁶ To exclude unwanted portions of the signal from the measurement result.
- ¹⁷ Specifications are valid for repeat mode, extending from the beginning to the end of all transfers. The actual values depend on the host system, therefore typical values are specified. They have been measured with a USB connection including one USB hub using the USBTMC protocol and an Ethernet network including one PoE switch using the HiSLIP protocol. Measurement times under remote control of the R&S®NRP2 base unit via IEC/IEEE bus are approximately 2.5 ms longer, extending from the start of the measurement up to when the measurement result has been supplied to the output buffer of the R&S®NRP2.
- ¹⁸ Measurement error referenced to a CW signal of equal power and frequency. Specifications apply up to +20 dBm for automatic path selection or within a subrange to the maximum level of the subrange minus 3 dB.
- ¹⁹ Change of the reflection coefficient (error vector magnitude) referenced to 0 dBm.
- ²⁰ Expanded uncertainty ($k = 2$) for absolute power measurements on CW signals at the calibration level within a temperature range from +20 °C to +25 °C and at the calibration frequencies. Specifications include zero offset and measurement noise (up to a 2σ value of 0.004 dB). The calibration level is -20 dBm for path 1 and 0 dBm for paths 2 and 3.
- ²¹ The operating temperature range defines the span of ambient temperature in which the instrument complies with specifications. In the permissible temperature range, the instrument is still functioning but compliance with specifications is not warranted.
- ²² To operate the R&S®NRP33SN-V at an air pressure below 795 hPa the sensor has to be mounted onto a temperature-controlled baseplate. In this case the temperature of the baseplate is regarded as the ambient temperature of the sensor.
- ²³ Excluding defects caused by incorrect operation or handling and force majeure. Wear-and-tear parts are not included.

Service that adds value

- | Worldwide
- | Local and personalized
- | Customized and flexible
- | Uncompromising quality
- | Long-term dependability

About Rohde & Schwarz

The Rohde & Schwarz electronics group offers innovative solutions in the following business fields: test and measurement, broadcast and media, secure communications, cybersecurity, radiomonitoring and radiolocation. Founded more than 80 years ago, this independent company has an extensive sales and service network and is present in more than 70 countries. The electronics group is among the world market leaders in its established business fields. The company is headquartered in Munich, Germany. It also has regional headquarters in Singapore and Columbia, Maryland, USA, to manage its operations in these regions.

Sustainable product design

- | Environmental compatibility and eco-footprint
- | Energy efficiency and low emissions
- | Longevity and optimized total cost of ownership

Certified Quality Management

ISO 9001

Certified Environmental Management

ISO 14001

Rohde & Schwarz GmbH & Co. KG

www.rohde-schwarz.com

Rohde & Schwarz training

www.training.rohde-schwarz.com

Regional contact

- | Europe, Africa, Middle East | +49 89 4129 12345
customersupport@rohde-schwarz.com
- | North America | 1 888 TEST RSA (1 888 837 87 72)
customer.support@rsa.rohde-schwarz.com
- | Latin America | +1 410 910 79 88
customersupport.la@rohde-schwarz.com
- | Asia Pacific | +65 65 13 04 88
customersupport.asia@rohde-schwarz.com
- | China | +86 800 810 82 28 | +86 400 650 58 96
customersupport.china@rohde-schwarz.com

R&S® is a registered trademark of Rohde & Schwarz GmbH & Co. KG

Trade names are trademarks of the owners

PD 3607.0852.22 | Version 02.00 | December 2015 (sk)

R&S®NRP USB and LAN Power Sensors

Data without tolerance limits is not binding | Subject to change

© 2014 - 2015 Rohde & Schwarz GmbH & Co. KG | 81671 Munich, Germany



3607085222