PXle-5114

Specifications

2025-10-14



Contents

PXIe-5114 Specifications 3

PXIe-5114 Specifications

Definitions

Warranted specifications describe the performance of a model under stated operating conditions and are covered by the model warranty. Warranted specifications account for measurement uncertainties, temperature drift, and aging. Warranted specifications are ensured by design or verified during production and calibration.

Characteristics describe values that are relevant to the use of the model under stated operating conditions but are not covered by the model warranty.

- **Typical** specifications describe the performance met by a majority of models.
- **Nominal** specifications describe an attribute that is based on design, conformance testing, or supplemental testing.
- **Measured** specifications describe the measured performance of a representative model.

Specifications are **Typical** unless otherwise noted.

Conditions

Specifications are valid under the following conditions unless otherwise noted.

- All filter settings
- All impedance selections
- Sample clock set to 250 MS/s

Warranted specifications are valid under the following conditions unless otherwise noted.

- Temperature range of 0 °C to 55 °C
- The PXIe-5114 is warmed up for 15 minutes at ambient temperature
- Self-calibration is completed after warm-up period
- Calibration cycle is maintained

- The PXI Express chassis fan speed is set to HIGH, the foam fan filters are removed if present, and the empty slots contain PXI chassis slot blockers and filler panels. For more information about cooling, refer to the **Maintain Forced-Air Cooling Note to Users** available at ni.com/manuals.
- External calibration is performed at $23\text{ }^{\circ}\text{C} \pm 3\text{ }^{\circ}\text{C}$

PXIe-5114 Pinout

Use the pinout to connect to terminals on the PXIe-5114.

Figure 1. PXIe-5114 Connector Pinout

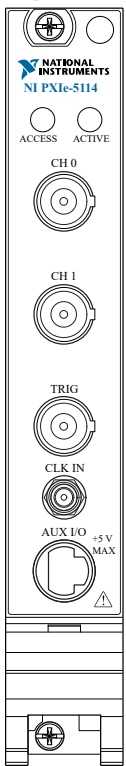

Table 1. Signal Descriptions

| Connector | Description | Function |
|------------|------------------------|--|
| CH 0, CH 1 | Standard BNC connector | Analog input connection; digitizes data and triggers acquisitions. |
| TRIG | Standard BNC connector | External analog trigger connection; signals on the TRIG connector cannot be digitized. |

| Connector | Description | Function |
|-----------|-----------------------------------|---|
| CLK IN | SMB jack | Imports an external reference or sample clock to the digitizer. |
| AUX I/O | 9-pin mini-circular DIN connector | Provides access to the external digital trigger lines, PFI 0 and PFI 1 (with optional cable). |

Vertical

Analog Input

| | |
|--------------------|------------------------------|
| Number of channels | Two (simultaneously sampled) |
| Input type | Referenced single-ended |
| Connectors | BNC |

Impedance and Coupling

| Input impedance | |
|-----------------|--|
| 50 Ω | 50 $\Omega \pm 1.5\%$ |
| 1 M Ω | 1 M $\Omega \pm 1\%$ in parallel with a nominal capacitance of 26 pF |
| Input coupling | AC ¹ , DC, GND |

1. AC coupling available on 1 M Ω input only.

Voltage Levels

Table 2. Full-Scale (FS) Input Range and Programmable Vertical Offset Range

| Input Range (V _{pk-pk}) | Vertical Offset Range (V) | |
|-----------------------------------|---------------------------|------------|
| | 50 Ω Input | 1 MΩ Input |
| 0.04 V | ±0.8 | ±0.8 |
| 0.1 V | | |
| 0.2 V | | |
| 0.4 V | | |
| 1 V | ±6.5 | ±8.0 |
| 2 V | ±6.0 | |
| 4 V | ±5.0 | |
| 10 V | ±2.0 | ±30 |
| 20 V | — | ±25 |
| 40 V | — | ±15 |

| Maximum input overload | |
|------------------------|----------------------------|
| 50 Ω | 7 V RMS with Peaks ≤10 V |
| 1 MΩ | Peaks ≤35 V |

Accuracy

| | |
|--------------------------|--|
| Resolution | 8 bits |
| DC accuracy ² | $\pm[(1.5\% \times \mathbf{Reading} - \mathbf{Vertical\ Offset} + 2\% \text{ of } \mathbf{Vertical\ Offset} + 0.3\% \text{ of } \mathbf{FS} + 200 \mu\text{V})]$, warranted |

2. Within ±5 °C of self-calibration temperature.

| | | |
|------------------------------|---|--|
| DC drift | $\pm(0.03\% \times \textit{Reading} + 0.06\% \text{ of } \textit{FS} + 40 \mu\text{V})$ per °C, nominal | |
| Crosstalk³ | | |
| At 10 MHz input frequency | ≤ -60 dB | |
| At 100 MHz input frequency | ≤ -45 dB | |

Bandwidth and Transient Response

| | | |
|---|------------------------------------|--|
| Bandwidth (-3 dB) | | |
| 0.04 V _{pk-pk} input range | 100 MHz, warranted | |
| All other input ranges | 125 MHz, warranted | |
| Rise/fall time | | |
| 0.04 V _{pk-pk} input range | 3.5 ns | |
| All other input ranges | 2.8 ns | |
| Bandwidth-limiting filter | 20 MHz noise filter | |
| AC coupling ⁴ cutoff (-3 dB) | 12 Hz | |
| Passband flatness ⁵ | ± 1 dB up to 50 MHz, warranted | |

3. CH 0 to/from CH 1, and External Trigger to CH 0 or CH 1

4. AC coupling available on 1 M Ω input only.

Figure 2. PXle-5114 Frequency Response, Measured

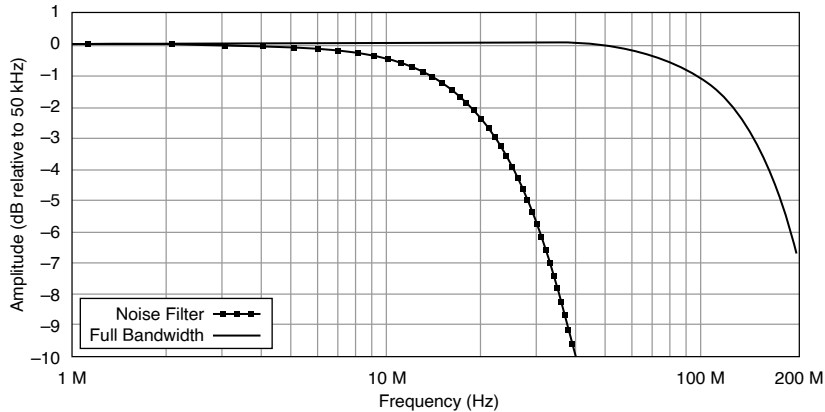

Spectral Characteristics

| | |
|--|---------|
| Spurious-free dynamic range (SFDR) ^{6[6]} | 58 dBc |
| Total harmonic distortion (THD) ^[6] | -58 dBc |
| Effective number of bits (ENOB), calculated^[6] | |
| 0.04 V _{pk-pk} input range | 6.2 |
| All other input ranges | 7.2 |
| Signal to noise and distortion (SINAD)^[6] | |
| 0.04 V _{pk-pk} input range | 38 dB |
| All other input ranges | 44 dB |

5. Referenced to 50 kHz, with bandwidth-limiting filter disabled.
6. 10 MHz, 10 MHz - 1 dBFS input signal. Includes the second through the fifth harmonics. Measured from DC to 125 MHz, with the 20 MHz bandwidth-limiting filter disabled. ENOB values are corrected to full scale.

Noise

Table 3. RMS Noise⁷

| Input Range (V _{pk-pk}) | Full Bandwidth | 20 MHz Filter Enabled |
|-----------------------------------|----------------|-----------------------|
| 0.04 V | 0.45% FS | 0.28% FS |
| All other input ranges | 0.28% FS | 0.28% FS |

Horizontal

Sample Clock

| Sources | |
|-----------------------|------------------------------------|
| Internal ⁸ | Onboard clock (internal VCXO) |
| External | CLK IN (front panel SMB connector) |

Onboard Clock (Internal VCXO)

| Sample rate range | |
|---|---|
| Real-time sampling (single-shot) ⁹ | 3.815 kS/s to 250 MS/s |
| Random interleaved sampling (RIS) | 250 MS/s to 5 GS/s in 250 MS/s increments |
| Timebase frequency ¹⁰ | 250 MHz |
| Timebase accuracy | |

7. Verified using a 50 Ω terminator connected to input.

8. Internal Sample clock is locked to the Reference clock or derived from the onboard VCXO.

9. Divide by n sampling used for all rates less than 250 MS/s. For more information about the Sample clock and decimation, refer to the [NI High-Speed Digitizers Help](#).

10. When not using external Sample clock.

| | |
|-------------------------------------|---------------------------------------|
| Not phase-locked to Reference clock | ±25 ppm, warranted |
| Phase-locked to Reference clock | Equal to the Reference clock accuracy |
| Sample clock delay range | ±1 Sample clock period |
| Sample clock delay resolution | ≤20 ps |

External Sample Clock

| | |
|-------------------------------|------------------------------------|
| Source | CLK IN (front panel SMB connector) |
| Frequency range ¹¹ | 50 MHz to 250 MHz |
| Duty cycle tolerance | 45% to 55% |

Phase-Locked Loop (PLL) Reference Clock

| | |
|-------------------------------|---|
| Sources | PXI_CLK10 (backplane connector) CLK IN (front panel SMB connector) |
| Frequency range ¹² | 5 MHz to 20 MHz in 1 MHz increments Default: 10 MHz |

11. Divide by n decimation available where $1 \leq n \leq 65,535$. For more information about the Sample clock and decimation, refer to the [NI High-Speed Digitizers Help](#).

12. The PLL Reference clock frequency must be accurate to ±50 ppm.

| | |
|---------------------------------------|---|
| Duty cycle tolerance | 45% to 55% |
| Exported Reference clock destinations | PFI <0..1> (front panel 9-pin mini-circular DIN connector) PXI_Trig <0..7> |

External Sample Clock and External Reference Clock In

| | |
|----------------------------|---|
| Source | CLK IN (front panel SMB connector) |
| Input voltage range | |
| Sine wave | 0.65 V _{pk-pk} to 2.8 V _{pk-pk} (0 dBm to 13 dBm) |
| Square wave | 0.2 V _{pk-pk} to 2.8 V _{pk-pk} |
| Maximum input overload | 7 V RMS with Peaks ≤ 10 V |
| Impedance | 50 Ω |
| Coupling | AC |

Trigger

Reference (Stop) Trigger

| | |
|-----------------------------|------|
| Trigger types ¹³ | Edge |
|-----------------------------|------|

13. Refer to the following sources and the *NI High-Speed Digitizers Help* for more information about

| | | |
|--|-----------------|-----------------------|
| | Window | |
| | Hysteresis | |
| | Video | |
| | Digital | |
| | Immediate | |
| | Software | |
| Trigger sources | CH 0 | |
| | CH 1 | |
| | TRIG | |
| | PXI_Trig <0..6> | |
| | PFI <0..1> | |
| | RTSI <0..6> | |
| | Software | |
| Time resolution | | |
| Onboard clock, time-to-digital conversion circuit (TDC) on | | 40 ps |
| Onboard clock, TDC off | | 4 ns |
| External clock, TDC off | | External clock period |
| Minimum rearm time¹⁴ | | |

which sources are available for each trigger type.

14. Holdoff set to 0. Onboard Sample clock at maximum rate.

| | |
|---------------|---|
| TDC on | 10 μ s |
| TDC off | 2 μ s |
| Holdoff | From rearm time up to $[(2^{35} - 1) \times \textit{Sample Clock Period}]$ |
| Trigger delay | From 0 up to $[(2^{35} - 1) - \textit{Posttrigger Samples}] \times (1 / \textit{Sample Rate})$, in seconds |

Analog Trigger

| | |
|----------------------------|--|
| Trigger types | Edge Window Hysteresis |
| Sources | CH 0 (front panel BNC connector) CH 1 (front panel BNC connector) TRIG (front panel BNC connector) |
| Trigger level resolution | 8 bits (1 in 256) |
| Trigger level range | |
| CH 0, CH 1 | 100% FS |
| TRIG (external trigger) | ± 5 V |

| Edge trigger sensitivity | |
|----------------------------|---|
| CH 0, CH 1 | 5% FS up to 100 MHz, warranted |
| TRIG (external trigger) | 0.5 V _{pk-pk} up to 125 MHz, warranted |
| Level accuracy | |
| CH 0, CH 1 | ±5% FS up to 100 MHz |
| TRIG (external trigger) | ±0.5 V up to 10 MHz |
| Jitter | ≤65 ps RMS |
| Trigger filters | |
| Low frequency (LF) reject | 50 kHz |
| High frequency (HF) reject | 50 kHz |

Digital Trigger

| | |
|--------------|---|
| Trigger type | Digital |
| Sources | PXI_Trig <0..6> (backplane connector) PFI <0..1> (front panel DIN connector) |

Video Trigger

| | |
|-------------------------------|--|
| Trigger type | Video |
| Sources | CH 0 (front panel BNC connector) CH 1 (front panel BNC connector) TRIG (front panel BNC connector) |
| Video trigger types | Specific Line Any Line Specific Field |
| Standards¹⁵ | |
| SDTV | M-NTSC B/G-PAL SECAM M-PAL |
| EDTV | 480i/59.94 fps 480i/60 fps 480p/59.94 Fps 480p/60 Fps 576i/50 fps 576p/50 Fps |

15. fps = fields per second. Fps = frames per second.

| | |
|--------------------|-----------------|
| HDTV ¹⁶ | 720p/50 Fps |
| | 720p/59.94 Fps |
| | 720p/60 Fps |
| | 1080i/50 fps |
| | 1080i/59.94 fps |
| | 1080i/60 fps |
| | 1080p/24 Fps |

External Trigger

| | |
|----------------------------|-------------------------------------|
| Connector | TRIG (front panel BNC connector) |
| Impedance | 1 M Ω in parallel with 22 pF |
| Coupling | AC, DC |
| AC-coupling cutoff (-3 dB) | 12 Hz |
| Input voltage range | ± 5 V |
| Maximum input overload | Peaks ≤ 42 V |

16. This trigger type does not support negative trigger polarity.

Programmable Function Interface (PFI 0 and PFI 1)

| | |
|------------------------------|---|
| Connector | AUX I/O (front panel 9-pin mini-circular DIN connector) |
| Direction | Bidirectional |
| As an Input (Trigger) | |
| Destinations | <ul style="list-style-type: none"> Start trigger (acquisition arm) Reference (Stop) trigger Arm reference trigger Advance trigger |
| Input impedance | 150 k Ω , nominal |
| V_{IH} | 2.0 V |
| V_{IL} | 0.8 V |
| Maximum input overload | -0.5 V, 5.5 V |
| Maximum frequency | 25 MHz |
| As an Output (Event) | |
| Sources | <ul style="list-style-type: none"> Start trigger (acquisition arm) Reference (Stop) trigger |

| | |
|-----------------------|--|
| | End of Record Done (end of acquisition) Probe Compensation ¹⁷ |
| Output impedance | 50 Ω |
| Logic type | 3.3 V CMOS |
| Maximum drive current | ± 24 mA |
| Maximum frequency | 25 MHz |

Waveform

| | |
|--|--|
| Onboard memory sizes ¹⁸ | 8 MB per channel (standard) 64 MB per channel (option) 256 MB per channel (option) |
| Minimum record length | 1 sample |
| Number of pretrigger samples ^{19[19]} | Zero up to full record length |

17. 1 kHz, 50% duty cycle square wave, PFI 1 only.

18. Onboard memory is shared between enabled channels.

19. Single-record and multirecord acquisitions.

| | |
|---|--|
| Number of posttrigger samples ^[19] | Zero up to full record length |
| Maximum number of records in onboard memory²⁰ | |
| 8 MB | 32,768 |
| 64 MB | 100,000 |
| 256 MB | 100,000 |
| Allocated onboard memory per record | (<i>Record Length</i> × 1 byte/sample) + 240 bytes , rounded up to next multiple of 128 bytes (minimum 256 bytes) |

Calibration

External Calibration

External calibration calibrates the onboard references used in self-calibration and the external trigger levels. All calibration constants are stored in nonvolatile memory.

Self-Calibration

Self-calibration is done on software command. The calibration corrects for gain, offset, triggering, and timing errors for all input ranges.

Related information:

- [For information about when to self-calibrate the device, refer to the NI High-Speed Digitizers Help.](#)

20. You can exceed these numbers if you fetch records while acquiring data. For more information, refer to the [NI High-Speed Digitizers Help](#).

Calibration Specifications

| | |
|-----------------------------------|------------|
| Interval for external calibration | 2 years |
| Warm-up time ²¹ | 15 minutes |

Software

Driver Software

Driver support for this device was first available in NI-SCOPE14.1.

NI-SCOPE is an IVI-compliant driver that allows you to configure, control, and calibrate the PXIe-5114. NI-SCOPE provides application programming interfaces for many development environments.

Application Software

NI-SCOPE provides programming interfaces, documentation, and examples for the following application development environments:

- LabVIEW
- LabWindows™/CVI™
- Measurement Studio
- Microsoft Visual C/C++
- .NET (C# and VB.NET)

Interactive Soft Front Panel and Configuration

When you install NI-SCOPE on a 64-bit system, you can monitor, control, and record measurements from the PXIe-5114 using InstrumentStudio.

InstrumentStudio is a software-based front panel application that allows you to perform interactive measurements on several different device types in a single

21. Warm-up time begins after the NI-SCOPE driver is loaded.

program.



Note InstrumentStudio is supported only on 64-bit systems. If you are using a 32-bit system, use the NI-SCOPE-specific soft front panel instead of InstrumentStudio.

Interactive control of the PXIe-5114 was first available via InstrumentStudio in NI-SCOPE18.1 and via the NI-SCOPE SFP in NI-SCOPE14.1. InstrumentStudio and the NI-SCOPE SFP are included on the NI-SCOPE media.

NI Measurement & Automation Explorer (MAX) also provides interactive configuration and test tools for the PXIe-5114. MAX is included on the driver media.

TClk Specifications

You can use the NI TClk synchronization method and the NI-TClk driver to align the Sample clocks on any number of supported devices, in one or more chassis. For more information about TClk synchronization, refer to the ***NI-TClk Synchronization Help***, which is located within the ***NI High-Speed Digitizers Help***. For other configurations, including multichassis systems, contact NI Technical Support at ni.com/support.

Intermodule SMC Synchronization Using NI-TClk for Identical Modules

Specifications are valid for modules installed in one NI PXI-1042 chassis. These specifications do not apply to PCI modules. Specifications are valid under the following conditions:

- All parameters are set to identical values for each SMC-based module.
- Sample clock set to 250 MS/s.
- All filters are disabled.



Note Although you can use NI-TClk to synchronize non-identical modules, these specifications apply only to synchronizing identical modules.

| | |
|--|--------|
| Skew ²² | 500 ps |
| Average skew after manual adjustment ²³ | <20 ps |
| Sample clock adjustment resolution | <20 ps |

Power

| | |
|--------------|---------|
| Current draw | |
| +3.3 VDC | 1.1 A |
| +12 VDC | 1.5 A |
| Total power | 21.63 W |

Physical

Dimensions and Weight

| | |
|------------|--|
| Dimensions | 21.4 cm × 2.0 cm × 13.0 cm (8.4 in × 0.8 in × 5.1 in) |
| Weight | 501 g (17.7 oz) |

22. Caused by clock and analog path delay differences. No manual adjustment performed.

23. For more information about manual adjustment, refer to the ***Synchronization Repeatability Optimization*** topic in the ***NI-TClk Synchronization Help***.

Figure 3. PXIe-5114

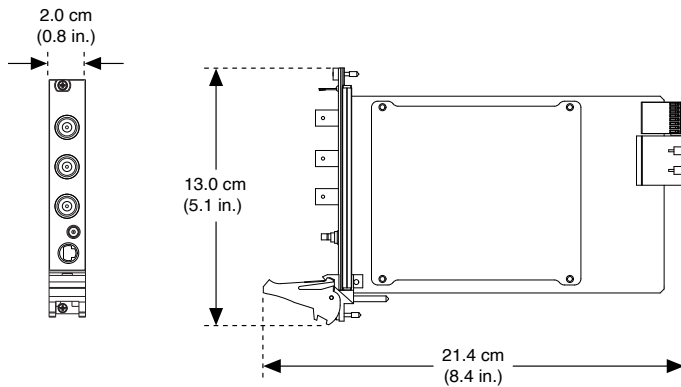

Front Panel

Table 4. PXIe-5114 Front Panel Connectors

| Label | Connector Type | Description |
|---------|-------------------------|--|
| CH 0 | BNC female | Analog input connection; digitizes data and triggers acquisitions. |
| CH 1 | | Analog input connection; digitizes data and triggers acquisitions. |
| TRIG | | External analog trigger; signals on the TRIG connector cannot be digitized. |
| CLK IN | SMB jack | Imports an external Reference clock or Sample clock to the oscilloscope. |
| AUX I/O | 9-pin mini-circular DIN | PFI 0 and PFI 1 lines for digital trigger input/output and probe compensation. |

PXIe-5114 Front Panel LED Indicators

Table 5. PXIe-5114 Front Panel Indicators²⁴

| Label | Description |
|--------|--|
| ACCESS | The ACCESS LED indicates the status of the PCI |

24. For more information, refer to the [NI High-Speed Digitizers Help](#).

| Label | Description |
|--------|--|
| | bus and the interface from the device to the controller. |
| ACTIVE | The ACTIVE LED indicates the status of the onboard acquisition hardware of the device. |

Environment

| | |
|------------------|---|
| Maximum altitude | 2,000 m (800 mbar) (at 25 °C ambient temperature) |
| Pollution Degree | 2 |

Indoor use only.

Operating Environment

| | |
|---------------------------|---------------------------|
| Ambient temperature range | 0 °C to 55 °C |
| Relative humidity range | 10% to 90%, noncondensing |

Storage Environment

| | |
|---------------------------|--------------------------|
| Ambient temperature range | -40 °C to 71 °C |
| Relative humidity range | 5% to 95%, noncondensing |

Shock and Vibration

| | |
|-------------------------|-----------------------------------|
| Operating shock | 30 g peak, half-sine, 11 ms pulse |
| Random vibration | |
| Operating | 5 Hz to 500 Hz, 0.3 g RMS |
| Nonoperating | 5 Hz to 500 Hz, 2.4 g RMS |

Compliance and Certifications

Safety Compliance Standards

This product is designed to meet the requirements of the following electrical equipment safety standards for measurement, control, and laboratory use:

- IEC 61010-1, EN 61010-1
- UL 61010-1, CSA C22.2 No. 61010-1



Note For safety certifications, refer to the product label or the [Product Certifications and Declarations](#) section.

Electromagnetic Compatibility

This product meets the requirements of the following EMC standards for electrical equipment for measurement, control, and laboratory use:

- EN 61326-1 (IEC 61326-1): Class A emissions; Basic immunity
- EN 55011 (CISPR 11): Group 1, Class A emissions
- EN 55022 (CISPR 22): Class A emissions
- EN 55024 (CISPR 24): Immunity
- AS/NZS CISPR 11: Group 1, Class A emissions
- AS/NZS CISPR 22: Class A emissions

- FCC 47 CFR Part 15B: Class A emissions
- ICES-001: Class A emissions



Note In the United States (per FCC 47 CFR), Class A equipment is intended for use in commercial, light-industrial, and heavy-industrial locations. In Europe, Canada, Australia, and New Zealand (per CISPR 11), Class A equipment is intended for use only in heavy-industrial locations.



Note Group 1 equipment (per CISPR 11) is any industrial, scientific, or medical equipment that does not intentionally generate radio frequency energy for the treatment of material or inspection/analysis purposes.



Note For EMC declarations, certifications, and additional information, refer to the [Product Certifications and Declarations](#) section.

CE Compliance

This product meets the essential requirements of applicable European Directives, as follows:

- 2014/35/EU; Low-Voltage Directive (safety)
- 2014/30/EU; Electromagnetic Compatibility Directive (EMC)
- 2011/65/EU; Restriction of Hazardous Substances (RoHS)

Product Certifications and Declarations

Refer to the product Declaration of Conformity (DoC) for additional regulatory compliance information. To obtain product certifications and the DoC for NI products, visit ni.com/product-certifications, search by model number, and click the appropriate link.

Environmental Management

NI is committed to designing and manufacturing products in an environmentally responsible manner. NI recognizes that eliminating certain hazardous substances from our products is beneficial to the environment and to NI customers.

For additional environmental information, refer to the ***Engineering a Healthy Planet*** web page at ni.com/environment. This page contains the environmental regulations and directives with which NI complies, as well as other environmental information not included in this document.

EU and UK Customers

-  **Waste Electrical and Electronic Equipment (WEEE)**—At the end of the product life cycle, all NI products must be disposed of according to local laws and regulations. For more information about how to recycle NI products in your region, visit ni.com/environment/weee.

电子信息产品污染控制管理办法（中国RoHS）

-  **中国RoHS**—NI符合中国电子信息产品中限制使用某些有害物质指令 (RoHS)。关于NI中国RoHS合规性信息，请登录 ni.com/environment/rohs_china。(For information about China RoHS compliance, go to ni.com/environment/rohs_china.)