

---

# PXle-4143

# Specifications

---

2025-09-23



# Contents

PXIe-4143 Specifications ..... 3

# PXIe-4143 Specifications

## Definitions

**Warranted** specifications describe the performance of a model under stated operating conditions and are covered by the model warranty.

**Characteristics** describe values that are relevant to the use of the model under stated operating conditions but are not covered by the model warranty.

- **Typical** specifications describe the performance met by a majority of models.
- **Nominal** specifications describe an attribute that is based on design, conformance testing, or supplemental testing.

Specifications are **Warranted** unless otherwise noted.

## Conditions

Specifications are valid under the following conditions unless otherwise noted.

- Ambient temperature<sup>1</sup> of  $23\text{ °C} \pm 5\text{ °C}$
- Calibration interval of 1 year
- 30 minutes warm-up time
- Self-calibration performed within the last 24 hours
- niDCPower Aperture Time property or NIDCPOWER\_ATTR\_APERTURE\_TIME attribute set to 2 power-line cycles (PLC)
- Fans set to the highest setting if the PXI Express chassis has multiple fan speed settings

## PXIe-4143 Pinout

The following figure shows the terminals on the PXIe-4143 connector.

1. The ambient temperature of a PXI system is defined as the temperature at the chassis fan inlet (air intake).

Figure 1. PXIe-4143 Connector Pinout

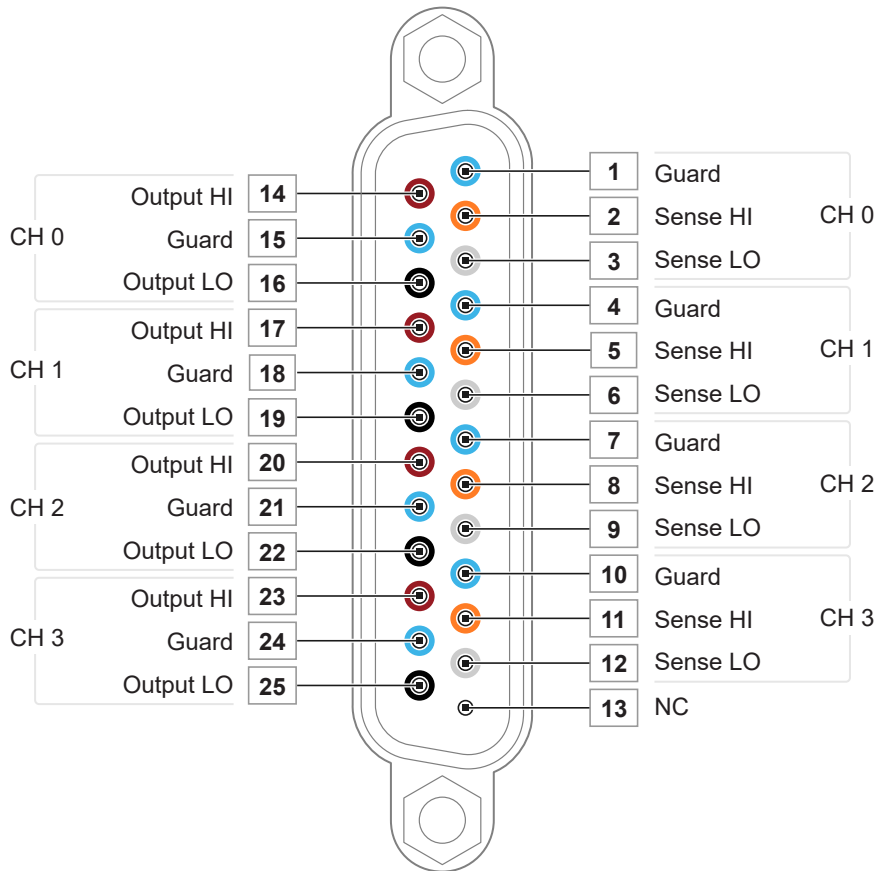

Table 1. Signal Descriptions

Signal Name	Description
CH <0..3> Output HI	HI force terminal connected to channel power stage (generates and/or dissipates power). Positive polarity is defined as voltage measured on HI > LO.
CH <0..3> Guard	Buffered output that follows the voltage of the HI force terminal. Used to drive shield conductors surrounding HI force and Sense HI conductors to minimize effects of leakage and capacitance on low level currents.
CH <0..3> Output LO	LO force terminal connected to channel power stage (generates and/or dissipates power). Positive polarity is defined as voltage measured on HI > LO.
CH <0..3> Sense HI	Voltage remote sense input terminals. Used to compensate for $I \cdot R$ voltage drops in cable leads, connectors, and switches.
CH <0..3> Sense LO	
NC	No Connect.



**Note** PXIe-4143 channels are bank-isolated from earth ground, but also share a common LO.

## Device Capabilities

The following table and figure illustrate the voltage and the current source and sink ranges of the PXIe-4143.

Table 2. PXIe-4143 Current Source and Sink Ranges

Channels	DC Voltage Ranges	DC Current Source and Sink Ranges
0 through 3 <sup>*</sup>	$\pm 24$ V	<ul style="list-style-type: none"> <li>• 10 <math>\mu</math>A</li> <li>• 100 <math>\mu</math>A</li> <li>• 1 mA</li> <li>• 10 mA</li> <li>• 150 mA</li> </ul>
<p><sup>*</sup> Channels are isolated from earth ground but share a common LO.</p>		

Figure 2. PXle-4143 Quadrant Diagram, All Channels

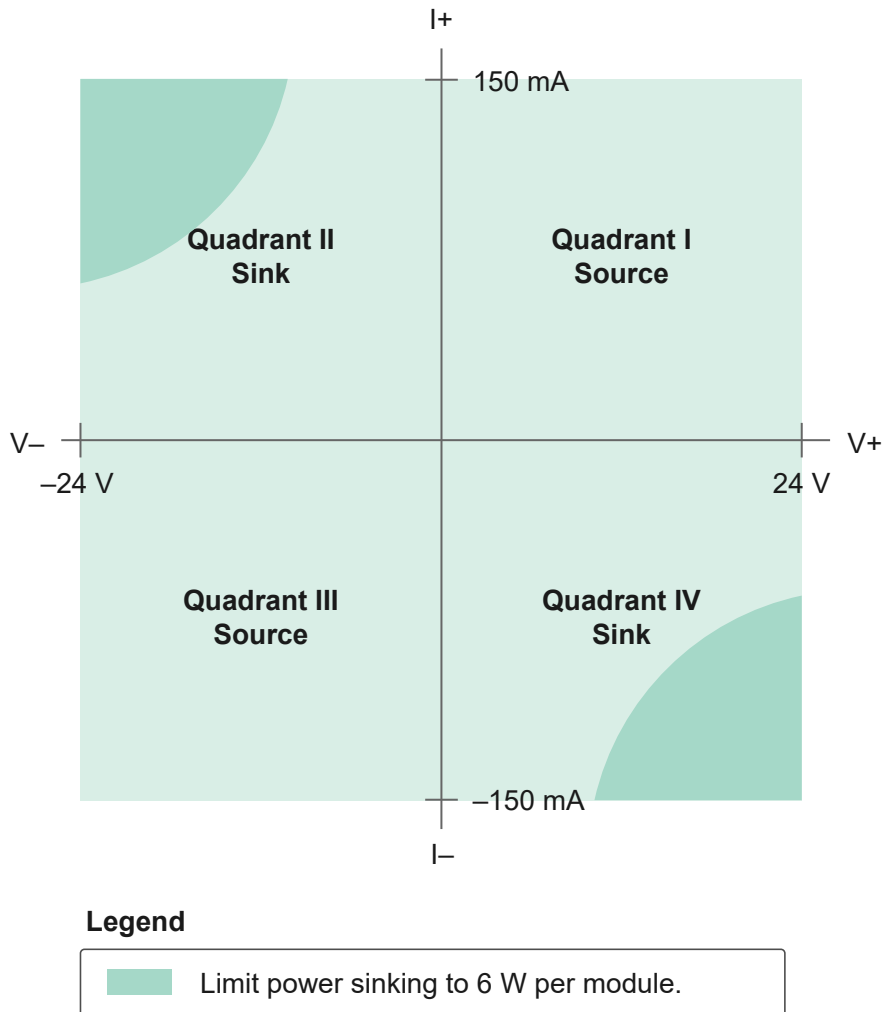

## SMU Specifications

### Voltage Programming and Measurement Accuracy/Resolution

Table 3. Voltage Programming and Measurement Accuracy/Resolution

Range	Resolution and noise (0.1 Hz to 10 Hz)	Accuracy ( $23\text{ }^{\circ}\text{C} \pm 5\text{ }^{\circ}\text{C}$ ) $\pm$ (% of voltage + offset) <sup>2</sup>		Tempco $\pm$ (% of voltage + offset)/ $^{\circ}\text{C}$ , $0\text{ }^{\circ}\text{C}$ to $55\text{ }^{\circ}\text{C}$ <sup>3</sup>
		$T_{\text{cal}} \pm 5\text{ }^{\circ}\text{C}$	$T_{\text{cal}} \pm 1\text{ }^{\circ}\text{C}$	
24 V	20 $\mu\text{V}$	0.015% + 1.2 mV	0.013% + 300 $\mu\text{V}$	0.0005% + 1 $\mu\text{V}$

- Accuracy is specified for no load output configurations. Refer to Load Regulation and Remote Sense in the **Additional Specifications** section for additional accuracy derating and conditions.
- Temperature Coefficient applies beyond  $23\text{ }^{\circ}\text{C} \pm 5\text{ }^{\circ}\text{C}$  within a given tolerance of  $T_{\text{cal}}$ .

**Related tasks:**

- [Calculating SMU Resolution](#)

**Related reference:**

- [Additional Specifications](#)

## Current

Table 4. Current Programming and Measurement Accuracy/Resolution

Range	Resolution and noise (0.1 Hz to 10 Hz)	Accuracy (23 °C ± 5 °C) ± (% of current + offset)		Tempco ± (% of current + offset)/°C, 0 °C to 55 °C <sup>4</sup>
		T <sub>cal</sub> ± 5 °C	T <sub>cal</sub> ± 1 °C	
10 µA	10 pA	0.03% + 1.6 nA	0.03% + 400 pA	0.002% + 10 pA
100 µA	100 pA	0.03% + 16 nA	0.03% + 4.0 nA	0.002% + 100 pA
1 mA	1 nA	0.03% + 160 nA	0.03% + 40 nA	0.002% + 1.0 nA
10 mA	10 nA	0.03% + 1.6 µA	0.03% + 400 nA	0.002% + 10 nA
150 mA	150 nA	0.03% + 24 µA	0.03% + 6.0 µA	0.002% + 150 nA

**Related tasks:**

- [Calculating SMU Resolution](#)

**Related reference:**

- [Additional Specifications](#)

## Output Resistance Programming Accuracy/Resolution, Typical

Table 5. Output Resistance Programming Accuracy/Resolution, Typical

Current limit range	Programmable resistance range	Resolution	Accuracy ± (% of resistance setting), T <sub>cal</sub> ± 5 °C
10 µA	± 100 kΩ	2 Ω	0.04% + 1.0 Ω

4. Temperature Coefficient applies beyond 23 °C ± 5 °C within a given tolerance of T<sub>cal</sub>.

Current limit range	Programmable resistance range	Resolution	Accuracy $\pm$ (% of resistance setting), $T_{cal} \pm 5^\circ\text{C}$
100 $\mu\text{A}$	$\pm 10\text{ k}\Omega$	200 $\text{m}\Omega$	0.04% + 110 $\text{m}\Omega$
1 mA	$\pm 1\text{ k}\Omega$	20 $\text{m}\Omega$	0.04% + 20 $\text{m}\Omega$
10 mA	$\pm 100\ \Omega$	2 $\text{m}\Omega$	0.04% + 11 $\text{m}\Omega$
150 mA	$\pm 6.66\ \Omega$	120 $\mu\Omega$	0.04% + 10 $\text{m}\Omega$

## Calculating SMU Resolution

Refer to the following figure as you complete the following steps to derive a resolution in absolute units:

Figure 3. Noise and Resolution versus Measurement Aperture, Typical

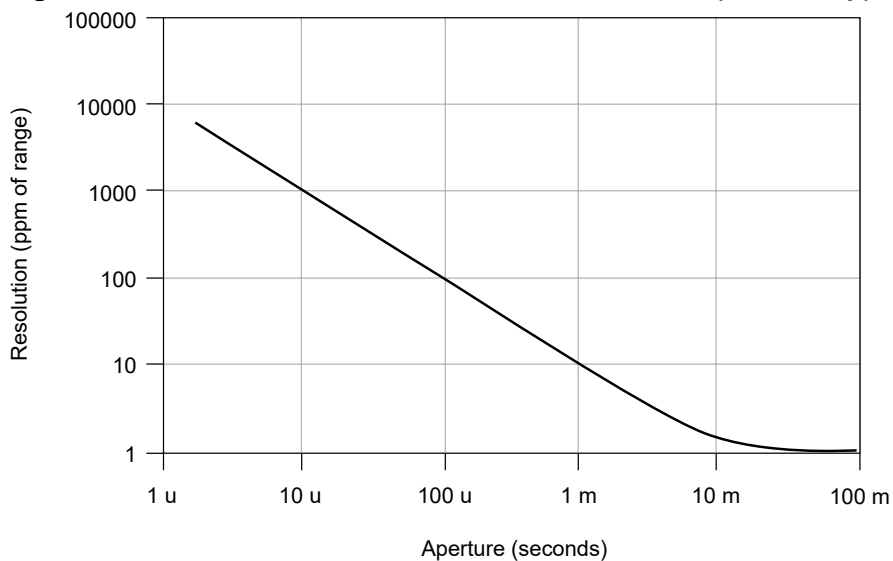

1. Select a voltage or current range.
2. For a given aperture time, find the corresponding resolution.
3. To convert resolution from ppm of range to absolute units, multiply resolution in ppm of range by the selected range.

## Example of Calculating SMU Resolution

The PXle-4143 has a resolution of 100 ppm when set to a 100  $\mu\text{s}$  aperture time. In the 24 V range, resolution can be calculated by multiplying 24 V by 100 ppm, as shown in

the following equation:

$$24 \text{ V} * 100 \text{ ppm} = 24 \text{ V} * 100 * 1 \times 10^{-6} = 2.4 \text{ mV}$$

Likewise, in the 150 mA range, resolution can be calculated by multiplying 150 mA by 100 ppm, as shown in the following equation:

$$150 \text{ mA} * 100 \text{ ppm} = 150 \text{ mA} * 100 * 1 \times 10^{-6} = 15 \text{ } \mu\text{A}$$

## Additional Specifications

Settling time <sup>5</sup>	<100 $\mu\text{s}$ to settle to 0.1% of voltage step, device configured for fast transient response, typical
Transient response	<100 $\mu\text{s}$ to recover within $\pm 20 \text{ mV}$ after a load current change from 10% to 90% of range, device configured for fast transient response, typical
Wideband source noise <sup>6</sup>	2 mV RMS, typical <20 mV <sub>pk-pk</sub> , typical
Cable guard output impedance	10 k $\Omega$ , typical

Remote sense	
Voltage	Add 0.1% of LO lead drop to voltage accuracy specification
Current	Add 0.03% of range per volt of total HI and LO lead drop to current accuracy

5. Current limit set to  $\geq 1 \text{ mA}$  and  $\geq 10\%$  of the selected current limit range.

6. 20 Hz to 20 MHz bandwidth. PXIe-4143 configured for normal transient response.

	specification
Maximum lead drop	Up to 1 V drop per lead

Load regulation	
Voltage	10 $\mu$ V at connector pins per mA of output load when using local sense, typical
Current	20 pA + (10 ppm of range per volt of output change) when using local sense, typical

Isolation voltage, channel-to-earth ground <sup>7</sup>	60 VDC, CAT I, verified by dielectric withstand test, 5 s, continuous
Absolute maximum voltage between any terminal and LO	30 VDC, continuous

The following figures illustrate the effect of the transient response setting on the step response of the PXIe-4143 for different loads.

7. Channels are isolated from earth ground but share a common LO.

Figure 4. 1 mA Range No Load Step Response, Typical

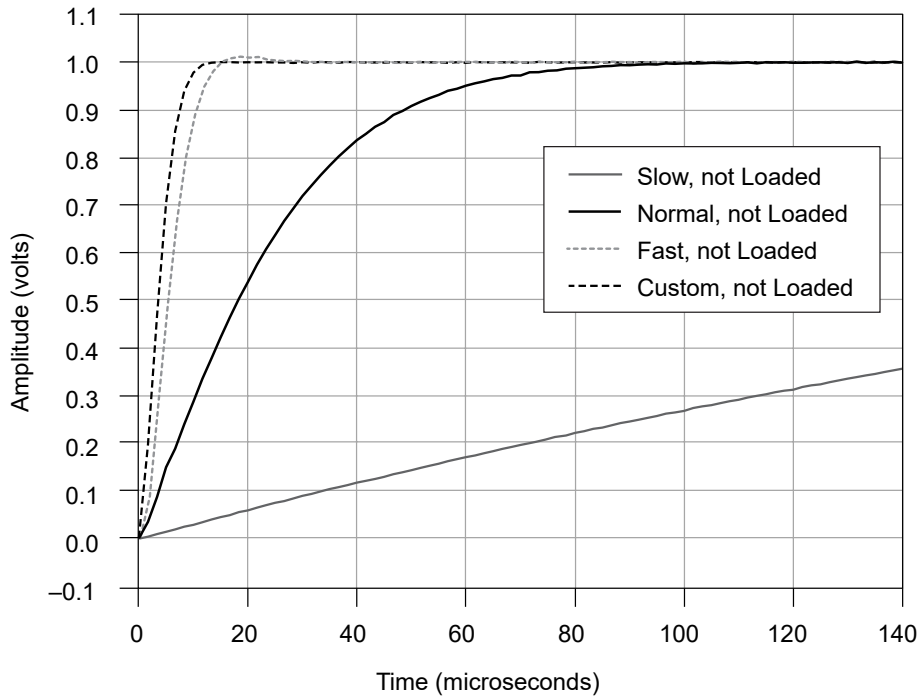
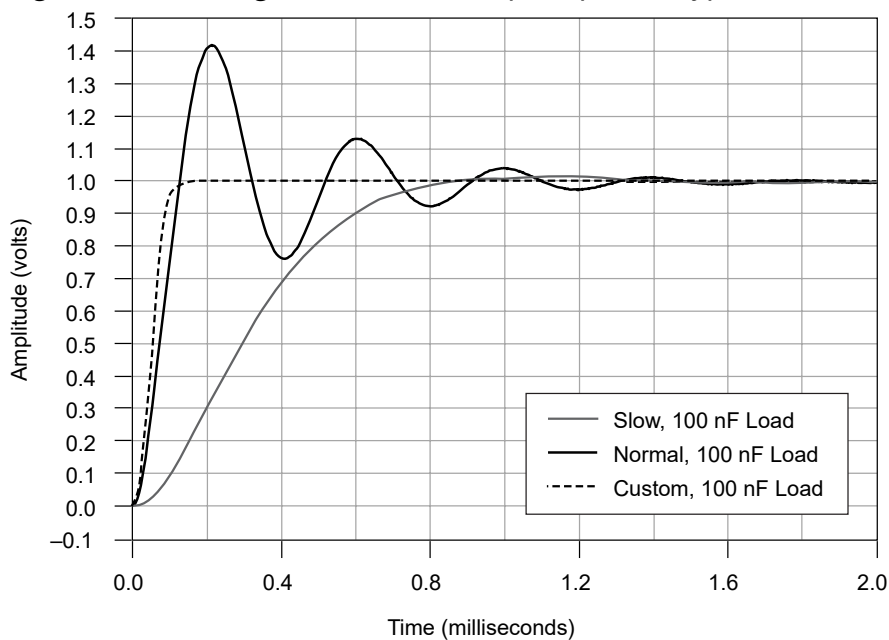

Figure 5. 1 mA Range, 100 nF Load Step Response, Typical

**Related reference:**

- [Voltage Programming and Measurement Accuracy/Resolution](#)
- [Current](#)

# Supplemental Specifications

## Measurement and Update Timing

Available sample rates <sup>8</sup>	(600 kS/s)/N
-------------------------------------	--------------

where

- $N = 6, 7, 8, \dots, 2^{20}$
- S is samples

Sample rate accuracy	±50 ppm
Maximum measure rate to host <sup>9</sup>	600,000 S/s per channel, continuous
<b>Maximum source update rate<sup>10</sup></b>	
Sequence length <300 steps per iteration	100,000 updates/s per channel
Sequence length ≥300 steps per iteration	100,000 updates/s per board
<b>Input trigger to</b>	
Source event delay	5 μs

8. When source-measuring, both the NI-DCPower Source Delay and Aperture Time properties affect the sampling rate. When taking a measure record, only the Aperture Time property affects the sampling rate.

9. Load dependent settling time is not included. Normal DC noise rejection is used.

10. As the source delay is adjusted or if advanced sequencing is used, maximum source update rates may vary.

Source event jitter	1.7 $\mu$ s
Measure event jitter	1.7 $\mu$ s

## Triggers

<b>Input triggers</b>	
Types	Start Source Sequence Advance Measure
<b>Sources (PXI trigger lines 0 to 7)</b>	
Polarity	Configurable
Minimum pulse width	100 ns, nominal
<b>Destinations<sup>11</sup> (PXI trigger lines 0 to 7)</b>	
Polarity	Active high (not configurable)
Minimum pulse width	>200 ns, nominal
<b>Output triggers (events)</b>	

11. Input triggers can come from any source (PXI trigger or software trigger) and be exported to any PXI trigger line. This allows for easier multi-board synchronization regardless of the trigger source.

Types	Source Complete Sequence Iteration Complete Sequence Engine Done Measure Complete
<b>Destinations (PXI trigger lines 0 to 7)</b>	
Polarity	Configurable
Pulse width	Configurable between 250 ns and 1.6 $\mu$ s, nominal



**Note** Pulse widths and logic levels are compliant with *PXI Express Hardware Specification Revision 1.0 ECN 1*.

## Calibration Interval

Recommended calibration interval	1 year
----------------------------------	--------

## Physical

Dimensions	3U, one-slot, PXI Express/CompactPCI Express module 2.0 cm $\times$ 13.0 cm $\times$ 21.6 cm (0.8 in. $\times$ 5.1 in. $\times$ 8.5 in.)
Weight	412 g (14.53 oz)

Front panel connectors	25-position D-SUB, male
------------------------	-------------------------

## Power Requirements

PXI Express power requirement	2 A from the 12 V rail and 1.9 A from the 3.3 V rail
-------------------------------	--

## Environmental Characteristics

Table 6. Temperature

Operating	0 °C to 55 °C
Storage	-40 °C to 70 °C

Table 7. Humidity

Operating	10% to 70%, noncondensing. Derate 1.3% per °C above 40 °C.
Storage	5% to 95%, noncondensing.

Table 8. Pollution Degree

Pollution degree	2
------------------	---

Table 9. Maximum Altitude

Maximum altitude	2,000 m (800 mbar) (at 25 °C ambient temperature)
------------------	---

Table 10. Shock and Vibration

Operating vibration	5 Hz to 500 Hz, 0.3 g RMS
Non-operating vibration	5 Hz to 500 Hz, 2.4 g RMS
Operating shock	30 g, half-sine, 11 ms pulse