PXle-4141

Specifications

2025-09-23



Contents

PXIe-4141 Specifications..... 3

PXIe-4141 Specifications

Definitions

Warranted specifications describe the performance of a model under stated operating conditions and are covered by the model warranty.

Characteristics describe values that are relevant to the use of the model under stated operating conditions but are not covered by the model warranty.

- **Typical** specifications describe the performance met by a majority of models.
- **Nominal** specifications describe an attribute that is based on design, conformance testing, or supplemental testing.

Specifications are **Warranted** unless otherwise noted.

Conditions

Specifications are valid under the following conditions unless otherwise noted.

- Ambient temperature¹ of $23\text{ °C} \pm 5\text{ °C}$
- Calibration interval of 1 year
- 30 minutes warm-up time
- Self-calibration performed within the last 24 hours
- niDCPower Aperture Time property or NIDCPOWER_ATTR_APERTURE_TIME attribute set to 2 power-line cycles (PLC)
- Fans set to the highest setting if the PXI Express chassis has multiple fan speed settings

PXIe-4141 Pinout

The following figure shows the terminals on the PXIe-4141 connector.

1. The ambient temperature of a PXI system is defined as the temperature at the chassis fan inlet (air intake).

Figure 4. PXle-4141 Connector Pinout

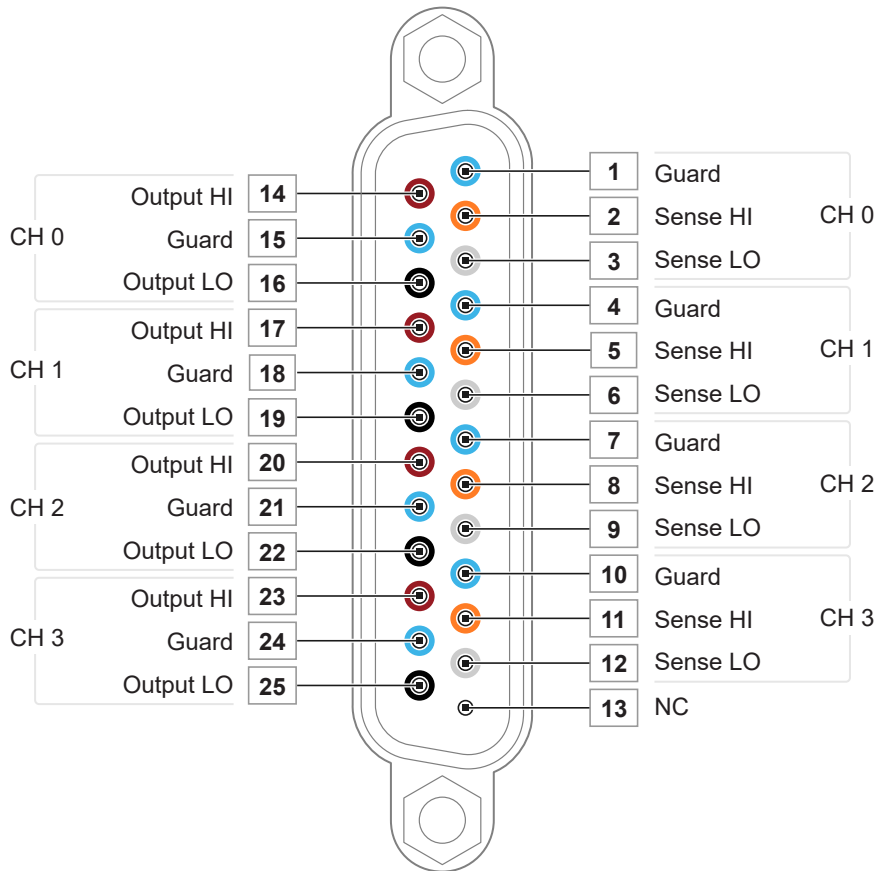

Table 4. Signal Descriptions

Signal Name	Description
CH <0..3> Output HI	HI force terminal connected to channel power stage (generates and/or dissipates power). Positive polarity is defined as voltage measured on HI > LO.
CH <0..3> Guard	Buffered output that follows the voltage of the HI force terminal. Used to drive shield conductors surrounding HI force and Sense HI conductors to minimize effects of leakage and capacitance on low level currents.
CH <0..3> Output LO	LO force terminal connected to channel power stage (generates and/or dissipates power). Positive polarity is defined as voltage measured on HI > LO.
CH <0..3> Sense HI	Voltage remote sense input terminals. Used to compensate for $I \cdot R$ voltage drops in cable leads, connectors, and switches.
CH <0..3> Sense LO	
NC	No Connect.



Note PXIe-4141 channels are bank-isolated from earth ground, but also share a common LO.

Device Capabilities

The following table and figure illustrate the voltage and the current source and sink ranges of the PXIe-4141.

Table 5. Current Source and Sink Ranges

Channels	DC Voltage Ranges	DC Current Source and Sink Ranges
0 through 3 [*]	± 10 V	<ul style="list-style-type: none"> • 10 μA • 100 μA • 1 mA • 10 mA • 100 mA
<p>[*] Channels are isolated from earth ground but share a common LO.</p>		

Figure 5. Quadrant Diagram, All Channels

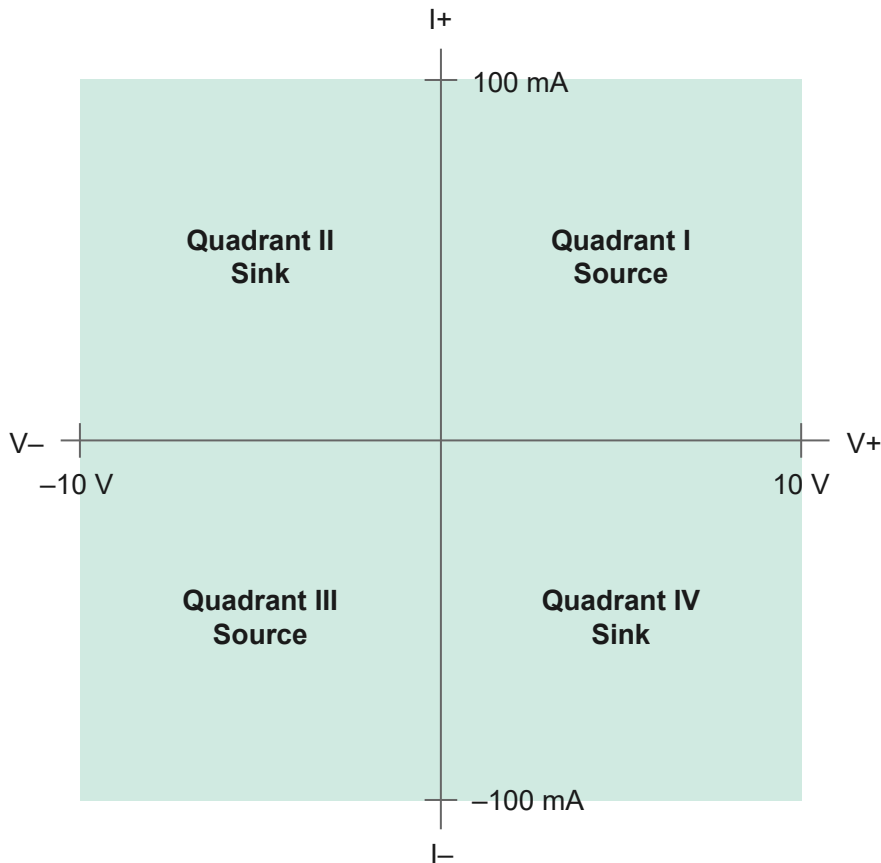

SMU Specifications

Voltage Programming and Measurement Accuracy/Resolution

Table 6. Voltage Programming and Measurement Accuracy/Resolution

Range	Resolution and noise (0.1 Hz to 10 Hz)	Accuracy (23 °C ± 5 °C) ± (% of voltage + offset) ²		Tempco ± (% of voltage + offset)/°C, 0 °C to 55 °C
		T _{cal} ± 5 °C	T _{cal} ± 1 °C	
10 V	10 µV	0.015% + 600 µV	0.013% + 150 µV	0.0005% + 1 µV

Related tasks:

- [Calculating SMU Resolution](#)

2. Accuracy is specified for no load output configurations. Refer to Load Regulation and Remote Sense in the **Additional Specifications** section for additional accuracy derating and conditions.

Related reference:

- [Additional Specifications](#)

Current

Table 7. Current Programming and Measurement Accuracy/Resolution

Range	Resolution and noise (0.1 Hz to 10 Hz)	Accuracy (23 °C ± 5 °C) ± (% of current + offset)		Tempco ± (% of current + offset)/°C, 0 °C to 55 °C
		T _{cal} ± 5 °C	T _{cal} ± 1 °C	
10 µA	10 pA	0.03% + 1.5 nA	0.03% + 300 pA	0.002% + 10 pA
100 µA	100 pA	0.03% + 15 nA	0.03% + 3.0 nA	0.002% + 100 pA
1 mA	1 nA	0.03% + 150 nA	0.03% + 30 nA	0.002% + 1.0 nA
10 mA	10 nA	0.03% + 1.5 µA	0.03% + 300 nA	0.002% + 10 nA
100 mA	100 nA	0.03% + 15 µA	0.03% + 3.0 µA	0.002% + 100 nA

Related tasks:

- [Calculating SMU Resolution](#)

Related reference:

- [Additional Specifications](#)

Output Resistance Programming Accuracy/Resolution, Typical

Table 8. Output Resistance Programming Accuracy/Resolution, Typical

Current limit range	Programmable resistance range	Resolution	Accuracy ± (% of resistance setting), T _{cal} ± 5 °C
10 µA	± 100 kΩ	1 Ω	0.04% + 510 mΩ
100 µA	± 10 kΩ	100 mΩ	0.04% + 60 mΩ
1 mA	± 1 kΩ	10 mΩ	0.04% + 15 mΩ
10 mA	± 100 Ω	1 mΩ	0.04% + 10 mΩ

Current limit range	Programmable resistance range	Resolution	Accuracy \pm (% of resistance setting), $T_{cal} \pm 5^\circ\text{C}$
100 mA	$\pm 10\ \Omega$	100 $\mu\Omega$	0.04% + 10 m Ω

Calculating SMU Resolution

Refer to the following figure as you complete the following steps to derive a resolution in absolute units:

Figure 6. Noise and Resolution versus Measurement Aperture, Typical

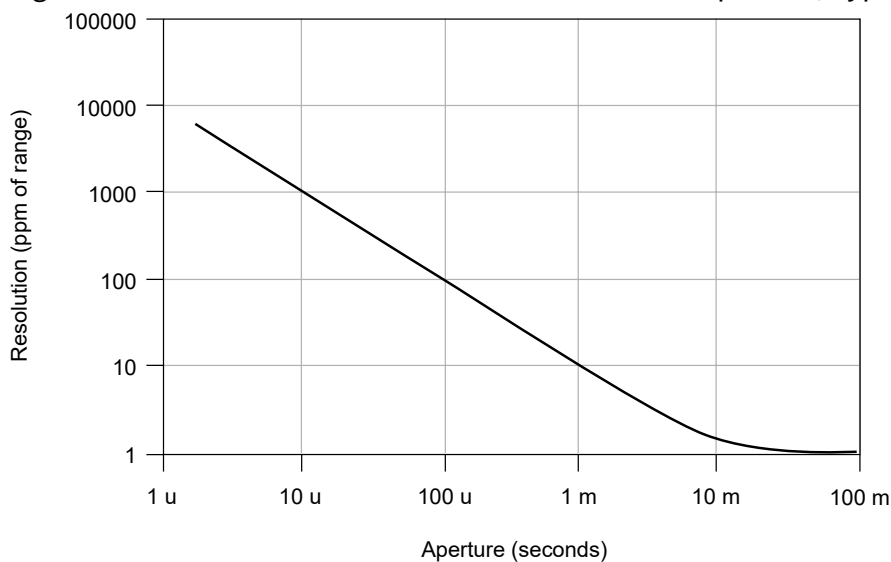

1. Select a voltage or current range.
2. For a given aperture time, find the corresponding resolution.
3. To convert resolution from ppm of range to absolute units, multiply resolution in ppm of range by the selected range.

Related reference:

- [Voltage Programming and Measurement Accuracy/Resolution](#)
- [Current](#)

Example of Calculating SMU Resolution

The PXle-4141 has a resolution of 100 ppm when set to a 100 μs aperture time. In the

10 V range, resolution can be calculated by multiplying 10 V by 100 ppm, as shown in the following equation:

$$10 \text{ V} * 100 \text{ ppm} = 10 \text{ V} * 100 * 1 \times 10^{-6} = 1 \text{ mV}$$

Likewise, in the 100 mA range, resolution can be calculated by multiplying 100 mA by 100 ppm, as shown in the following equation:

$$100 \text{ mA} * 100 \text{ ppm} = 100 \text{ mA} * 100 * 1 \times 10^{-6} = 10 \text{ } \mu\text{A}$$

Additional Specifications

Settling time ³	<100 μs to settle to 0.1% of voltage step, device configured for fast transient response, typical
Transient response	<100 μs to recover within $\pm 20 \text{ mV}$ after a load current change from 10% to 90% of range, device configured for fast transient response, typical
Wideband source noise ⁴	1.5 mV RMS, typical <20 mV _{pk-pk} , typical
Cable guard output impedance	10 k Ω , typical

Remote sense	
Voltage	Add 0.1% of LO lead drop to voltage accuracy specification

3. Current limit set to $\geq 1 \text{ mA}$ and $\geq 10\%$ of the selected current limit range.

4. 20 Hz to 20 MHz bandwidth. PXIe-4141 configured for normal transient response.

Current	Add 0.02% of range per volt of total HI and LO lead drop to current accuracy specification
Maximum lead drop	Up to 1 V drop per lead

Load regulation	
Voltage	10 μ V at connector pins per mA of output load when using local sense, typical
Current	20 pA + (10 ppm of range per volt of output change) when using local sense, typical

Isolation voltage, channel-to-earth ground ⁵	60 VDC, CAT I, verified by dielectric withstand test, 5 s, continuous
Absolute maximum voltage between any terminal and LO	20 VDC, continuous

The following figures illustrate the effect of the transient response setting on the step response of the PXIe-4141 for different loads.

5. Channels are isolated from earth ground but share a common LO.

Figure 7. 1 mA Range No Load Step Response, Typical

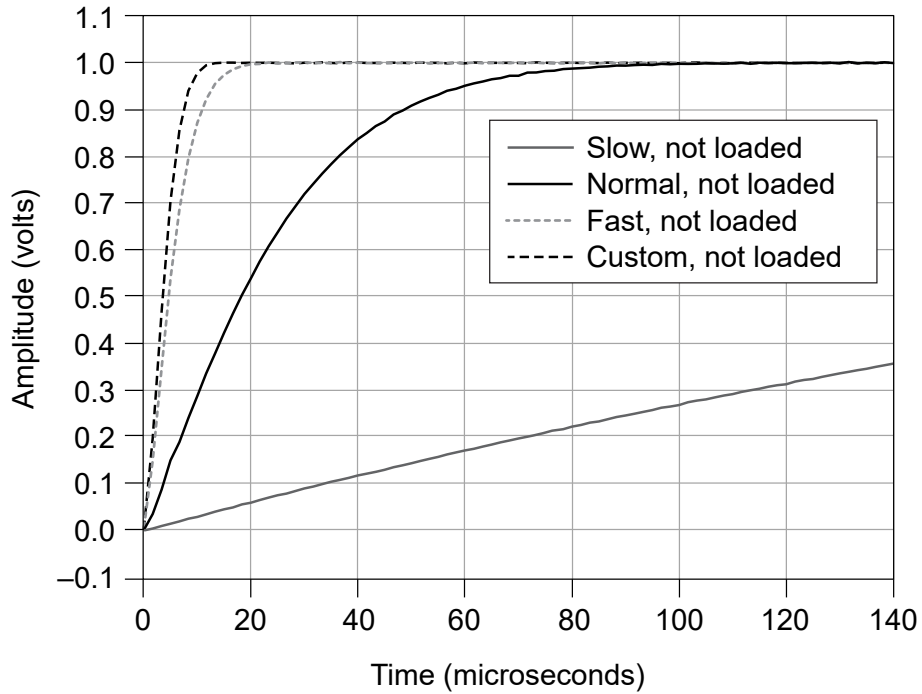
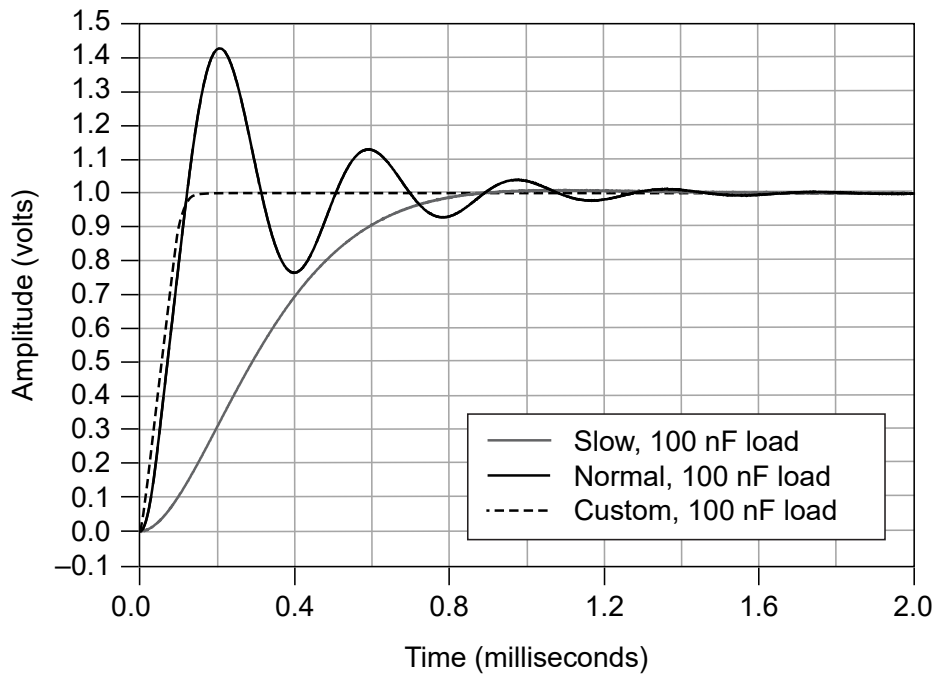

Figure 8. 1 mA Range, 100 nF Load Step Response, Typical

**Related reference:**

- [Voltage Programming and Measurement Accuracy/Resolution](#)
- [Current](#)

Supplemental Specifications

Measurement and Update Timing

Available sample rates ⁶	(600 kS/s)/N
-------------------------------------	--------------

where

- $N = 6, 7, 8, \dots, 2^{20}$
- S is samples

Sample rate accuracy	±50 ppm
Maximum measure rate to host ⁷	600,000 S/s per channel, continuous
Maximum source update rate⁸	
Sequence length <300 steps per iteration	100,000 updates/s per channel
Sequence length ≥300 steps per iteration	100,000 updates/s per board
Input trigger to	
Source event delay	5 μs

6. When source-measuring, both the NI-DCPower Source Delay and Aperture Time properties affect the sampling rate. When taking a measure record, only the Aperture Time property affects the sampling rate.

7. Load dependent settling time is not included. Normal DC noise rejection is used.

8. As the source delay is adjusted or if advanced sequencing is used, maximum source update rates may vary.

Source event jitter	1.7 μ s
Measure event jitter	1.7 μ s

Triggers

Input triggers	
Types	Start Source Sequence Advance Measure
Sources (PXI trigger lines 0 to 7)	
Polarity	Configurable
Minimum pulse width	100 ns, nominal
Destinations⁹ (PXI trigger lines 0 to 7)	
Polarity	Active high (not configurable)
Minimum pulse width	>200 ns, nominal
Output triggers (events)	

9. Input triggers can come from any source (PXI trigger or software trigger) and be exported to any PXI trigger line. This allows for easier multi-board synchronization regardless of the trigger source.

Types	Source Complete Sequence Iteration Complete Sequence Engine Done Measure Complete
Destinations (PXI trigger lines 0 to 7)	
Polarity	Configurable
Pulse width	Configurable between 250 ns and 1.6 μ s, nominal



Note Pulse widths and logic levels are compliant with *PXI Express Hardware Specification Revision 1.0 ECN 1*.

Calibration Interval

Recommended calibration interval	1 year
----------------------------------	--------

Physical

Dimensions	3U, one-slot, PXI Express/CompactPCI Express module 2.0 cm \times 13.0 cm \times 21.6 cm (0.8 in. \times 5.1 in. \times 8.5 in.)
Weight	425 g (14.99 oz)

Front panel connectors	25-position D-SUB, male
------------------------	-------------------------

Power Requirements

PXI Express power requirement	600 mA from the 12 V rail and 350 mA from the 3.3 V rail
-------------------------------	--

Environmental Characteristics

Table 9. Temperature

Operating	0 °C to 55 °C
Storage	-40 °C to 70 °C

Table 10. Humidity

Operating	10% to 70%, noncondensing. Derate 1.3% per °C above 40 °C.
Storage	5% to 95%, noncondensing.

Table 11. Pollution Degree

Pollution degree	2
------------------	---

Table 12. Maximum Altitude

Maximum altitude	2,000 m (800 mbar) (at 25 °C ambient temperature)
------------------	---

Table 13. Shock and Vibration

Operating vibration	5 Hz to 500 Hz, 0.3 g RMS
Non-operating vibration	5 Hz to 500 Hz, 2.4 g RMS
Operating shock	30 g, half-sine, 11 ms pulse