

Agilent N1810/1/2 Coaxial Switches

High Quality Electromechanical Switches for Microwave and RF Manufacturing Test Systems

Product Overview

- High isolation - > 120 dB @ 4 GHz
- High repeatability - < 0.03 dB typical
- Low SWR - < 1.10 @ 4 GHz
- Low-insertion loss - < 0.27 dB @ 4 GHz
- Long life - > 5 million cycles

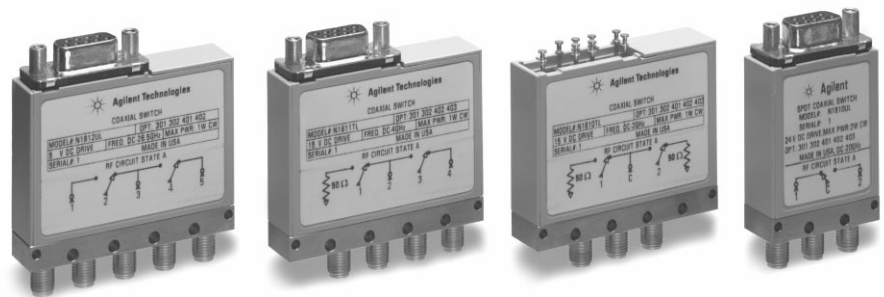

The solution for high-volume wireless communications test

- dc to 2 GHz
- dc to 4 GHz
- dc to 20 GHz
- dc to 26.5 GHz

In today's fast moving technical industries, test engineers need components they can count on. Agilent now offers a new line of latching coaxial switches that combine legendary reliability with the widest range of performance options available today.

Reduce downtime

Agilent Technologies is the world leader in innovating and developing microwave accessories for communications and aerospace applications. Our innovative design and strict adherence to quality process control ensure that each switch is guaranteed to perform within warranted specifications for its entire lifetime. With fewer breakdowns and less need to recalibrate, your test system moves quicker with less downtime, creating more throughput and revenue.

Raise your standards

All Agilent switches offer excellent repeatability and long life – up to five times the lifecycles of the competition. Add to this aggressive specs for isolation, SWR, and insertion loss, and you have a switch that impresses even the most demanding engineer with its precision and durability.

Increase flexibility

For test systems that require extra functionality or increased performance, the N181x family of switches has a solution that fits your need. The options include:

- Reduced SWR
- Increased isolation
- Standard or TTL drive
- 5, 15, 24 volt drive
- Position indicators
- Current interrupts

Increase productivity

When you buy your switches from Agilent, you notice a difference. Your test platforms run smoother, longer and faster, while yielding more viable and valuable measurements.



Agilent Technologies

Description

N1810UL

Unterminated latching

The Agilent N1810UL is a single-pole double-throw switch available in the frequency range from dc to 26.5 GHz. In precision measurements and monitoring applications where insertion loss repeatability is crucial, these switches operate in excess of 5 million cycles with better than .03 dB of insertion loss repeatability at 25°C.

N1810TL

Terminated latching

The Agilent N1810TL is a single-pole double-throw switch available in the frequency range from dc to 26.5 GHz. The unused port is terminated 50 ohms, making it ideal for applications where port matching is required.

N1811TL

Terminated latching

The N1811TL is a terminated bypass switch available in the frequency range from dc to 26.5 GHz. The switch's internal load can terminate the device under test when in the bypass mode (up to 1 watt). Because of its compact design, it is ideal for drop-in, drop-out applications.

N1812UL

Unterminated latching

The N1812UL is a versatile, unterminated 5-port switch available in the frequency range from dc to 26.5 GHz. In transfer switch applications, the fifth port can be terminated externally with a high-power termination. It can also be utilized for signal path reversal or as a calibration port.

Technology

Agilent Technologies switches are designed with a rectangular coaxial structure similar to edge-line. This transmission line structure provides for movement of the edge-line center conductor between two fixed, continuous ground planes. The main advantage of this innovation is that the moving contacts can be easily activated, yet maintain high-isolation and low-insertion loss.

The RF contact configuration is designed for controlled wiping action. Since the outer conductor is not part of the switching function, repeatability and life are improved. The switching action occurs typically within 15 milliseconds, after which permanent magnets latch the contacts to retain the new switch position.

Operation

All switches are "break before make": the switched ports are not connected to each other. This prevents damage to sensitive circuits and enhances test simplicity.

Driving

There are two positions for the N181x family of switches. Standard switching is accomplished by applying the supply voltage to pin 5 (+V) and grounding either pin 4 (A) or pin 3 (B) to actuate the mechanism to the desired state. See page 5, pin-out diagram.

Warning minimum switch spacing is 6.0 mm (0.25 inch).

When option 403 is added, the drive current is automatically disconnected after the switch is fully latched (15ms). Without option 403, the **switches MUST be actuated using a pulse drive** – the switches are not designed to withstand continuous current. In this case, the pulse duration must be at least 15ms to ensure that the switch will fully latch.

Option 401 drives the switch with TTL/5V CMOS compatible logic, which controls the DC power supply to drive the switch.

Option 402 provides electronic indication of switch state. The circuitry consists of two independent commons, which can be connected to outputs corresponding to either position A or B. Because the commons are electrically isolated from each other as well as the drive circuit, this option allows two position signals to be obtained.

Specifications

Specifications describe the instrument's warranted performance. **Supplemental and typical characteristics** are intended to provide information useful in applying the instrument by giving typical, but not warranted performance parameters.

General

Input power (into load)	1 W, 7 V dc, 50 W pk, 10 μs max pulse duration, not to exceed 1 W avg
Input power (into thru)	2 W, 7 V dc, 50 W pk, 10 μs max pulse duration, not to exceed 2 W avg
Coil voltage	5, 15, 24 VDC

Standard performance specifications - N181x series

$$\text{Isolation (dB)} = 90 - \left(\frac{30}{26.5}\right) F, \text{ where } F \text{ is specified in GHz}$$

dc	4 GHz	12.4 GHz	20 GHz	26.5 GHz
90	85	76	67	60

$$\text{Insertion loss (dB)} = 0.35 + \left(\frac{.45}{26.5}\right) F, \text{ where } F \text{ is specified in GHz}$$

dc	4 GHz	12.4 GHz	20 GHz	26.5 GHz
0.35	0.42	0.56	0.69	0.80

SWR	dc-4 GHz	4-12.4 GHz	12.4-20 GHz	20-26.5 GHz
	1.15	1.25	1.30	1.60

Optional high-performance specifications - N181x series

$$\text{Isolation (dB)} = 125 - \left(\frac{35}{26.5}\right) F, \text{ where } F \text{ is specified in GHz}$$

	dc	4 GHz	12.4 GHz	20 GHz	26.5 GHz
Option 301¹	125	120	109	99	90

$$\text{Insertion loss (dB)} = 0.20 + \left(\frac{.45}{26.5}\right) F, \text{ where } F \text{ is specified in GHz}$$

	dc	4 GHz	12.4 GHz	20 GHz	26.5 GHz
Option 302	0.15	0.27	0.41	0.53	0.65

SWR	dc-4 GHz	4-12.4 GHz	12.4-20 GHz	20-26.5 GHz
Option 302	1.10	1.20	1.23	1.45

- Option 301:
Environmental: storage and cycling temperature: -55C to +65 C
Environmental: operating temperature: -25C to +65C

N1810UL

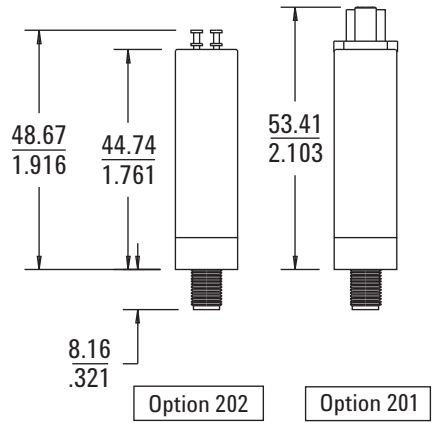
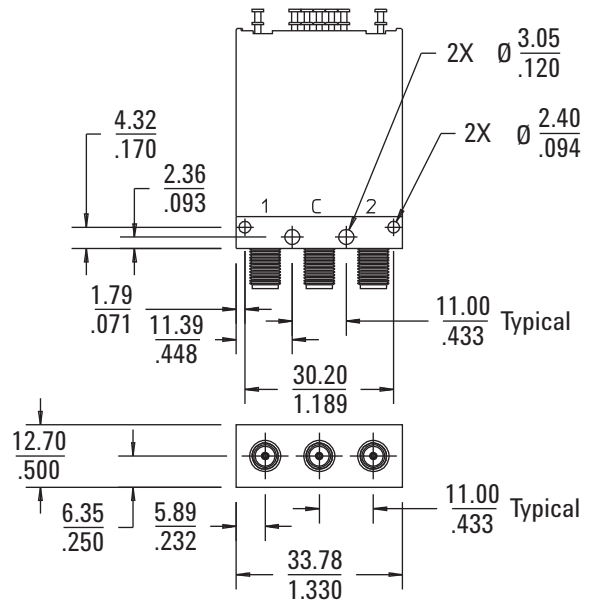
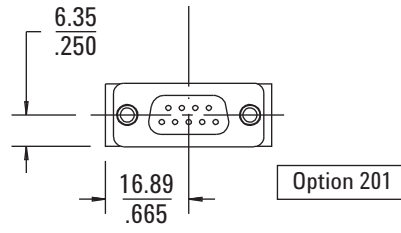
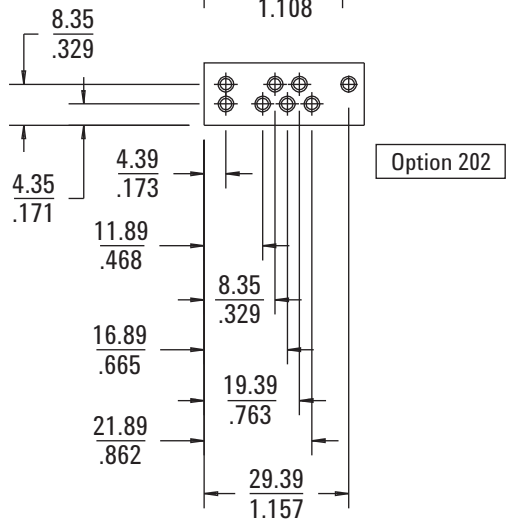
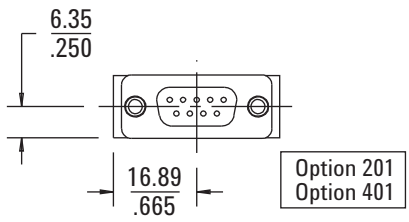
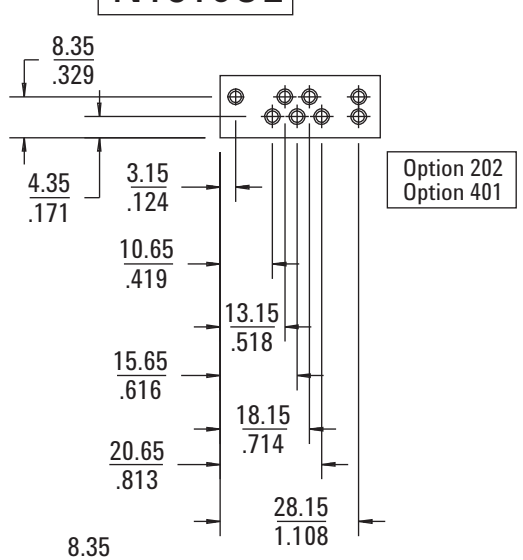

N1810UL

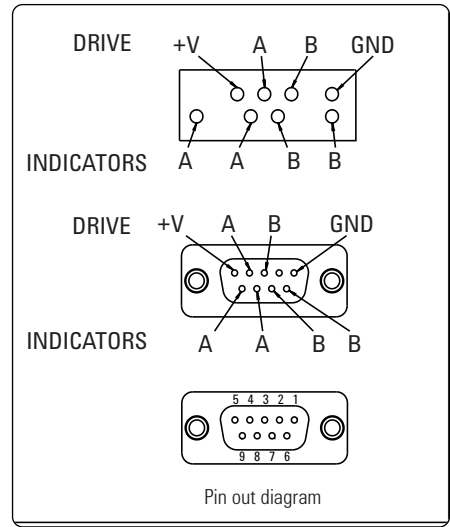
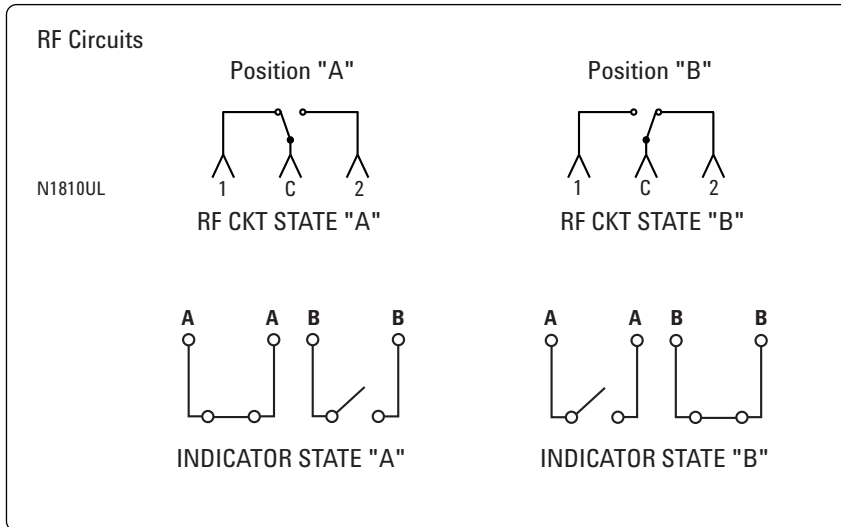

Switch drive specifications N1810UL

Option	Parameter	Conditions	min	nominal	max	Units
105	Supply voltage supply current	Supply voltage = 5 V	4.5	5 300	7.0	V mA
115 ¹	Supply voltage Supply current	Supply voltage = 15 V	12.0	15 125	20.0	V mA
124 ²	Supply voltage Supply current	Supply voltage = 24 V	20.0	24 75	32.0	V mA

TTL Drive specifications

Option	Parameter	Conditions	min	nominal	max	Units
401	High level input		3.0		12.0	V
	Low level input		0.0		1.0	V
	Max input current	input voltage = 12.0 V input voltage = 3.85 V		0.25	1.0 0.5	mA mA

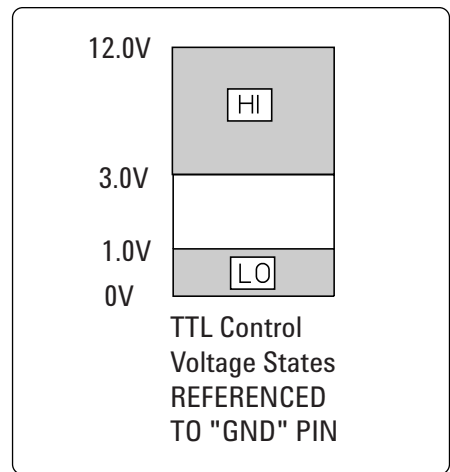

Driving the switch*

STD drive		TTL drive Connect GND to ground		RF State	INDICATOR State
A	B	A	B		
GND	OPEN	Hi	Lo	"A"	"A"
OPEN	GND	Lo	Hi	"B"	"B"
GND	GND	Hi	Hi	Switching Disabled **	NA
OPEN	OPEN	Lo	Lo	Switching Disabled **	NA

GND: +V - Vsupply (see switch drive specification table, this page)

OPEN* +V to +v - 1.5 volts

Hi 3.0 V to 12.0 V

Lo 0.0 V to 1.0 V Warning Drive level below -25 V will damage TTL drive circuit!

* WARNING! Use adapter cable 11764-60011 with 87130A switch driver

** WARNING! Driving both select lines will disable switch (see troubleshoot guide)

WARNING! Minimum switch spacing 6.0 mm (0.25 inch)

- Option 115: Characteristic Life: 5 million cycles minimum, except 1 million cycles minimum when driven at voltages 18-20 Vdc.
- Option 124: Characteristic Life: 5 million cycles minimum, except 1 million cycles minimum when driven at voltages 28-32 Vdc.

N1810TL

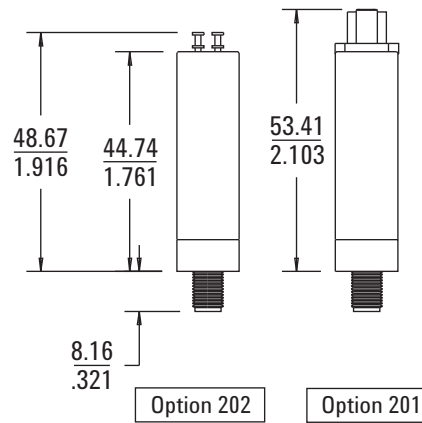
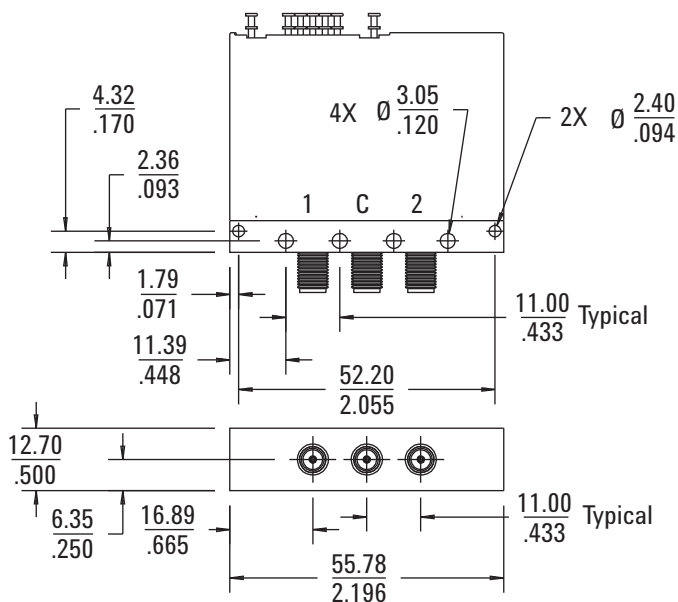
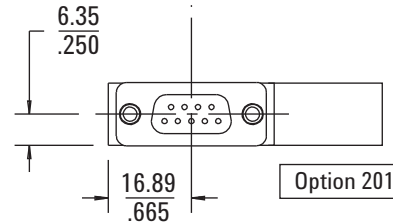
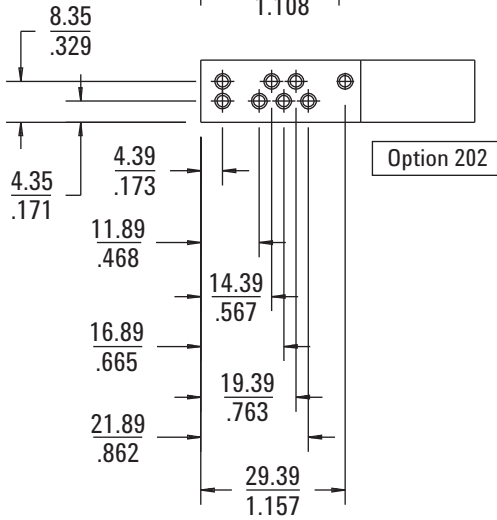
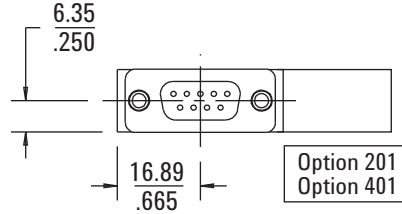
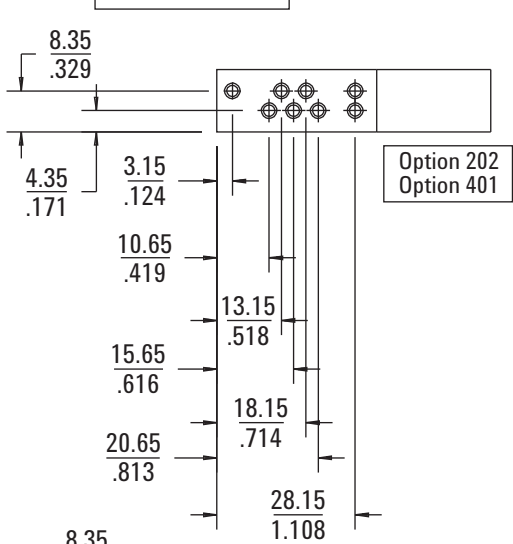

N1810TL

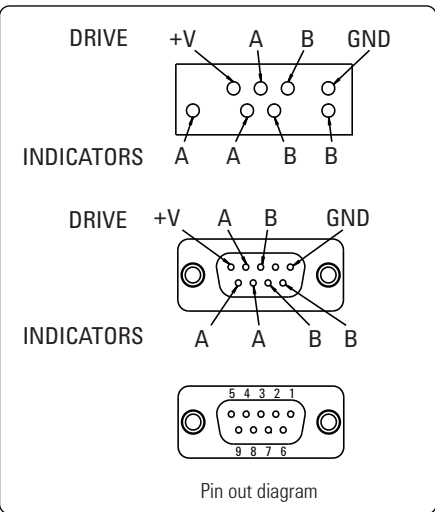
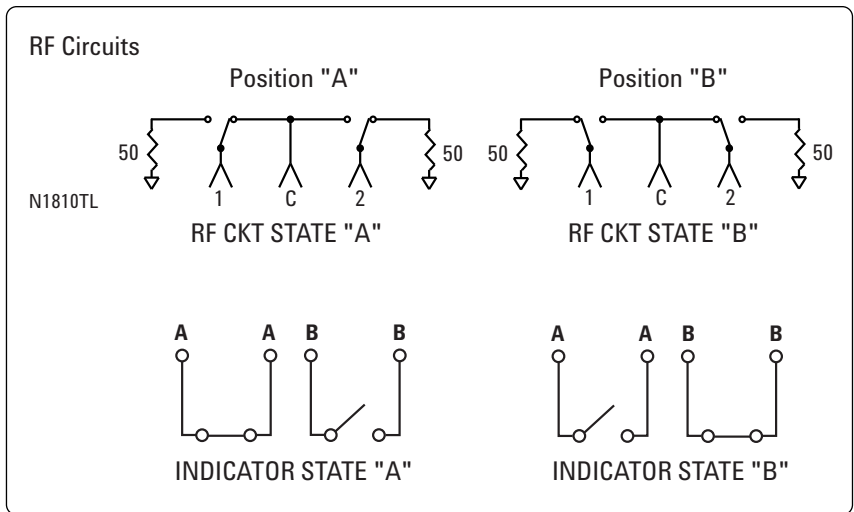

Switch drive specifications N1810TL, N1811TL, N1812UL

Option	Parameter	Conditions	min	nominal	max	Units
105	Supply voltage supply current	Supply voltage = 5 V	4.5	5 600	7.0	V mA
115 ¹	Supply voltage Supply current	Supply voltage = 15 V	12.0	15 250	20.0	V mA
124 ²	Supply voltage Supply current	Supply voltage = 24 V	20.0	24 150	32.0	V mA

TTL Drive specifications

Option	Parameter	Conditions	min	nominal	max	Units	
401	High level input		3.0		12.0	V	
	Low level input		0.0		1.0	V	
	Max input current	input voltage = 12.0 V				1.0	mA
		input voltage = 3.85 V		0.25		0.5	mA

Driving the switch*

STD drive		TTL drive Connect GND to ground		RF State	INDICATOR State
A	B	A	B		
GND	OPEN	Hi	Lo	"A"	"A"
OPEN	GND	Lo	Hi	"B"	"B"
GND	GND	Hi	Hi	Switching Disabled **	NA
OPEN	OPEN	Lo	Lo	Switching Disabled **	NA

GND: +V - Vsupply (see switch drive specification table, this page)

OPEN* +V to +v - 1.5 volts

Hi 3.0 V to 12.0 V

Lo 0.0 V to 1.0 V Warning Drive level below -25 V will damage TTL drive circuit!

* WARNING! Use adapter cable 11764-60011 with 87130A switch driver

** WARNING! Driving both select lines will disable switch (see troubleshoot guide)

WARNING! Minimum switch spacing 6.0 mm (0.25 inch)

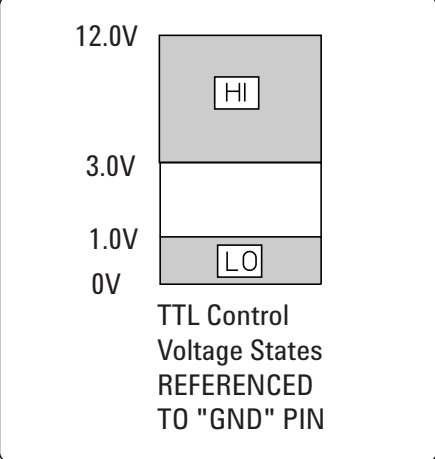

- Option 115: Characteristic Life: 5 million cycles minimum, except 1 million cycles minimum when driven at voltages 18-20 Vdc.
- Option 124: Characteristic Life: 5 million cycles minimum, except 1 million cycles minimum when driven at voltages 28-32 Vdc.

N1811TL

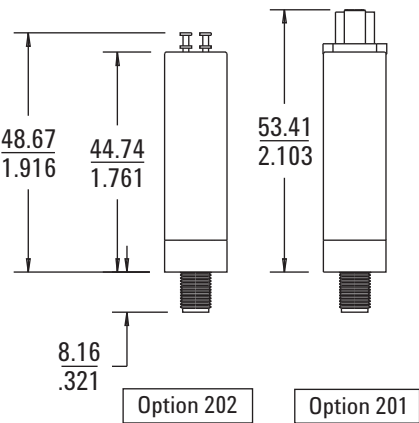
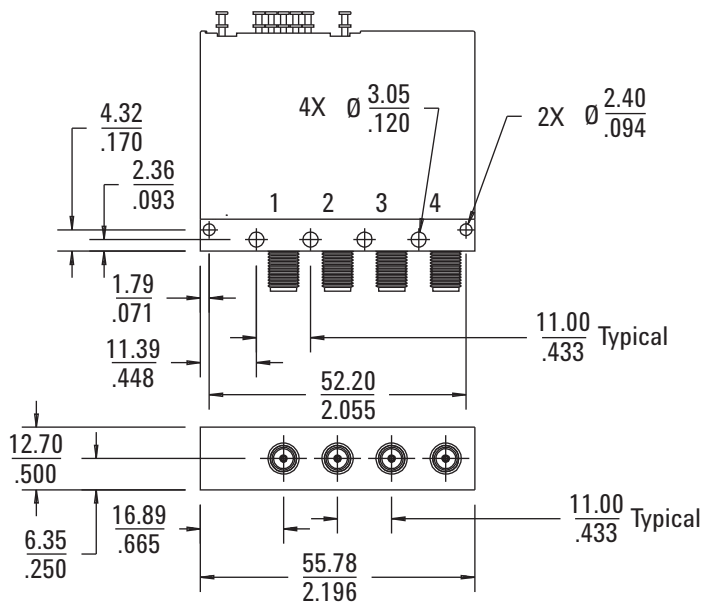
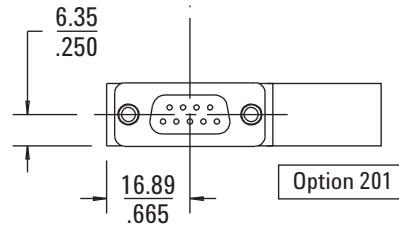
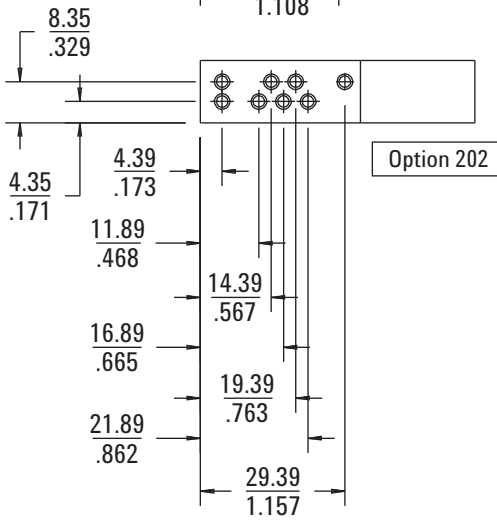
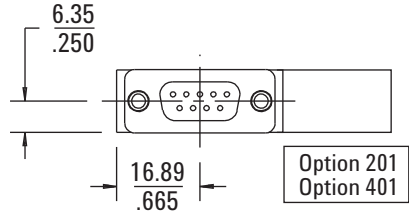
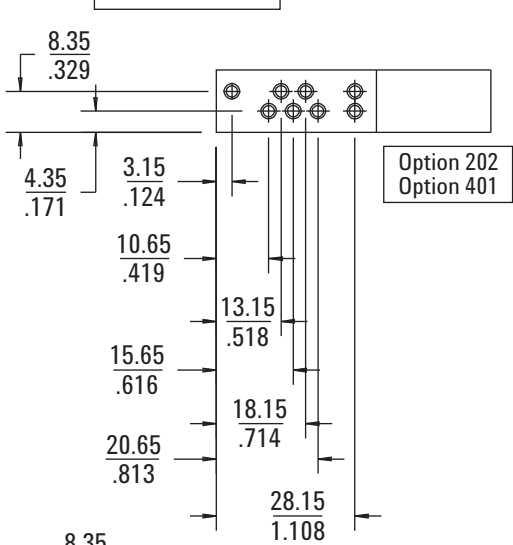

N1811TL

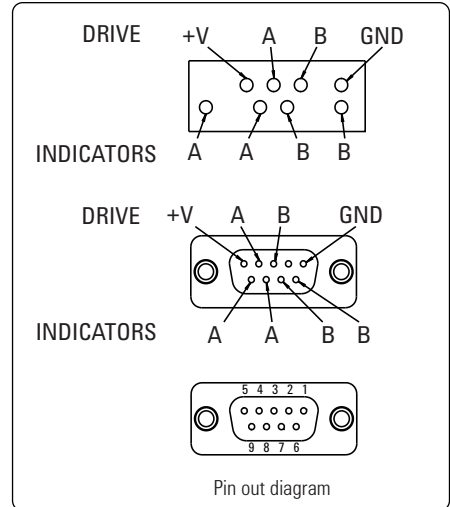
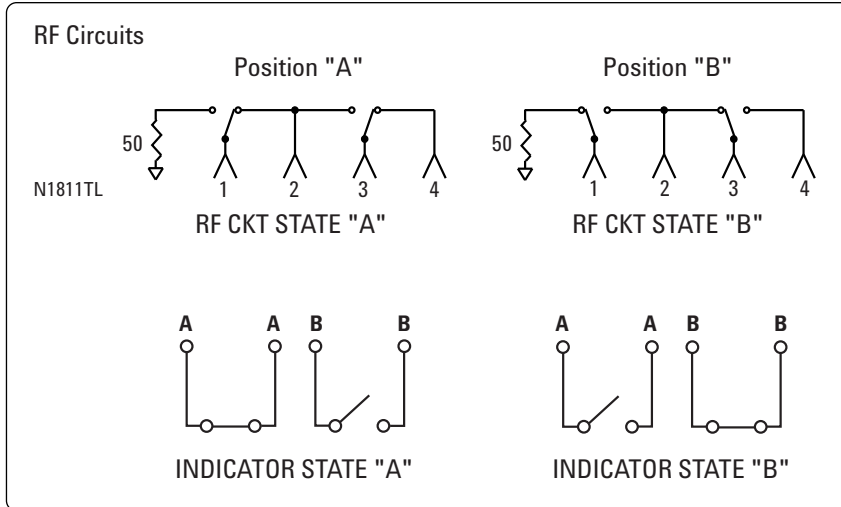

Switch drive specifications N1810TL, N1811TL, N1812UL

Option	Parameter	Conditions	min	nominal	max	Units
105	Supply voltage supply current	Supply voltage = 5 V	4.5	5 600	7.0	V mA
115 ¹	Supply voltage Supply current	Supply voltage = 15 V	12.0	15 250	20.0	V mA
124 ²	Supply voltage Supply current	Supply voltage = 24 V	20.0	24 150	32.0	V mA

TTL Drive specifications

Option	Parameter	Conditions	min	nominal	max	Units
401	High level input		3.0		12.0	V
	Low level input		0.0		1.0	V
	Max input current	input voltage = 12.0 V			1.0	mA
		input voltage = 3.85 V		0.25	0.5	mA

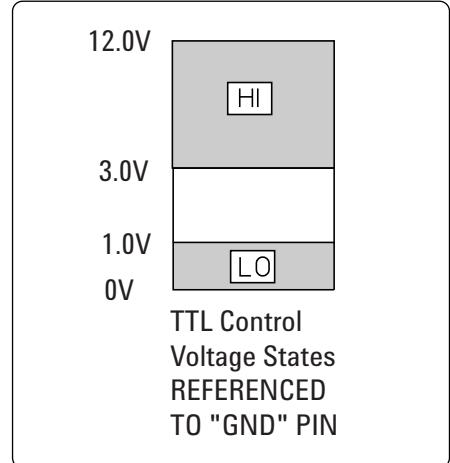

Driving the switch*

STD drive		TTL drive Connect GND to ground		RF State	INDICATOR State
A	B	A	B		
GND	OPEN	Hi	Lo	"A"	"A"
OPEN	GND	Lo	Hi	"B"	"B"
GND	GND	Hi	Hi	Switching Disabled **	NA
OPEN	OPEN	Lo	Lo	Switching Disabled **	NA

- GND: +V - Vsupply (see switch drive specification table, this page)
 OPEN* +V to +v - 1.5 volts
 Hi 3.0 V to 12.0 V
 Lo 0.0 V to 1.0 V Warning Drive level below -25 V will damage TTL drive circuit!
 * WARNING! Use adapter cable 11764-60011 with 87130A switch driver
 ** WARNING! Driving both select lines will disable switch (see troubleshoot guide)
 WARNING! Minimum switch spacing 6.0 mm (0.25 inch)

- Option 115: Characteristic Life: 5 million cycles minimum, except 1 million cycles minimum when driven at voltages 18-20 Vdc.
- Option 124: Characteristic Life: 5 million cycles minimum, except 1 million cycles minimum when driven at voltages 28-32 Vdc.

N1812UL

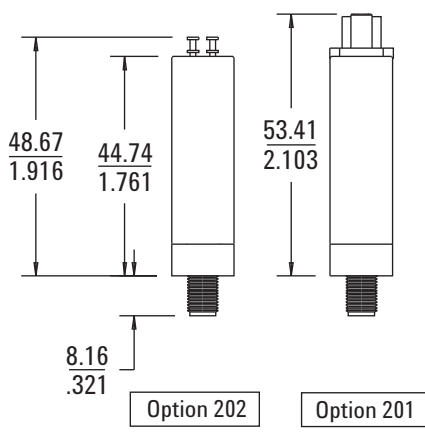
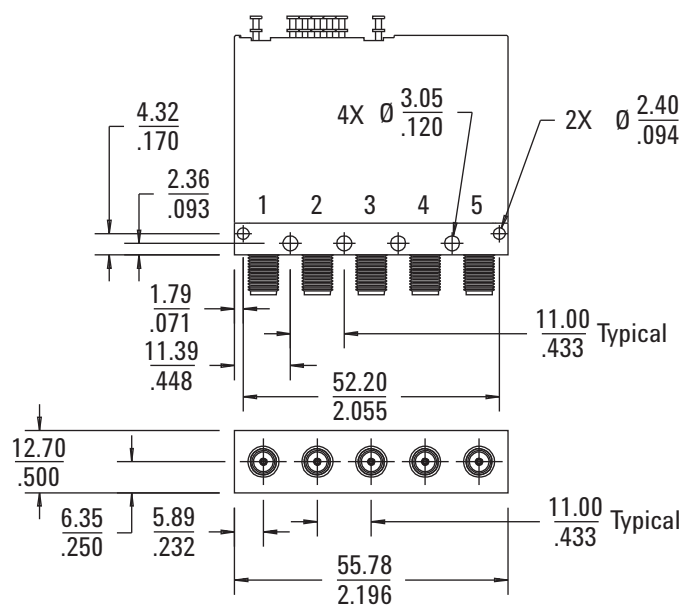
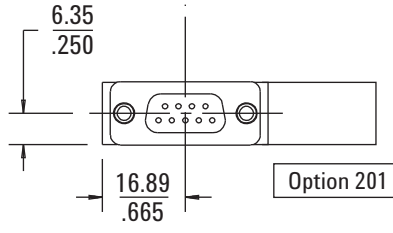
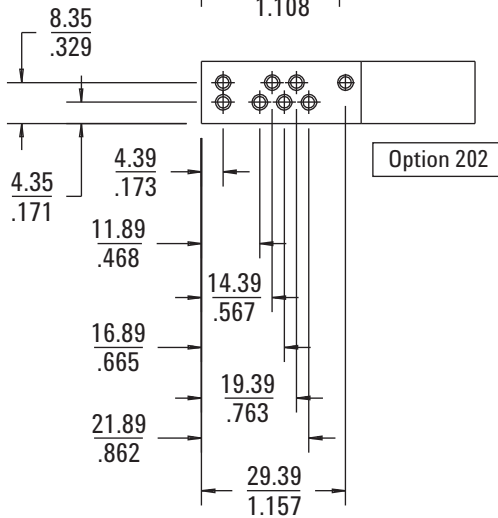
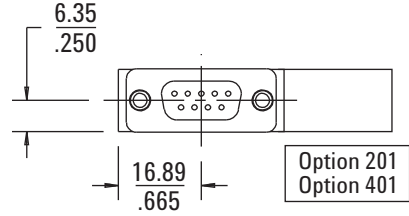
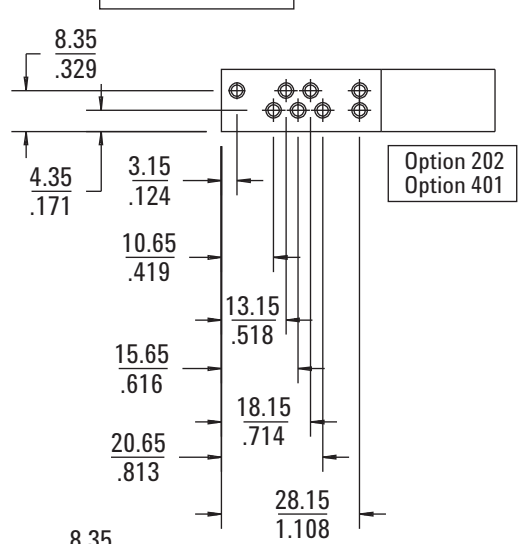

N1812UL

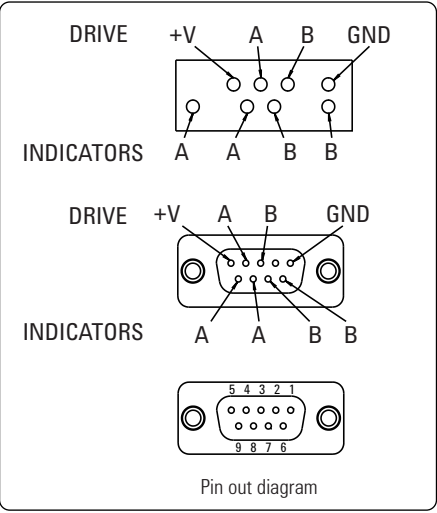
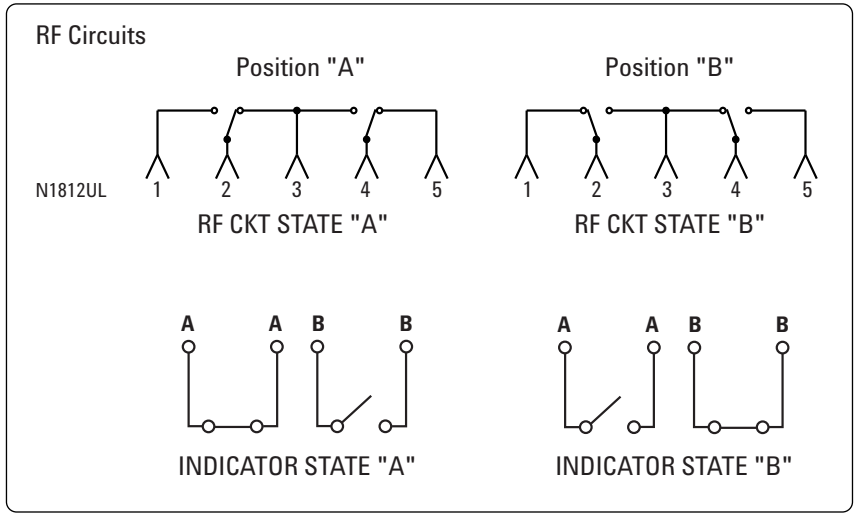

Switch drive specifications N1810TL, N1811TL, N1812UL

Option	Parameter	Conditions	min	nominal	max	Units
105	Supply voltage	Supply voltage = 5 V	4.5	5	7.0	V
	supply current			600		mA
115 ¹	Supply voltage	Supply voltage = 15 V	12.0	15	20.0	V
	Supply current			250		mA
124 ²	Supply voltage	Supply voltage = 24 V	20.0	24	32.0	V
	Supply current			150		mA

TTL Drive specifications

Option	Parameter	Conditions	min	nominal	max	Units
401	High level input	input voltage = 12.0 V input voltage = 3.85 V	3.0		12.0	V
	Low level input		0.0		1.0	V
	Max input current				0.25	1.0
					0.5	mA

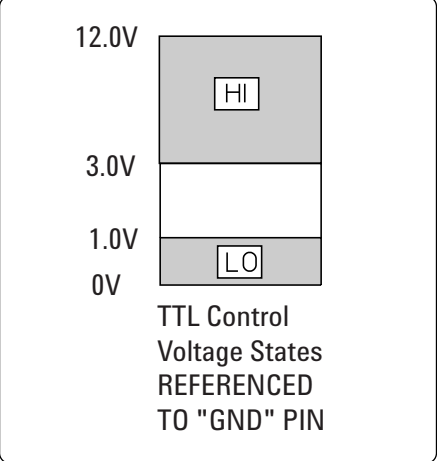

Driving the switch*

STD drive		TTL drive Connect GND to ground		RF State	INDICATOR State
A	B	A	B		
GND	OPEN	Hi	Lo	"A"	"A"
OPEN	GND	Lo	Hi	"B"	"B"
GND	GND	Hi	Hi	Switching Disabled **	NA
OPEN	OPEN	Lo	Lo	Switching Disabled **	NA

GND: +V - Vsupply (see switch drive specification table, this page)

OPEN* +V to +v - 1.5 volts

Hi 3.0 V to 12.0 V

Lo 0.0 V to 1.0 V Warning Drive level below -25 V will damage TTL drive circuit!

* WARNING! Use adapter cable 11764-60011 with 87130A switch driver

** WARNING! Driving both select lines will disable switch (see troubleshoot guide)

WARNING! Minimum switch spacing 6.0 mm (0.25 inch)

1. Option 115: Characteristic Life: 5 million cycles minimum, except 1 million cycles minimum when driven at voltages 18-20 Vdc.

2. Option 124: Characteristic Life: 5 million cycles minimum, except 1 million cycles minimum when driven at voltages 28-32 Vdc.

Supplemental Characteristics

General operating characteristics - N181x series

Switching speed	Repeatability	Life ^{1,2}	Impedance
< 15 ms	< .03 dB	> 5 million cycles	50 ohms

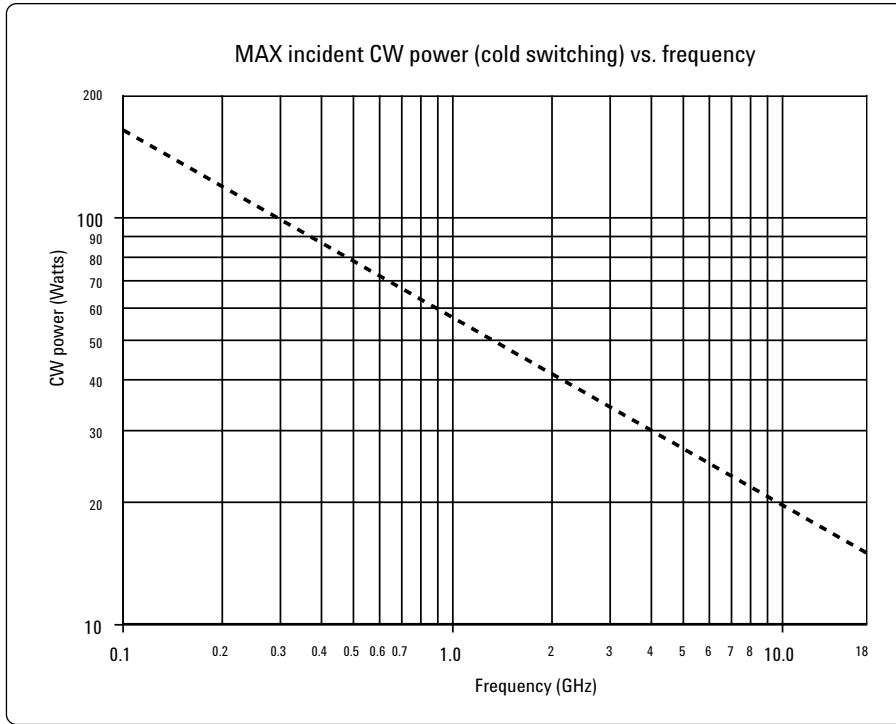

Reference conditions:

- Cold switching only (NO Hot switching)
- Ambient temperature of 75°C or less³
- Sea level (0.88 derating @ 15,000 ft.)
- Load VSWR < 1.2 (see graph for derating above 1.2 VSWR)

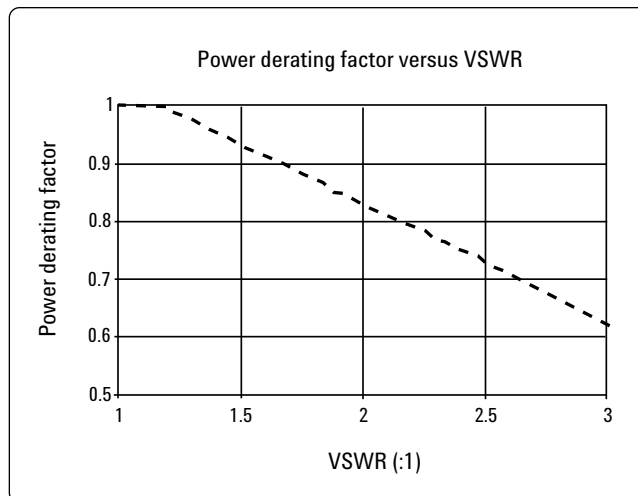

1. Option 115: Characteristic Life: 5 million cycles minimum, except 1 million cycles minimum when driven at voltages 18-20 Vdc.
2. Option 124: Characteristic Life: 5 million cycles minimum, except 1 million cycles minimum when driven at voltages 28-32 Vdc.
3. Option 301:
 - Environmental: storage and cycling temperature: -55C to +65 C
 - Environmental: operating temperature: -25C to +65

Environmental

The switch is designed to fully comply with Agilent Technologies' product operating environment specifications. The following summarizes the environmental specifications for these products (Class B1).

Temperature¹:

Operating:	-25 to +75°C
Storage:	-55 to +85°C
Cycling:	-55 to +85°C, 10 cycles per MIL-STD 202F, 170D, Condition A (modified)

Vibration:

Operating:	7 g, 5-2000 Hz @ 0.25 in. p-p
Survival:	20 g, 20-2000 Hz @ 0.06 in. p-p, 4min/cycle, 4cycles/axis
Random:	2.41 g (rms.) 10min/axis
Shock:	Half sine: 500 g @ 0.5 ms, 3 drops/direction, 18 total
Operating:	50g @ 6 ms, 6 directions

Humidity:

Operating:	15 to 95 % relative humidity
Storage:	65°C, 95 % RH, 10 days, MIL-STD 202F, Method 106E

Altitude:

Operating:	15,000 feet / 4.6 km
Storage:	50,000 feet / 15.3 km, MIL-STD 202F, Method 105C, Condition B

Troubleshoot Guide

Probable cause	Test	Allowable range		Remedy
		Low value	High Value	
Not connected to supply		See Drive Specifications		Connect +V to power supply
Supply not turned on				Turn on power supply
Supply voltage less than minimum	Measure voltage from control pin to +V	See Drive Specifications		
Supply current low	Measure current draw with drive pin selected	See Drive Specifications		Increase drive voltage or reduce drive line resistance
OPEN state voltage too low	Measure voltage from control pin to +V	(+V-1.5) volts	+V volts	
Select lines not at ground (STD DRIVE)	Measure voltage from drive select pin to ground			Eliminate ground loops and lead high resistance
TTL "LOW" voltage too high	Measure voltage from ground pin to TTL drive pin	See Drive Specifications		Connect ground pin to ground
TTL "LOW" voltage < 0.0 volts	Measure voltage from ground pin to TTL drive pin	See Drive Specifications		Eliminate ground loops
TTL GND pin not grounded				Connect GND pin to ground
Driving switch with 87130A				Use adapter cable 11764-60011

1. Option 301:
 Environmental: storage and cycling temperature: -55C to +65 C
 Environmental: operating temperature: -25C to +65C

Ordering information

Required - Specify one model number, one frequency range, one coil voltage, and one DC connector type (**must select one of each**)

Optional - Specify RF performance enhancements and drive options (**may select any, all, or none**)

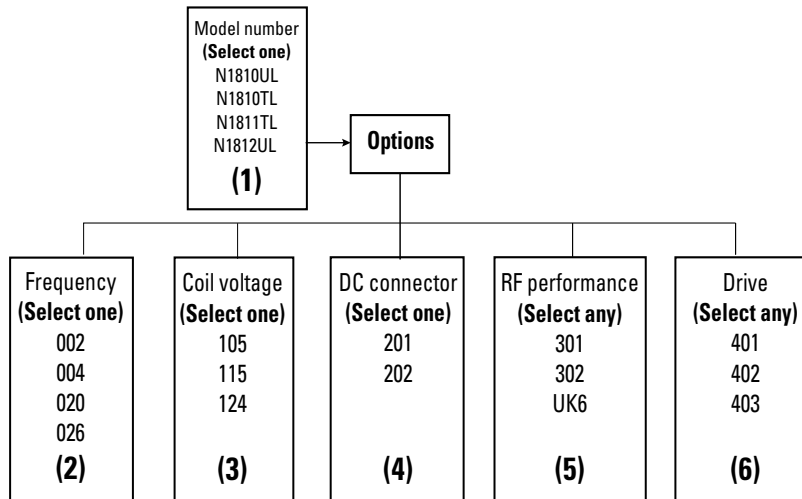

(1) Select a model to fit your application. (Required)

N1810UL – Unterminated latching 3-port
 N1810TL – Terminated latching 3-port
 N1811TL – Terminated latching 4-port
 N1812UL – Unterminated latching 5-port

(2) Select a frequency range. (Required)

002 - DC to 2 GHz
 004 - DC to 4 GHz
 020 - DC to 20 GHz
 026 - DC to 26.5 GHz

(3) Select a coil voltage level. (Required)

105* – 5 volts
 115 – 15 volts
 124 – 24 volts

(4) Select a DC connector type. (Required)

201 – “D” subminiature 9 pin female
 202 – Solder lugs

(5) Select RF performance enhancements. (Optional)

301 – Increased isolation
 302 – Reduced standing wave ratio and insertion loss
 UK6 – Calibration certificate with test data

(6) Select drive options. (Optional)

401 – TTL/CMOS compatible 5v drive
 402 – Position indicators
 403 – Current interrupts

Ordering example:

For an unterminated 5 port switch, operating up to 20 GHz, with 15 volt coils, D-sub connector, high isolation, and TTL, the order should look as follows:
 N1812UL Opt 020 115 201 301 401

*Includes options 402 and 403

Agilent Technologies' Test and Measurement Support, Services, and Assistance

Agilent Technologies aims to maximize the value you receive, while minimizing your risk and problems. We strive to ensure that you get the test and measurement capabilities you paid for and obtain the support you need. Our extensive support resources and services can help you choose the right Agilent products for your applications and apply them successfully. Every instrument and system we sell has a global warranty. Support is available for at least five years beyond the production life of the product. Two concepts underlie Agilent's overall support policy: "Our Promise" and "Your Advantage."

Our Promise

Our Promise means your Agilent test and measurement equipment will meet its advertised performance and functionality. When you are choosing new equipment, we will help you with product information, including realistic performance specifications and practical recommendations from experienced test engineers. When you use Agilent equipment, we can verify that it works properly, help with product operation, and provide basic measurement assistance for the use of specified capabilities, at no extra cost upon request. Many self-help tools are available.

Your Advantage

Your Advantage means that Agilent offers a wide range of additional expert test and measurement services, which you can purchase according to your unique technical and business needs. Solve problems efficiently and gain a competitive edge by contracting with us for calibration, extra-cost upgrades, out-of-warranty repairs, and on-site education and training, as well as design, system integration, project management, and other professional engineering services. Experienced Agilent engineers and technicians worldwide can help you maximize your productivity, optimize the return on investment of your Agilent instruments and systems, and obtain dependable measurement accuracy for the life of those products.

By internet, phone, or fax, get assistance with all your test and measurement needs.

Online assistance:

www.agilent.com/find/assist

Phone or Fax

United States:

(tel) 1 800 452 4844

Canada:

(tel) 1 877 894 4414

(fax) (905) 282 6495

China:

(tel) 800 810 0189

(fax) 1 0800 650 0121

Europe:

(tel) (31 20) 547 2323

(fax) (31 20) 547 2390

Latin America:

(tel) (305) 269 7500

(fax) (305) 269 7599

Product specifications and descriptions in this document subject to change without notice.

© Agilent Technologies, Inc. 2001

Printed in USA, June 10', 2002

5968-9653E

MS-DOS® is a U.S. registered trademark of Microsoft Corp.



Agilent Technologies