

11612B
Bias Network

Operating and Service
Manual



Agilent Part Number: 11612-90005
Printed in USA
March 2001
Supersedes: June 1999

Notice

The information contained in this document is subject to change without notice.

Agilent makes no warranty of any kind with regard to this material, including, but not limited to, the implied warranties of merchantability and fitness for a particular purpose. Agilent shall not be liable for errors contained herein or for incidental or consequential damages in connection with the furnishing, performance, or use of this material.

Agilent assumes no responsibility for the use or reliability of its software on equipment that is not furnished by Agilent.

This document contains proprietary information which is protected by copyright. All rights are reserved. No part of this document may be photocopied, reproduced, or translated to another language without prior written consent of Agilent Technologies.

Restricted Rights Legend

Use, duplication, or disclosure by the U.S. Government is subject to restrictions as set forth in subparagraph (c)(1)(ii) of the Rights in Technical Data and Computer Software clause at DFARS 252.227-7013 for DOD agencies, and subparagraphs (c)(1) and (c)(2) of the Commercial Computer Software Restricted Rights clause at FAR 52.227-19 for other agencies.

Agilent Technologies, Inc
Santa Rosa Systems Division
1400 Fountaingrove Parkway
Santa Rosa, CA 95403-1799, U.S.A.

© Copyright 1989, 1999, 2001 Agilent Technologies, Inc.

Warranty

Certification

Agilent Technologies certifies that this product met its published specifications at the time of shipment from the factory. Agilent Technologies, further certifies that its calibration measurements are traceable to the United States National Institute of Standards and Technology (NIST, formerly NBS), to the extent allowed by the Institute's calibration facility, and to the calibration facilities of other International Standards Organization members.

Warranty

This Agilent Technologies system product is warranted against defects in materials and workmanship for a period corresponding to the individual warranty periods of its component products. Instruments are warranted for a period of one year. During the warranty period, Agilent Technologies will, at its option, either repair or replace products that prove to be defective.

Warranty service for products installed by Agilent and certain other products designated by Agilent will be performed at Buyer's facility at no charge within Agilent service travel areas. Outside Agilent service travel areas, warranty service will be performed at Buyer's facility only upon Agilent's prior agreement and Buyer shall pay Agilent's round trip travel expenses. In all other areas, products must be returned to a service facility designated by Agilent.

For products returned to Agilent for warranty service, Buyer shall prepay shipping charges to Agilent and Agilent shall pay shipping charges to return the product to Buyer. However, Buyer shall pay all shipping charges, duties, and taxes for products returned to Agilent from another country.

Agilent warrants that its software and firmware designated by Agilent for use with an instrument will execute its programming instructions when properly installed on that instrument. Agilent does not warrant that the operation of the instrument, or software, or firmware will be uninterrupted or error free.

LIMITATION OF WARRANTY. The foregoing warranty shall not apply to defects resulting from improper or inadequate maintenance by Buyer, Buyer-supplied software or interfacing, unauthorized modification or misuse, operation outside of the environmental specifications for the product, or improper site preparation or maintenance.

NO OTHER WARRANTY IS EXPRESSED OR IMPLIED. AGILENT SPECIFICALLY DISCLAIMS THE IMPLIED WARRANTIES OR MERCHANTABILITY AND FITNESS FOR A PARTICULAR PURPOSE.

EXCLUSIVE REMEDIES. THE REMEDIES PROVIDED HEREIN ARE BUYER'S SOLE AND EXCLUSIVE REMEDIES. AGILENT SHALL NOT BE LIABLE FOR ANY DIRECT, INDIRECT, SPECIAL, INCIDENTAL, OR CONSEQUENTIAL DAMAGES, WHETHER BASED ON CONTRACT, TORT, OR ANY OTHER LEGAL THEORY.

Assistance

Product maintenance agreements and other customer assistance agreements are available for Agilent Technologies products.

For assistance, call your local Agilent Technologies Sales and Service Office (refer to [“Service and Support”](#) on page v).

Service and Support

UNITED STATES		
Instrument Support Center Agilent Technologies (800) 403-0801		
EUROPEAN FIELD OPERATIONS		
Headquarters Agilent Technologies S.A. 150, Route du Nant-d'Avril 1217 Meyrin 2/ Geneva Switzerland (41 22) 780.8111	France Agilent Technologies France 1 Avenue Du Canada Zone D'Activite De Courtaboeuf F-91947 Les Ulis Cedex France (33 1) 69 82 60 60	Germany Agilent Technologies GmbH Agilent Technologies Strasse 61352 Bad Homburg v.d.H Germany (49 6172) 16-0
Great Britain Agilent Technologies Ltd. Eskdale Road, Winnersh Triangle Wokingham, Berkshire RG41 5DZ England (44 118) 9696622		
INTERCON FIELD OPERATIONS		
Headquarters Agilent Technologies 3495 Deer Creek Rd. Palo Alto, CA 94304-1316 USA (415) 857-5027	Australia Agilent Technologies Australia Ltd. 31-41 Joseph Street Blackburn, Victoria 3130 (61 3) 895-2895	Canada Agilent Technologies (Canada) Ltd. 17500 South Service Road Trans-Canada Highway Kirkland, Quebec H9J 2X8 Canada (514) 697-4232
Japan Agilent Technologies Japan, Ltd. Measurement Assistance Center 9-1, Takakura-Cho, Hachioji-Shi, Tokyo 192-8510, Japan TEL (81) -426-56-7832 FAX (81) -426-56-7840	Singapore Agilent Technologies Singapore (Pte.) Ltd. 150 Beach Road #29-00 Gateway West Singapore 0718 (65) 291-9088	Taiwan Agilent Technologies Taiwan 8th Floor, H-P Building 337 Fu Hsing North Road Taipei, Taiwan (886 2) 712-0404
China China Agilent Technologies 38 Bei San Huan X1 Road Shuang Yu Shu Hai Dian District Beijing, China (86 1) 256-6888		

General Information

The 11612B bias network provides a means of supplying dc bias to the center conductor of a coaxial line of a biasable component or device while blocking the dc bias to the RF input port.

Instruments Covered by Manual

Each bias network has a five digit serial number. The contents of this manual apply to bias networks having a serial number with the last five digits 02234 and higher.

Incoming Inspection

If the bias network or its case appear to be damaged, set aside the device and all packaging materials. Contact the nearest Agilent Technologies office listed in [“Service and Support” on page v](#) in the front matter of this manual.

Agilent will arrange for repair or replacement of incomplete or damaged shipments without waiting for a settlement from the transportation company.

Returning for Service

If you need to return the bias network for service, attach a tag indicating the type of service required, your return address, model number, and serial number of the device to be repaired.

Repackaging the device requires original shipping containers and materials or their equivalents. Agilent Technologies can provide packaging materials identical to the original materials. Contact the nearest Agilent office listed in [“Service and Support” on page v](#) in the front matter of this manual.

Preparation for Use

The 11612B bias network is connected in line with the device to be biased. Refer to Figure 2 for a typical test setup. The bias is applied through the SMB snap-on connector. A BNC to SMC adapter cable is included in the 11612B bias network assembly.

Specifications

Specifications describe warranted performance of the device.

Table 1 *Specifications*

Frequency Range		DC Resistance from Bias Port to Output Port (typical)	
0.045 to 50 GHz			
Return Loss (both ports)	Minimum	At 23 °C	.31 ohm
0.045 to 10 GHz	20 dB	At 23 °C, full rated current	.35 ohm
10 to 20 GHz	15 dB	Operating Environment	
20 to 30 GHz	12 dB	Temperature: 0 to +55 °C	
30 to 50 GHz	10 dB	Humidity: Up to 95%	
Insertion Loss	Maximum	Altitude: Up to 7,625 meters (25,000 feet)	
0.045 to 10 GHz	0.8 dB	Storage and Shipment	
10 to 30 GHz	1.5 dB	Temperature: – 40 +75 °C	
30 to 45GHz	2.5 dB	Humidity: Up to 95%	
45 to 50 GHz	3.2 dB	Altitude: Up to 7,625 meters (25,000 feet)	

Supplemental characteristics are non-warranted performance parameters. They are included to provide useful operating information.

Table 2 *Supplemental Characteristics*

Pin depth ¹	0.0000 to 0.076 mm (0.0000 to 0.0030 in)
Impedance	50 ohms, nominal
Maximum bias voltage	±40 Vdc
Maximum bias current	500 mA
Maximum dc leakage current	100 nA
RF connectors	2.4 mm female
Bias connector (non-hermetic)	SMB male
Net weight	0.072 kg (0.158 lb)
Dimensions	50.8 mm x 38 mm x 25.4 mm (2.0 in x 1.5 in x 1.0 in)

1. The electrical performance of the bias network is independent of its pin depth within the range stated above.

Operation

Figure 1 shows a schematic diagram of the bias network. The circuit is a 'tee' in which the capacitor in the left arm acts as a dc block/high pass filter. The vertical arm, with its series inductance and shunt capacitance, acts as a low pass filter.

NOTE

Transistors and negative resistance devices may oscillate if the bias port of the 11612B bias network is not properly terminated.

Agilent recommends that bias from the bias supply be routed through the 11635A bias decoupling network before being applied to the bias port of the 11612B. An adapter cable (part number 5062-4550) is included to connect the bias network and the bias decoupling network.

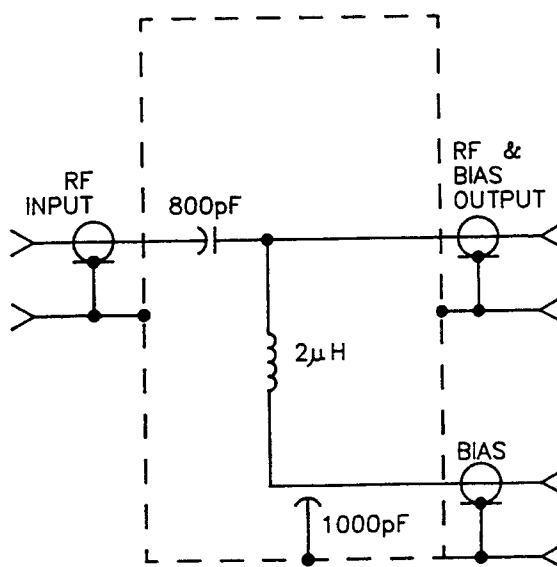

Figure 1 Bias Network Schematic Diagram

Operation

Figure 2 shows the 11612B bias network connected in a typical measurement setup. Although other applications are possible, the general method of setup and operation is the same.

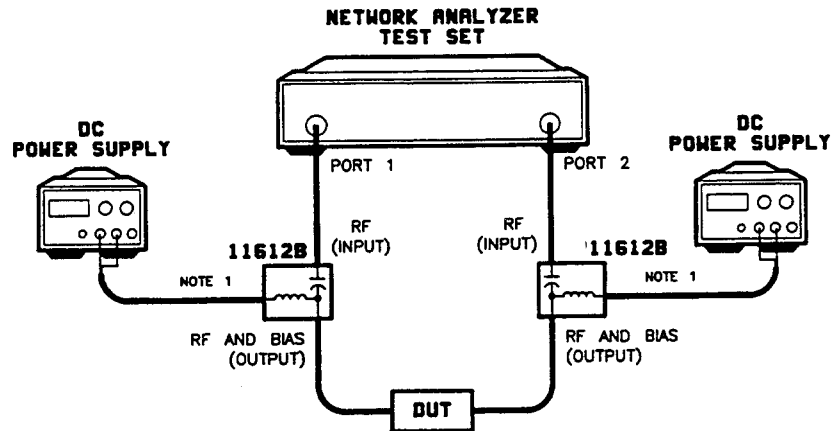

Figure 2 Typical Measurement Setup

Performance Tests

The procedures in this section test the electrical performance of the 11612B using the specifications of Table 1 as performance standards.

Performance may be verified using either a vector or scalar network analyzer setup. Errors due to directivity, source match, and return loss of the ‘opposite port’ termination (and detector match in a scalar system) will add uncertainties to your measurement. The most accurate method uses an error corrected instrument. However, a scalar system will have acceptable results depending on the quality of the components.

Record the results of the performance tests in [Table 3 on page 6](#).

Return Loss of Input and Output Ports

The following instructions apply to both vector and scalar network analyzers.

1. Connect the equipment for a standard reflection measurement.
2. Calibrate the system with an open and a short.
3. Connect the appropriate RF port of the 11612B to the test port. Terminate the opposite port with a 50 ohm load.

NOTE

The return loss of the terminating load should be at least 20 dB better than the desired measurement value.

4. Measure the return loss. The specifications are as follows:

Return Loss (both ports)	Minimum
0.045 to 10 GHz	20 dB
10 to 20 GHz	15 dB
20 to 30 GHz	12 dB
30 to 50 GHz	10 dB

Insertion Loss

1. Connect the equipment for a standard insertion loss measurement.
2. Calibrate the system the system with a through line.
3. Replace the through line with the 11612B bias network.

Performance Tests

4. Measure the insertion loss. The specifications are as follows:

Insertion Loss	Maximum
0.045 to 10 GHz	0.8 dB
10 to 30 GHz	1.5 dB
30 to 45 GHz	2.5 dB
45 to 50 GHz	3.2 dB

Table 3 11612B Performance Test Record

Serial Number _____	Test Date _____
	Tested By _____
Return Loss	Measured Value
Input Port	
0.045 to 10 GHz	_____
10 to 20 GHz	_____
20 to 30 GHz	_____
30 to 50 GHz	_____
Output Port	
0.045 to 10 GHz	_____
10 to 20 GHz	_____
20 to 30 GHz	_____
30 to 50 GHz	_____
Insertion Loss	
0.045 to 10 GHz	_____
10 to 30 GHz	_____
30 to 45 GHz	_____
45 to 50 GHz	_____