

# DAS-1700/1800 Series

High Performance  
ISA-Bus Analog and  
Digital I/O Boards

**FEATURES**

- Family of three data acquisition boards in DAS-1700 Series and four boards in DAS-1800 Series
  - **DAS-1700/1800AO** - 16 single-ended or 8 differential, 12-bit inputs with 2 waveform-quality analog outputs
  - **DAS-1800HC** - 64 single-ended or 32 differential, 12-bit inputs
  - **DAS-1700/1800HR** - 16 single-ended or 8 differential, 16-bit inputs
  - **DAS-1700/1800ST** - 16 single-ended or 8 differential, 12-bit inputs
  - Up to 333 ksamples/s maximum input rate for DAS-1800 Series and up to 160 ksamples/s maximum input rate for DAS-1700 Series
  - Continuous, gap-free, high-speed acquisition under Windows or DOS
  - Channel-gain queue for high-speed acquisition at different gains
  - 1K word FIFO
  - 16-bit DMA transfers with single and dual channel modes
  - Programmable burst mode sampling emulates simultaneous sample-and-hold
  - Pre-, post- and about-triggering
  - 2 waveform-quality analog outputs (DAS-1700/1800AO)
  - 2 DC analog outputs (DAS-1800HC and DAS-1700/1800HR-DA)
  - 4 DC analog outputs (DAS-1700/1800ST-DA)
  - 4 digital outputs (DAS-1700/1800AO, DAS-1700/1800HR and DAS-1700/1800ST),
  - 8 digital outputs (DAS-1800HC), 4 digital inputs (all)
  - Single-slot AT-board plug-in solutions
  - 32-bit DriverLINK software drivers for Windows 95/98/NT/2000 —ActiveX and DLL based
  - Excel Add-In
  - TestPoint drivers and LabVIEW VIs
  - New start-up software included
- APPLICATIONS**
- Product test
  - Process monitoring
  - Data logging

Get "Up & Running" Quickly with Keithley's FREE Bundled Start-Up Software

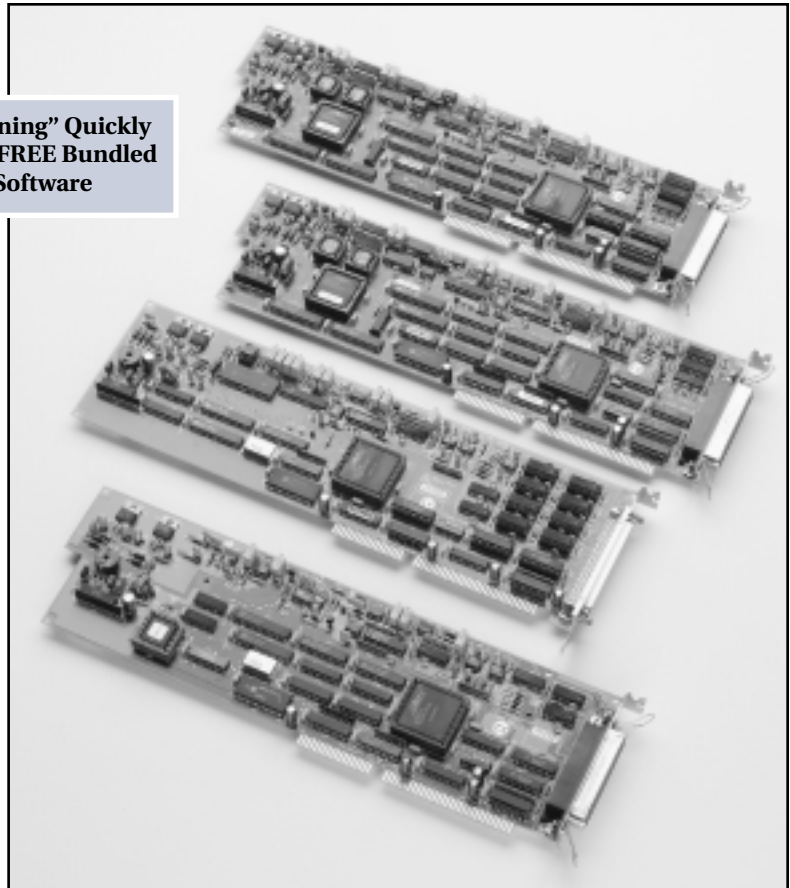

**Block Diagram**

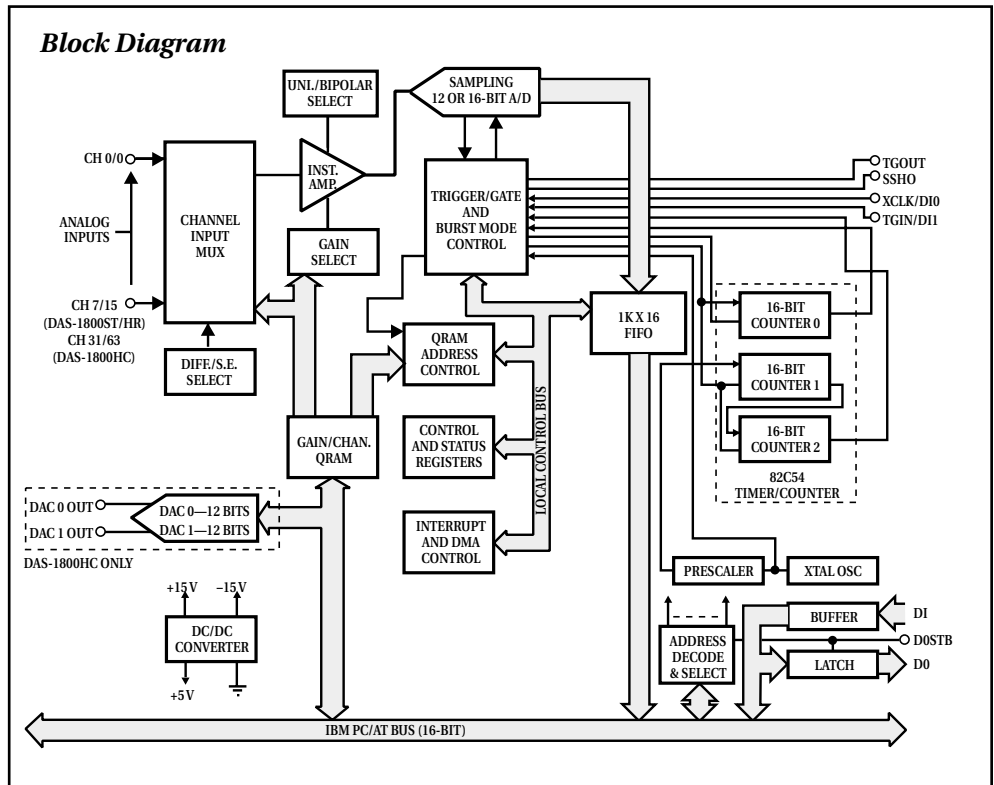

# DAS-1700/1800 Series

## Functional Description

The DAS-1700/1800 Series is a family of high performance data acquisition boards for the IBM PC and compatible computers. All members of the family share a common architecture and core features making each DAS-1700/1800 Series product ideal for high performance applications. Except for the higher sampling rates of the DAS-1800 Series, both product lines are identical in features and performance. However, a high-channel count (HC) board is only available in the DAS-1800 Series.

The DAS-1700/1800 Series features continuous, high speed, gap-free data acquisition under Windows or DOS. An onboard FIFO buffer and dual-channel DMA allow the continuous acquisition of large amounts of data. A gain channel queue lets high speed acquisition continue even on channels with different gains or in non-sequential order. All boards are register compatible. As a result, applications running on one board in the 1700/1800 Series can be ported to another board without changing software.

The DAS-1800HC features 64 single-ended inputs or 32 differential inputs at up to 333 ksamples/s. The DAS-1700/1800ST has 16 single-ended or 8 differential inputs with the ability to externally expand to 256 differential inputs at 333 ksamples/s for the DAS-1800 and at 160

ksamples/s for the DAS-1700. The DAS-1700/1800HR is the 16-bit version of the DAS-1700/1800ST, with a maximum sampling rate of 100 ksamples/s for the DAS-1800 and 50 ksamples/s for the DAS-1700. The DAS-1700/1800AO is the DAS-1700/1800ST with two waveform quality DACs.

The table below outlines the key features of the DAS-1700/1800 Series.

## Analog Inputs

The DAS-1700/1800 Series analog inputs are software-configurable for single-ended or differential inputs and bipolar or unipolar input ranges. The analog inputs are multiplexed into a high-speed 12-bit or 16-bit analog-to-digital converter. The DAS-1700/1800AO, DAS-1700/1800HR, and DAS-1700/1800ST provide 16 single-ended or 8 differential inputs. These six boards also provide a remote ground connection for the analog inputs by a user common mode pin, enabling 16 pseudo-differential inputs. The DAS-1800HC has 64 single-ended or 32 differential inputs.

The DAS-1700/1800AO, DAS-1800HC, and DAS-1700/1800ST have two models. The Model 01 (high gain option) has software-programmable gains of 1, 5, 50, and 250 allowing analog input ranges from  $\pm 20\text{mV}$  to  $\pm 5\text{V}$ .

## DAS-1700/1800 SERIES SELECTOR GUIDE

	DAS-1700/1800AO	DAS-1800HC	DAS-1700/1800HR	DAS-1700/1800ST
<b>Analog Inputs</b>	16 single-ended or 8 differential	64 single-ended or 32 differential	16 single-ended or 8 differential	16 single-ended or 8 differential
<b>Maximum Sampling Rate</b>				
DAS-1700	160 kS/s	N/A	50 kS/s	160 kS/s
DAS-1800	333 kS/s	333 kS/s	100 kS/s	333 kS/s
<b>Multiple Channel Aggregate Sampling Rate</b>				
DAS-1700	150 kS/s	N/A	46 kS/s	150 kS/s
DAS-1800	312.5 kS/s	312.5 kS/s	98 kS/s	312.5 kS/s
<b>Resolution</b>	12-bits	12-bits	16-bits	12-bits
<b>FIFO</b>	1024 locations	1024 locations	1024 locations	1024 locations
<b>External Expansion at Speed</b>	Up to 256 inputs	N/A	Up to 256 inputs	Up to 256 inputs
<b>Gain-Channel Queue Length</b>	256	64	256	256
<b>Gains</b>				
Model 01	1, 5, 50, 250	1, 5, 50, 250	N/A	1, 5, 50, 250
Model 02	1, 2, 4, 8	1, 2, 4, 8	1, 2, 4, 8	1, 2, 4, 8
<b>Input Ranges - Model 01</b>	$\pm 5\text{V}$ , $\pm 1\text{V}$ , $\pm 100\text{mV}$ , $\pm 20\text{mV}$ 0 - 5V, 0 - 1V, 0 - 100mV, 0 - 20mV	$\pm 5\text{V}$ , $\pm 1\text{V}$ , $\pm 100\text{mV}$ , $\pm 20\text{mV}$ 0 - 5V, 0 - 1V, 0 - 100mV, 0 - 20mV	N/A	$\pm 5\text{V}$ , $\pm 1\text{V}$ , $\pm 100\text{mV}$ , $\pm 20\text{mV}$ 0 - 5V, 0 - 1V, 0 - 100mV, 0 - 20mV
<b>Input Ranges - Model 02</b>	$\pm 10\text{V}$ , $\pm 5\text{V}$ , $\pm 2.5\text{V}$ , $\pm 1.25\text{V}$ 0 - 10V, 0 - 5V, 0 - 2.5V, 0 - 1.25V	$\pm 10\text{V}$ , $\pm 5\text{V}$ , $\pm 2.5\text{V}$ , $\pm 1.25\text{V}$ 0 - 10V, 0 - 5V, 0 - 2.5V, 0 - 1.25V	$\pm 10\text{V}$ , $\pm 5\text{V}$ , $\pm 2.5\text{V}$ , $\pm 1.25\text{V}$ 0 - 10V, 0 - 5V, 0 - 2.5V, 0 - 1.25V	$\pm 10\text{V}$ , $\pm 5\text{V}$ , $\pm 2.5\text{V}$ , $\pm 1.25\text{V}$ 0 - 10V, 0 - 5V, 0 - 2.5V, 0 - 1.25V
<b>D/A Outputs</b>	2 Waveform quality	2	2 optional	4 optional
<b>D/A Update Speed</b>	500 kS/s	500 kS/s	500 kS/s	500 kS/s
<b>D/A FIFO Size</b>	2048 Locations	1 Location	1 Location	1 Location
<b>Digital Inputs</b>	4	4	4	4
<b>Digital Outputs</b>	4	8	4	4

# DAS-1700/1800 Series

Model 02 (low gain option) has software-programmable gains of 1, 2, 4, and 8 allowing input ranges from  $\pm 1.25V$  to  $\pm 10V$ . The DAS-1700/1800HR is available only in the low gain Model 02.

You can sample a single channel at any gain up to 333 ksamples/s for the DAS-1800 and up to 160 ksamples/s for the DAS-1700. For the 12-bit boards, multiple channels can be sampled at aggregate rates up to 312.5 ksamples/s for the DAS-1800 and up to 150 ksamples/s aggregate.

The DAS-1700/1800HR samples a single channel at any gain up to 100 ksamples/s for the DAS-1800 and up to 50 ksamples/s for the DAS-1700. Multiple channels can be sampled at aggregate rates up to 98 ksamples/s for the DAS-1800 and up to 46 ksamples/s aggregate for the DAS-1700. Actual system throughput also will vary with the gain selected as shown in the following charts:

## DAS-1701/1801AO, DAS-1801HC, DAS-1701/1801ST

Gain	Unipolar	Bipolar	Single Channel Throughput*		Aggregate Throughput*	
			DAS-1701	DAS-1801	DAS-1701	DAS-1801
1	0 to +5V	$\pm 5V$	160 kS/s	333 kS/s	150 kS/s	312.5 kS/s
5	0 to +1V	$\pm 1V$	160 kS/s	333 kS/s	150 kS/s	312.5 kS/s
50	0 to +100mV	$\pm 100mV$	160 kS/s	333 kS/s	150 kS/s	312.5 kS/s
250	0 to +20mV	$\pm 20mV$	36 kS/s	75 kS/s	36 kS/s	75 kS/s

## DAS-1702/1802AO, DAS-1802HC, DAS-1702/1802ST

Gain	Unipolar	Bipolar	Single Channel Throughput*		Aggregate Throughput*	
			DAS-1702	DAS-1802	DAS-1702	DAS-1802
1	0 to +10V	$\pm 10V$	160 kS/s	333 kS/s	150 kS/s	312.5 kS/s
2	0 to +5V	$\pm 5V$	160 kS/s	333 kS/s	150 kS/s	312.5 kS/s
4	0 to +2.5V	$\pm 2.5V$	160 kS/s	333 kS/s	150 kS/s	312.5 kS/s
8	0 to +1.25V	$\pm 1.25V$	160 kS/s	333 kS/s	150 kS/s	312.5 kS/s

## DAS-1702/1802HR

Gain	Unipolar	Bipolar	Single Channel Throughput*		Aggregate Throughput*	
			DAS-1702HR	DAS-1802HR	DAS-1702HR	DAS-1802HR
1	0 to +10V	$\pm 10V$	46 kS/s	98 kS/s	50 kS/s	100 kS/s
2	0 to +5V	$\pm 5V$	46 kS/s	98 kS/s	50 kS/s	100 kS/s
4	0 to +2.5V	$\pm 2.5V$	46 kS/s	98 kS/s	50 kS/s	100 kS/s
8	0 to +1.25V	$\pm 1.25V$	46 kS/s	98 kS/s	50 kS/s	100 kS/s

\* Divide sampling rate by number of channels scanned to arrive at throughput per channel.

A 256-location channel-gain queue on the DAS-1700/1800AO, DAS-1700/1800HR, and DAS-1700/1800ST (64 locations on the DAS-1800HC) allows high speed acquisition with channels at different gains and in non-sequential order using DMA or interrupt-based data transfer modes. The onboard 1024-location FIFO ensures that high speed acquisition can be maintained reliably under both DOS and Windows. The DAS-1700/1800 Series supports single-channel 16-bit DMA, dual-channel 16-bit DMA, interrupt, or programmed I/O data transfer modes.

The DAS-1700/1800 Series features flexible clocking, triggering, and gating modes. You can configure the DAS-1700/1800 Series boards to accept an external pacer clock input or use the onboard time base to provide a conver-

sion rate from 4.32 samples/hr to 333 ksamples/s (to 160kSamples/s for the DAS-1700).

The programmable burst mode capability allows you to acquire data from a series of channel scans at high speed with a programmed interval between scans. This mode emulates a simultaneous sample-and-hold function.

External hardware trigger and gate inputs allow precise control over when data is acquired. Flexible trigger modes allow you to acquire data in relationship to a specific event. An event that starts or stops acquisition can be internal or an external digital trigger.

You can configure the DAS-1700/1800 Series for several triggering modes, including: post-trigger, pre-trigger, and about-trigger.

- Post-trigger is the standard acquisition mode; acquisition begins after an internal or external trigger event and continues until an end condition occurs or the specified number of samples are collected.
- Pre-trigger mode allows acquisition to occur until an external trigger occurs.
- About-trigger mode allows acquisition to occur both before and after an external trigger.

The DAS-1700/1800AO, DAS-1700/1800HR, and DAS-1700/1800ST have 5 multiplexing lines for real-time channel expansion of up to 256 differential inputs. All external channels run at the same speeds as the 16 on-board inputs, so the per channel rates on large systems are not compromised when addressing more channels. The 256-location channel-gain queue allows different gains on all channels. An additional real-time gain output allows external accessories to change gains under program control and in real time.

## Analog Outputs

The DAS-1700/1800AO has 2 waveform-quality 12-bit analog outputs. These analog outputs include a dedicated counter/timer, a 2048 location FIFO, and de-glitching circuitry on the outputs to minimize feedthrough of glitches from the converter and insure smooth waveforms at the outputs. You can update the analog outputs by DMA, interrupt or programmed I/O; or the outputs can operate independently of the computer through the use of the onboard FIFO. Waveforms in the FIFO are repeated after a user-defined count or through a hardware trigger input. The analog outputs have a maximum throughput of 500 ksamples/s per channel. You can clock the analog outputs by the onboard clock, the A/D clock, or by an external clock. Analog output ranges of  $\pm 10$  Volt or  $\pm 5$  Volt are software programmable.

The DAS-1800HC provides two 12-bit analog outputs with output voltage ranges of  $\pm 10.0$  Volts. The DAS-1700/1800ST-DA includes four 12-bit analog outputs and the DAS-1700/1800HR-DA provides two 16-bit analog outputs. The analog outputs power up at 0 Volts and can be updated simultaneously.



# DAS-1700/1800 Series

## Digital Inputs and Outputs

The DAS-1800HC has 8 digital outputs and the DAS-1700/1800AO, DAS-1700/1800HR, and DAS-1700/1800ST have 4 digital outputs. A strobe signal is provided for latching the digital output signals into external circuitry. All boards in the series have 4 digital inputs. +5V, -15V, and +15V are available at the connector for supplying power to external accessories or circuitry.

The DAS-1800HC has a 100-pin connector and the DAS-1700/1800AO, DAS-1700/1800HR, and DAS-1700/1800ST have 50-pin connectors at the rear of the PC for making connections. Accessories are available for direct screw terminal connection, connection to modular signal conditioning, expansion and simultaneous sample-and-hold.

## Software

The array of free software included with Keithley's data acquisition products helps developers get applications "Up and Running" quickly. For example, a new start-up software utility makes it possible to interact with a new board in a matter of minutes. Software drivers are provided on a CD for fast, uncomplicated installation. These 32-bit DriverLINX device drivers for Visual Basic, C/C++, and Delphi also help speed defining new applications by offering both DLL and ActiveX interfaces. A variety of useful examples and on-line help are provided with Keithley's software. Of course, Keithley's easy-to-use application development package, TestPoint, takes advantage of the DriverLINX feature set.

Each board comes bundled with a free set of Keithley's new LabVIEW VIs. Designed with the same "form and feel" as National's VIs, there is no need to learn new commands or techniques to use Keithley's VIs successfully right out of the box.

- FREE new bundled start-up software
- FREE ExceLINX—Excel Add-In (no programming required)
- FREE VisualSCOPE (no programming required)
- DriverLINX 32-bit Device Drivers—Visual Basic, C/C++, Delphi, TestPoint, LabVIEW, DLL, and ActiveX
- FREE new bundled LabVIEW VIs
- Runs under Windows 95/98/NT/2000

## ANALOG INPUTS (DAS-1700AO/ST AND DAS-1800AO/HC/ST)

### NUMBER OF CHANNELS:

8 differential or 16 single-ended; software-configurable with software selectable remote sense (DAS-1700/1800AO/ST).

32 differential or 64 single-ended; software-configurable (DAS-1800HC).

A/D FIFO BUFFER SIZE: 1024 words.

### CHANNEL/GAIN QUEUE LENGTH:

256 locations (DAS-1700/1800AO/ST); 64 locations (DAS-1800HC).

RESOLUTION: 12 bits.

### INPUT GAINS:

DAS-1701AO/ST, DAS-1801AO/HC/ST: 1, 5, 50, 250.

DAS-1702AO/ST, DAS-1802AO/HC/ST: 1, 2, 4, 8.

INPUT RANGES:	BIPOLAR	UNIPOLAR
DAS-1701/AO/ST	±5V, ±1V, ±100mV	0 - 5V, 0 - 1V
DAS-1801AO/HC/ST	±20mV	0 - 100mV, 0 - 20mV
DAS-1702/AO/ST	±10V, ±5V, ±2.5V	0 - 10V, 0 - 5V
DAS-1802AO/HC/ST	±1.25V	0 - 2.5V, 0 - 1.25V

INPUT RANGE SELECTION: Software programmable.

### INPUT OVERVOLTAGE:

±15V continuous, powered; ±15V continuous, unpowered.

### INPUT BIAS CURRENT:

±40nA max. @ 25°C; ±60nA max. over operating temperature.

INPUT IMPEDANCE: >100MΩ in parallel with 90pF.

THROUGHPUT—SINGLE CHANNEL: 333kS/s for DAS-1800 and 160kS/s for DAS-1700, for any gain or range.

### THROUGHPUT—DAS-1701/AO/ST, DAS-1801AO/HC/ST

(multiple channels, at the same gain):

GAIN	BIPOLAR INPUTS		UNIPOLAR INPUTS	
	DAS-1700	DAS-1800	DAS-1700	DAS-1800
1	160 kS/s	312.5 kS/s	160 kS/s	312.5 kS/s
5	160 kS/s	312.5 kS/s	160 kS/s	312.5 kS/s
50	160 kS/s	312.5 kS/s	96 kS/s	200 kS/s
250	36 kS/s	75 kS/s	39 kS/s	60 kS/s

### THROUGHPUT—DAS-1700/AO/ST, DAS-1802AO/HC/ST

(multiple channels, at the same gain): 150kS/s for the DAS-1700 and 312.5kS/s for the DAS-1800 for all ranges.

LINEARITY: **Integral:** ±½ LSB typical, ±1 LSB max.

**Differential:** ±1 LSB.

### ABSOLUTE ACCURACY:

±0.01% of reading ±1 LSB for all ranges, typical.

±0.02% of reading ±1 LSB for gain < 250, max. @ 25°C.

±0.03% of reading ±1 LSB for gain = 250, max. @ 25°C.

### TEMPERATURE COEFFICIENTS:

**Offset - unipolar:** ±10μV/°C ± (14μV/°C ÷ gain) max.

**Offset - bipolar:** ±10μV/°C ± (12μV/°C ÷ gain) max.

**GAIN: Gain < 50:** ±20ppm/°C of FS max.

**Gain = 50:** ±30ppm/°C of FS max.

**Gain = 250:** ±35ppm/°C of FS max.

CONVERSION TIME: 3.0μs max.

### NOISE (DAS-1701AO, DAS-1801AO/HC/ST):

Gain	Bipolar (counts)	Unipolar (counts)
1	p-p = 1; rms = 0.1	p-p = 1; rms = 0.1
5	p-p = 1; rms = 0.1	p-p = 1; rms = 0.1
50	p-p = 4; rms = 0.5	p-p = 6; rms = 0.9
250	p-p = 8; rms = 1.0	p-p = 9; rms = 1.4

NOISE (DAS-1702AO/ST, DAS-1802AO/HC/ST): p-p = 1; rms = 0.1, for all gains and ranges.

COMMON MODE REJECTION RATIO: **Gain = 1:** 74dB.

**Gain = 2, 4, 5:** 80dB.

**Gain = 8:** 86dB.

**Gain = 1 50, 250:** 100dB.

DATA TRANSFER MODES: DMA (single or dual channel), interrupt, or programmed I/O.



# DAS-1700/1800 Series

## ANALOG INPUTS (DAS-1700/1800HR)

**NUMBER OF CHANNELS:** 8 differential or 16 single-ended; software-configurable with software selectable remote sense.

**A/D FIFO BUFFER SIZE:** 1024 locations.

**CHANNEL/GAIN QUEUE LENGTH:** 256 locations.

**RESOLUTION:** 16 bits.

**INPUT GAINS:** 1, 2, 4, 8.

**INPUT RANGES:**

**Bipolar:**  $\pm 10V$ ,  $\pm 5V$ ,  $\pm 2.5V$ ,  $\pm 1.25V$ .

**Unipolar:** 0 to +10V, 0 to +5V, 0 to +2.5V, 0 to +1.25V.

**INPUT RANGE SELECTION:** Software programmable.

**INPUT OVERVOLTAGE:**  $\pm 15V$  continuous, powered;  $\pm 15V$  continuous, unpowered.

**INPUT BIAS CURRENT:**  $\pm 40nA$  max. @ 25°C;  $\pm 60nA$  max. over operating temperature.

**INPUT IMPEDANCE:**  $>100M\Omega$  in parallel with 90pF.

**THROUGHPUT, SINGLE CHANNEL:** 48kS/s for the DAS-1700 and 100kS/s for the DAS-1800, for any gain or range.

**THROUGHPUT, MULTIPLE CHANNELS:** 47kS/s for the DAS-1700 and 98kS/s for the DAS-1800, at the same gain, all ranges.

**THROUGHPUT, MULTIPLE CHANNELS:** 29kS/s for the DAS-1700 and 60kS/s for the DAS-1800, with gain change.

**LINEARITY DIFFERENTIAL:**  $\pm 1LSB$ . Monotonicity guaranteed over operating range.

**ABSOLUTE ACCURACY:**

**Typical, all ranges:**  $\pm 0.005\%$  of reading  $\pm 1LSB$ .

**Maximum for gain = 1:**  $\pm 0.005\%$  of reading  $\pm 1.5LSB$ .

**Maximum for gain > 1:**  $\pm 0.001\%$  of reading  $\pm 1.5LSB$ .

**RELATIVE ACCURACY:**

**Typical:**  $\pm 0.001\%$  of reading  $\pm 1LSB$ .

**Maximum for 0–70°C:**  $\pm 0.001\%$  of reading  $\pm 1.5LSB$ .

**TEMPERATURE COEFFICIENTS:**

**Offset:**  $\pm 5\mu V/^\circ C$  max.

**Gain:**  $\pm 7.5ppm/^\circ C$  of FS max.

**Conversion time:** 8 $\mu s$  max.

**NOISE:**

Gain	Bipolar (counts)	Unipolar (counts)
1	p-p = $\pm 2$ ; rms = 0.5	p-p = $\pm 2$ ; rms = 0.6
2	p-p = $\pm 2$ ; rms = 0.5	p-p = $\pm 2$ ; rms = 0.6
4	p-p = $\pm 2.5$ ; rms = 0.6	p-p = $\pm 2.5$ ; rms = 0.7
8	p-p = $\pm 2.5$ ; rms = 0.7	p-p = $\pm 3$ ; rms = 0.8

**COMMON MODE REJECTION RATIO:** Gain = 1: 74dB.  
Gain = 2, 4: 80dB.  
Gain = 8: 86dB.

**DATA TRANSFER MODES:** DMA (single or dual channel), interrupt, or programmed I/O.

## ANALOG OUTPUTS (DAS-1700/1800AO ONLY)

**NUMBER OF CHANNELS:** 2.

**RESOLUTION:** 12 bits.

**RANGE:**  $\pm 5V$ ,  $\pm 10V$ , software programmable.

**FIFO:** 2048 words.

**OUTPUT DRIVE CURRENT:**  $\pm 15mA$  max.

**CAPACITIVE LOAD DRIVE:** 100 $\mu F$  max.

**GAIN ACCURACY:** Adjustable to zero.

**OFFSET ACCURACY:** Adjustable to zero.

**LINEARITY:** **Integral:**  $\pm 0.25LSB$  typical,  $\pm 0.75LSB$  max.  
**Differential:**  $\pm 0.75LSB$  max.

**POWER-UP STATE:** 0.0V.

**SAMPLE CLOCK:** Internal clock, 7S/s to 500kS/s, A/D clock or external clock.

**SETTLING TIME:** 3 $\mu s$  for 20V step, typical; 1.8 $\mu s$  for LSB of major carry, typical.

**THROUGHPUT:** 500kS/s max. for the DAS-1700 and 500kS/s max., per channel in recycle mode.

**GLITCH ENERGY:** Zero glitch feedthrough.

**TRIGGER SOURCES:** Internal, external trigger, or external gate.

**DATA TRANSFER MODES:** DMA, interrupt, or programmed I/O.

## ANALOG OUTPUTS (DAS-1800HC ONLY)

**NUMBER OF CHANNELS:** 2.

**RESOLUTION:** 12 bits.

**RANGE:**  $\pm 10V$ .

**ABSOLUTE ACCURACY:**  $\pm 1LSB$  max.

**OUTPUT DRIVE CURRENT:**  $\pm 5mA$  max.

**CAPACITIVE LOAD DRIVE:** 100 $\mu F$ .

**LINEARITY:** **Integral:**  $\pm \frac{1}{4}LSB$  typ.;  $\pm \frac{1}{2}LSB$  max.

**POWER-UP STATE:** 0.0V.

**GLITCH ENERGY:** 300nV-seconds.

**DATA TRANSFER MODES:** Interrupt or programmed I/O.

## DIGITAL I/O (ALL DAS-1700/1800 SERIES)

**INPUT BITS:** 4.

**INPUT LOW:**  $V_{IL}$  = 0.8V max.;  $I_{IL}$  =  $-0.2mA$  max.

**INPUT HIGH:**  $V_{IH}$  = 2.0V min.;  $I_{IH}$  = 20 $\mu A$  max.

**OUTPUT BITS:** DAS-1800HC: 8.

DAS-1700/1800AO/HR/ST: 4.

**OUTPUT LOW:**  $V_{OL}$  = 0.5V max. @  $I_{OL}$  = 8mA.

**OUTPUT HIGH:**  $V_{OH}$  = 2.7V min. @  $I_{OH}$  =  $-400\mu A$ .

**DIGITAL OUTPUT STROBE PULSE WIDTH:** 300ns typ.; data is latched on rising edge.

**DATA TRANSFER MODES:** Interrupt or programmed I/O.

## CLOCK/TIMER (ALL DAS-1700/1800 SERIES)

**MAXIMUM PACER CLOCK RATE:** 160kHz/50kHz for DAS-1700HR and 333kHz/100kHz for DAS-1800HR.

**MINIMUM PACER CLOCK RATE:** 0.0012Hz.

**EXTERNAL PACER CLOCK RATE:** 160kHz/50kHz for DAS-1700HR and 333kHz max/100kHz for DAS-1800HR.

**EXTERNAL PACER CLOCK PULSE WIDTH:** 10ns min.

**HARDWARE TRIGGER PULSE WIDTH:** 10ns min.

## MISCELLANEOUS

**DMA LEVELS:** 5, 6, 7 – software configurable for 1 or 2 channels (up to 3 for DAS-1800AO).

**INTERRUPT LEVELS:** 3, 5, 7, 10, 11, 15 – software configurable.

**MAX. CURRENT AT  $\pm 15V$  OUTPUTS:** 30mA.

**MAX. CURRENT AT +5V OUTPUT:** 1.0A.

## DAS-1700/1800AO POWER REQUIREMENTS

**+5V:** 510mA typ., 835mA max.

**+12V:** 455mA typ., 690mA max.

## DAS-1800HC POWER REQUIREMENTS

**+5V:** 430mA typ., 870mA max.

**+12V:** 400mA typ., 550mA max.

## DAS-1700/1800HR POWER REQUIREMENTS

**+5V:** 500mA typ., 870mA max.

**+12V:** 200mA typ., 550mA max.

## DAS-1700/1800ST POWER REQUIREMENTS

**+5V:** 430mA typ., 870mA max.

**+12V:** 400mA typ., 550mA max.

## ENVIRONMENTAL

**OPERATING TEMPERATURE:**  $^\circ C$  to  $+50^\circ C$

**STORAGE TEMPERATURE:**  $-20^\circ C$  to  $+70^\circ C$

**HUMIDITY:** 0 to 95% (non-condensing)

**EMC:** Conforms to European Union Directive 89/336/EEC.

**SAFETY:** Meets EN61010-1/IEC 1010.

**DIMENSIONS:** 13.3in L  $\times$  4.25in H  $\times$  0.75in D (33.8cm  $\times$  10.8cm  $\times$  1.9cm).

# DAS-1700/1800 Series

## Connector Pin Assignments

The analog input, analog output, and digital input and output connections of the DAS-1700/1800AO, DAS-1700/1800HR, and DAS-1700/1800ST are made with a 50-pin D-type connector at the rear of the computer. The analog input, analog output, and digital input and output connections of the DAS-1800HC are made with a 100-pin D-type connector at the rear of the computer.

	BankA Pin	BankB Pin	
AGND	1	1	AGND
CH16 HI	2	2	CH00 HI
CH16 LO / CH48 HI	3	3	CH00 LO / CH32 HI
CH17 HI	4	4	CH01 HI
CH17 LO / CH49 HI	5	5	CH01 LO / CH33 HI
CH18 HI	6	6	CH02 HI
CH18 LO / CH50 HI	7	7	CH02 LO / CH34 HI
CH19 HI	8	8	CH03 HI
CH19 LO / CH51 HI	9	9	CH03 LO / CH35 HI
CH20 HI	10	10	CH04 HI
CH20 LO / CH52 HI	11	11	CH04 LO / CH36 HI
CH21 HI	12	12	CH05 HI
CH21 LO / CH53 HI	13	13	CH05 LO / CH37 HI
CH22 HI	14	14	CH06 HI
CH22 LO / CH54 HI	15	15	CH06 LO / CH38 HI
CH23 HI	16	16	CH07 HI
CH23 LO / CH55 HI	17	17	CH07 LO / CH39 HI
AGND	18	18	AGND
CH24 HI	19	19	CH08 HI
CH24 LO / CH56 HI	20	20	CH08 LO / CH40 HI
CH25 HI	21	21	CH09 HI
CH25 LO / CH57 HI	22	22	CH09 LO / CH41 HI
CH26 HI	23	23	CH10 HI
CH26 LO / CH58 HI	24	24	CH10 LO / CH42 HI
CH27 HI	25	25	CH11 HI
CH27 LO / CH59 HI	26	26	CH11 LO / CH43 HI
CH28 HI	27	27	CH12 HI
CH28 LO / CH60 HI	28	28	CH12 LO / CH44 HI
CH29 HI	29	29	CH13 HI
CH29 LO / CH61 HI	30	30	CH13 LO / CH45 HI
CH30 HI	31	31	CH14 HI
CH30 LO / CH62 HI	32	32	CH14 LO / CH46 HI
CH31 HI	33	33	CH15 HI
CH31 LO / CH63 HI	34	34	CH15 LO / CH47 HI
H31 LO / CH65 HI	34	34	AGND
AGND	35	35	AGND
DAC1 OUT	36	36	DAC0 OUT
-15 V	37	37	+15 V
DGND	38	38	DGND
NC	39	39	D10 / XPCLK
SSHO	40	40	D11 / TGIN
TGOUT	41	41	D12
DOSTB	42	42	D13
DO4	43	43	DO0
DO5	44	44	DO1
DO6	45	45	DO2
DO7	46	46	DO3
+5 V	47	47	+5 V
+5 V	48	48	+5 V
DGND	49	49	DGND
DGND	50	50	DGND

DAS-1700/1800HC

	Pin	Pin	
(User CommonMode)U_CMMD	1	26	CH00 HI
CH00LOor CH08HI	2	27	CH01 HI
CH01LOor CH09HI	3	28	CH02 HI
CH02LOor CH10HI	4	29	CH03 HI
CH03LOor CH11HI	5	30	CH04 HI
CH04LOor CH12HI	6	31	CH05 HI
CH05LOor CH13HI	7	32	CH06 HI
CH06LOor CH14HI	8	33	CH07 HI
CH07LOor CH15HI	9	34	LLGND
(DAS-1700/1800ST-DA) 0DAC 2	10	35	0DAC 0 (DAS-1700/1800AO/HR-DA/ST-DA)
(DAS-1700/1800ST-DA) 0DAC 3	11	36	0DAC 1 (DAS-1700/1800AO/HR-DA/ST-DA)
+15V	12	37	-15V
LLGND	13	38	LLGND
DGND	14	39	GEXT
D11	15	40	D10
D13	16	41	D12
DO1	17	42	DO0
DO3	18	43	DO2
DOSTB	19	44	XPCLK
TGOUT	20	45	SSHO
MUX03	21	46	TGIN
MUX05	22	47	MUX04
MUX07	23	48	MUX06
+5V	24	49	+5V
DGND	25	50	DGND

DAS-1700/1800HR/ST

## Configuration Guide

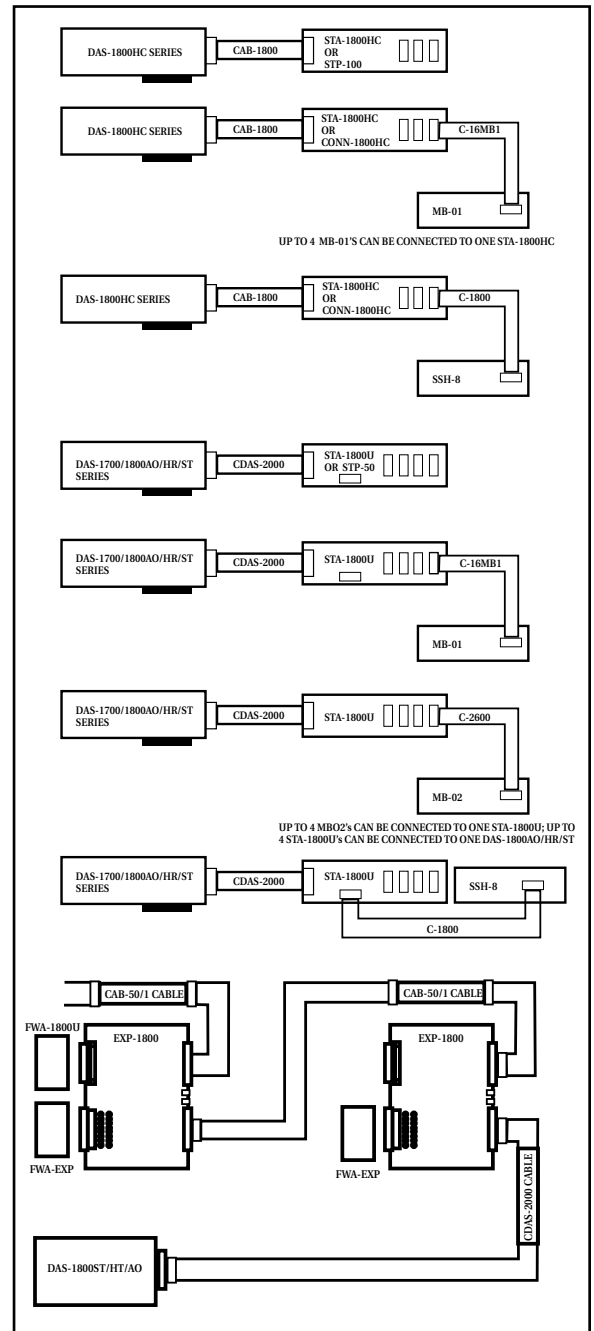

### QUESTIONS?

1-800-552-1115 (U.S. only)

Call toll free for technical assistance, product support or ordering information, or visit our website at [www.keithley.com](http://www.keithley.com).

# DAS-1700/1800 Series

ORDER	DESCRIPTION	OPTIONS
<b>HARDWARE</b>		
DAS-1701AO	160 kS/s Analog and Digital I/O Board with gains of 1, 5, 50, 250 and two waveform quality analog outputs	<b>C-16MB1</b> MB01 backplane to STA-1800HC or STA-1800U cable
DAS-1702AO	160 kS/s Analog and Digital I/O Board with gains of 1, 2, 4, 8 and two waveform quality analog outputs	<b>CAB-1800</b> DAS-1800HC to STA-1800HC 100-pin, 18-inch cable
DAS-1702HR	High Resolution 50 kS/s Analog and Digital I/O Board with gains of 1, 2, 4, and 8	<b>CAB-1801</b> DAS-1800HC to STA-1800HC 100-pin, 36-inch cable
DAS-1702HR-DA	High Resolution 50 kS/s Analog and Digital I/O Board with gains of 1, 2, 4, and 8 and two analog outputs	<b>CAB-1802</b> DAS-1800HC to STA-1800HC 100-pin, 72-inch cable
DAS-1701ST	Standard 160 kS/s Analog and Digital I/O Board with gains of 1, 5, 50, 250	<b>CAB-1800/S</b> DAS-1800HC to STA-1800HC 100-pin, 18-inch shielded cable
DAS-1701ST-DA	Standard 160 kS/s Analog and Digital I/O Board with gains of 1, 5, 50, 250 and four analog outputs	<b>CAB-1801/S</b> DAS-1800HC to STA-1800HC 100-pin, 36-inch shielded cable
DAS-1702ST	Standard 160 kS/s Analog and Digital I/O Board with gains of 1, 2, 4, 8	<b>CAB-1802/S</b> DAS-1800HC to STA-1800HC 100-pin, 72-inch shielded cable
DAS-1702ST-DA	Standard 160 kS/s Analog and Digital I/O Board with gains of 1, 2, 4, 8 and 4 analog outputs	<b>CDAS-2000</b> DAS-1700/1800AO, DAS-1700/1800HR or DAS-1700/1800ST to STA-1800U cable
DAS-1801AO	333 kS/s Analog and Digital I/O Board with gains of 1, 5, 50, 250 and two waveform quality analog outputs	<b>CONN-1800HC</b> Connector Accessory for the DAS-1800HC
DAS-1802AO	333 kS/s Analog and Digital I/O Board with gains of 1, 2, 4, 8 and two waveform quality analog outputs	<b>EXP-1800</b> Signal Conditioning and Expansion Accessory Board
DAS-1801HC	High Channel Count 333 kS/s Analog and Digital I/O Board with gains of 1, 5, 50, 250	<b>MB-Series</b> Modular, Isolated, Plug-In Signal Conditioners
DAS-1802HC	High Channel Count 333 kS/s Analog and Digital I/O Board with gains of 1, 2, 4, 8	<b>MS-DAS-1700</b> Upgrade to latest version of DriverLINX software and hardware manuals for DAS-170x.
DAS-1802HR	High Resolution 100 kS/s Analog and Digital I/O Board with gains of 1, 2, 4, and 8	<b>MS-DAS-1800ST/HR</b> Upgrade to latest version of DriverLINX software and hardware manuals for DAS-180xST/HR.
DAS-1802HR-DA	High Resolution 100 kS/s Analog and Digital I/O Board with gains of 1, 2, 4, and 8 and two analog outputs	<b>MS-DAS-1800HC</b> Upgrade to latest version of DriverLINX software and hardware manuals for DAS-1801HC/1802HC.
DAS-1801ST	Standard 333 kS/s Analog and Digital I/O Board with gains of 1, 5, 50, 250	<b>MS-DAS-1800AO</b> Upgrade to latest version of DriverLINX software and hardware manuals for DAS-1801AO/1802AO.
DAS-1801ST-DA	Standard 333 kS/s Analog and Digital I/O Board with gains of 1, 5, 50, 250 and four analog outputs	<b>SDAS-2000</b> DAS-1700/1800AO, DAS-1700/1800HR or DAS-1700/1800ST to STA-1800U shielded cable
DAS-1802ST	Standard 333 kS/s Analog and Digital I/O Board with gains of 1, 2, 4, 8	<b>SSH-8</b> 8-Channel, Simultaneous Sample-and-Hold Accessory Board (compatible with DAS-1700 Series only)
DAS-1802ST-DA	Standard 333 kS/s Analog and Digital I/O Board with gains of 1, 2, 4, 8 and 4 analog outputs	<b>STA-1800HC</b> Screw Terminal Accessory for the DAS-1800HC Series
<b>INCLUDED SOFTWARE</b>		<b>STA-1800U</b> Universal Screw Terminal Accessory for the DAS-1700/1800AO, DAS-1700/1800HR and DAS-1700/1800ST
FREE bundled NEW Start-Up Software		<b>STP-100</b> Screw Terminal Panel for 100-pin connectors
FREE ExcelLINX—Excel Add-In		<b>STP-50</b> Screw Terminal Panel for 50-pin connectors
FREE VisualSCOPE		<b>TESTPOINT</b> TestPoint Software Package
FREE bundled NEW LabVIEW VIs		
DriverLINX 32-bit Device Drivers—DLL and ActiveX		
Supports Visual Basic, C/C++, Delphi, TestPoint, and LabVIEW		
Runs under Windows 95/98/ NT/2000		
		See page 479 for descriptions of all accessories.



## QUESTIONS?

1-800-552-1115 (U.S. only)

Call toll free for technical assistance, product support or ordering information, or visit our website at [www.keithley.com](http://www.keithley.com).