

Ensuring Reliable Delivery of Triple Play Bundled Services Over FTTx

Success depends on using an application-aware test and service assurance strategy

The pressure is on TELCO Service Providers. As competition increases, they need to act fast before competitors' service offerings significantly impact their profits. Bundled services of voice, data, and video are the solutions that they are choosing in their quest to retain both customers and profits.

Cable MSOs are offering voice and data to their subscribers on top of broadcast video, and they are rolling out new video-on-demand services. Wireless carriers are taking voice business away from traditional voice providers, and they are offering new wireless broadband data services, including video, to their own subscribers. The more new services competitors offer, the more important it becomes for TELCOs to ensure that their services meet the high expectations of customers, both new and existing.

To survive, TELCOs are beefing up their broadband networks with fiber as they add video to their voice and data offerings. Service Providers are making FTTx networks an essential part of their competitive strategies to offer Triple Play services – IP-based voice, data, and video. Fortunately, the technologies used to build FTTx networks, including passive optical networks, digital subscriber line (DSL), and new video compression techniques are approaching practical price points. FTTx networks are playing an increasingly important role in helping Service Providers stay in the game, retain existing customers, and ultimately, win new ones.

As if the demands of deploying FTTx networks are not difficult enough, Service Providers must also ensure that the Triple Play services they deliver perform flawlessly. If Service Providers successfully deploy FTTx physical plants, but the services they deliver are sub-par, they face the possibility of forever losing once loyal customers to competitors that are

offering the same type of service packages with better quality. Customers become more and more unforgiving as competition increases, and there are no signs of competition slowing any time soon.

To accomplish their goals of building FTTx networks that deliver high-quality, IP-based Triple Play applications, TELCOs must add an application-aware test and service assurance strategy to their arsenal of test processes and procedures. New test and measurement equipment as well as service assurance systems with highly integrated capabilities and multi-port access are necessities. These solutions must enable field technicians and operational support personnel to test the quality of service (QoS) of each IP-based application and test the network at the physical layer. Both the network's physical transport mechanisms and packet flow mechanisms must meet stringent parameters in order to deliver proper application-specific QoS levels.

Building Blocks of Triple Play

Triple Play services can be delivered via multiple access technologies that fall under the FTTx umbrella. FTTx actually represents a set of new network architectures designed to deliver broadband services to the customer premises. Fiber may or may not extend all the way to the premises as it does in FTTP (P for premises) architectures. An xDSL technology, such as ADSL2+, may be used in the last mile from the fiber node to the customer premises equipment (CPE) (see Figure 1).

It is important to note that even in FTTP, there is a critical in-house wiring or connection system component. The Service Provider may run Category 5 wire to a home router, PC, or set top box. Wireless technology may be used as an in-house network, but Home PNA (twisted pair LAN technology) or Home Plug (PLT-AC Power Line LAN technology)

may also be used. Even coaxial cable may be used for in-house data and video connections. In fact, in most FTTx networks, it is a safe bet that fiber, copper, coax, wireless, or some combination of all of these will carry the signals bearing Triple Play applications to integrated home networking devices, TV sets, and adapters for VoIP and voice applications.

When deploying Triple Play services over FTTx, testing of all physical media utilized, especially the copper access loop, becomes more important than ever before. While Service Providers could get away with testing copper, focusing only on narrowband voice in the past, such practices will not work well in FTTx networks. Because xDSL demands so much more of the copper plant, a thorough test suite for narrowband **and** broadband transmission over copper is now necessary to ensure proper performance of the physical medium.

FTTx networks are being deployed quickly, because time is of the essence as competition continues to heat up. However, it is unwise to cut corners when it comes to testing FTTx networks and making sure that they are performing properly. As this paper will explain, successful delivery of IP-based Triple Play services over FTTx infrastructures will require Service Providers to do much more than deploy physical infrastructure and remotely check to see if packets are being transported across the network.

Multi-layer testing of the network and the applications it delivers must take place during the entire lifecycle of the network—installation, provisioning, and service assurance phases. To test the physical plant as well as applications over this lifecycle, multiple testing methods and types of equipment are needed at various points in the network.

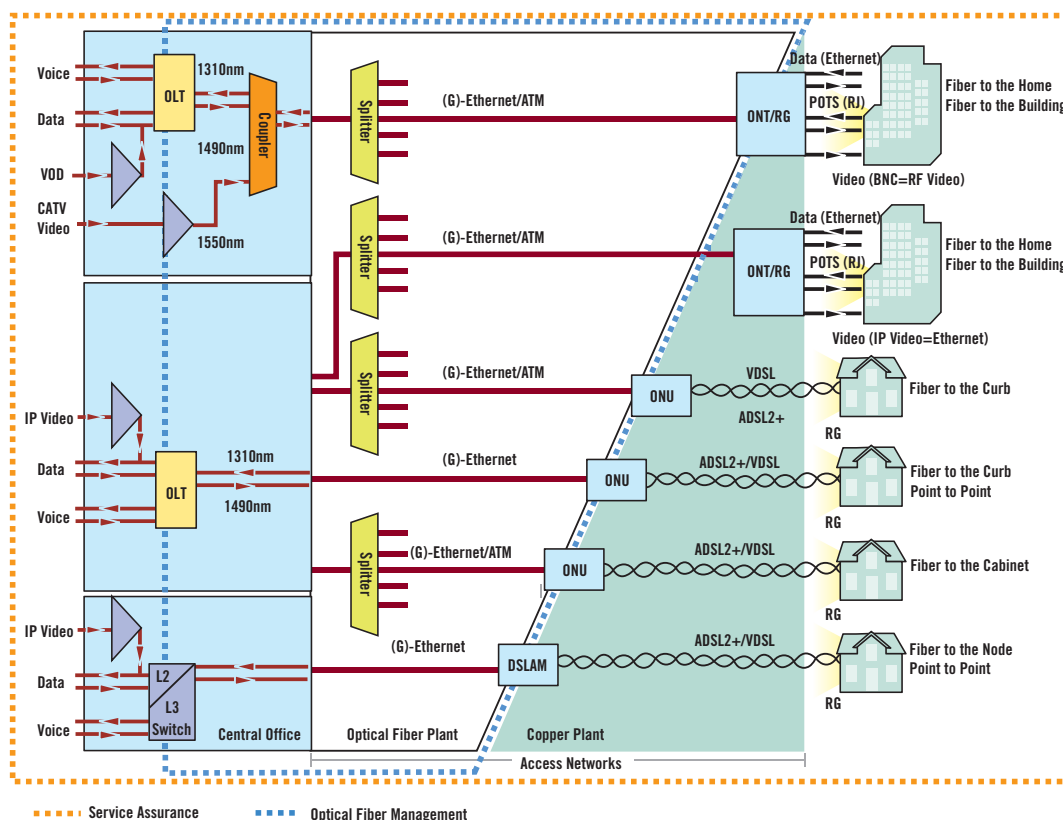

Figure 1 - FTTx Architectures

During the installation phase, fiber plant characterization is accomplished and insertion loss and optical return loss measurements are obtained. In the provisioning phase, optical power measurements are obtained, xDSL data performance is measured, and voice, video and data performance is verified. After the network is deployed and services are in use, service assurance testing becomes the norm. Field technicians must be able to efficiently isolate faults, perform end-to-end service verification, and support an efficient trouble resolution process.

Testing Triple Play Services

As with the physical plant, turning up Triple Play services is performed in three different stages—network element installation and pre-qualification, premises provisioning, and service assurance and maintenance (see Figure 2).

Each lifecycle stage brings different challenges to each of the three Triple Play services.

IP Video

Before IP video service can be turned up, Service Providers must determine the suitability of the customer’s access network for IP video. Video Class of Service (CoS) mechanisms, such as VLAN tag segregation, load planning, and resulting bandwidth, must be determined. DSLAM equipment must be upgraded to support Internet Group Management Protocol (IGMP) snooping and IP multicast functionality. Last mile access topology must be established to support IP video required bandwidths. Typically, the delivery of three simultaneous broadcast video channels is required.

Once these items have been addressed, necessary network elements and connectivity can be provisioned. Network elements that need to be installed and tested include DSL Access Multiplexer (DSLAM) ports, Residential Gateways, in-home wiring, and set top boxes (STBs). Re-qualification of access links may also be completed.

When turning up and provisioning IP video service, provisioning errors and video quality issues are identified. Case-by-base troubleshooting must be performed before service installation can be completed. Ideally, test records in this phase of the process should be captured to provide a baseline reference for future service assurance activities. Such recorded data will improve mean-time-to-repair (MTTR) and result in a much better customer experience, ultimately reducing customer churn.

To improve the installation process, field technicians and their test equipment need to be able to verify three parameters before IP video service can be turned up to a customer-adequate xDSL performance, video service provisioning, and video QoS. Equipment must be able to emulate the customer’s STB, obtain video program flows, and validate the video QoS metrics established by the Service Provider for each parameter.

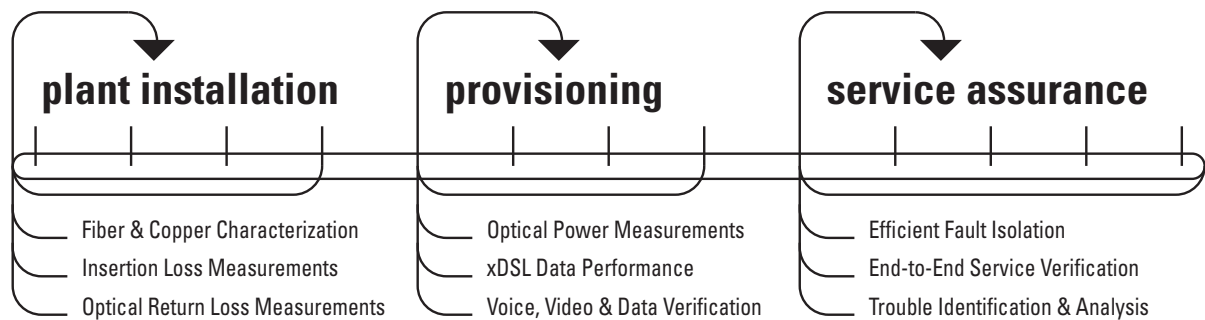

Figure 2 - Lifecycle Stages

Video QoS testing results that are shown on the field technician’s testing devices should show all of the critical parameters that affect video flows. For example, if the program clock reference (PCR) jitter is high, the decoder cannot properly decode the video payload. Trouble with IGMP latency impacts the time it takes to change broadcast video channels and, therefore, is an important “customer experience” component. The number of lost packets in the video transport stream, as measured by the continuity error indicator, is the most critical of the three. Pass/fail thresholds should be set in testing devices for each of these parameters, promoting consistency in operational practices and helping improve service assurance processes for IP video services.

To successfully troubleshoot IP video problems, field technicians and their testing equipment will be looking for IP fault conditions such as video pixelizations or picture freezes. Both problems result from lost packets, excessive packet jitter, or both conditions. If no errors are detected at the physical layer of the access link under test, then it is likely that packet loss is taking place upstream of the DSLAM. PCR jitter will typically be specific to a channel, indicating a problem at the headend, with Local Ad Insertions, or with source material transcoding operations.

Packet loss impacts vary. For instance, loss of a single packet carrying a B-frame in an MPEG-2 video signal affects only one or two frames of the video flow. Loss of a single packet carrying an I-frame affects all frames until the next I-frame. Typically 14 to 15 frames are impacted depending upon the Group Of Picture (GOP) size setting.

Ongoing monitoring of packet flow is required to keep IP video applications running at the QoS levels that customers have come to expect from competitive video Service Providers. Their quality of experience must be better than, or at the very least, equal to their previous experience.

IP Voice

To turn up and provision an enterprise IP voice application, the enterprise network’s suitability for VoIP’s delay-sensitive traffic must be determined. Class-of-Service features must exist in routers, and networks must be revised or re-engineered to accommodate additional voice traffic. Load planning may impact network equipment, especially WAN interface bandwidth requirements. New Service Level Agreements (SLAs) may be required.

In the installation phase, integrated access devices (IADs), voice gateways, routers, and phones are installed and tested. Physical layer testing of the WAN links is performed. Necessary connectivity and network elements can then be provisioned, and new cabling may be installed to the new end points (IP phones or terminal adapters).

As service is turned up, technicians focus on VoIP QoS testing and actual placement of IP phones. Provisioning errors and voice quality issues are identified and resolved before service provisioning can be completed. As with the IP video scenario, test records gathered during this phase of the process should be captured and recorded for future use. Should service problems occur, these records will shorten the trouble resolution process.

When turning up IP voice service, field technicians need to verify connectivity to signaling gateways, service provisioning, and call quality. They also must verify call quality by placing both on-network and off-network (to PSTN) test calls. Critical test call parameters include packet delay, packet loss, and jitter. However, the Mean Opinion Score (MOS) will be the most critical SLA metric used to measure overall VoIP quality.

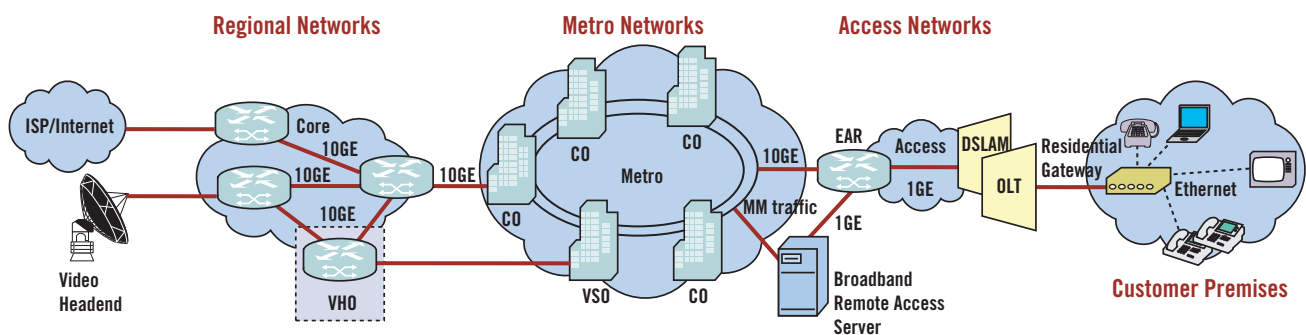

Figure 3 – An IP Video Network

In the service assurance phase, a variety of issues can cause poor VoIP service quality. These issues include CPE-related issues caused by handsets, processor/DSP performance, microphone/earpiece acoustics, and network echo canceller performance. Network hand-offs between the packet network and the TDM network, typically managed by a voice gateway switch, are critical test points in all networks.

IP Internet Data

To provide FTTx subscribers with IP Internet data service, ISP accounts must be established for each customer. Also, traffic planning must be modified to accommodate additional data flow. Broadband remote access servers will be impacted and control/routing and bandwidth planning must be completed. In addition to establishing connectivity to ISPs and provisioning necessary network elements for increased data flow and CoS treatment, DSLAM ports may be reconfigured for dual-latency path support in this mixed application environment.

To complete the installation process, field technicians must verify DSL physical layer performance, ISP connectivity, and data service throughput. This is accomplished using a test tool with Web browser and FTP throughput test capabilities. Using selectable test file sizes and both up-load and down-load testing, FTP throughput tests establish performance of the link that more closely models actual use cases than a simple download test. It is also wise to perform an HTTP test using a Web browser to ensure that the end users' ISP access/connectivity is working properly.

As IP Internet data service is turned up, provisioning accuracy must be validated. Again, records of any troubleshooting or issues should be captured and kept for future reference.

Triple Play Requires Triple Testing

Testing must be performed at multiple layers, including physical layer, data link layer, network layer, and application layer. Simple physical layer testing in the access network does not reveal all of the potential QoS issues that can impact packet-based Triple Play applications.

Clearly, packet transport is affected by end-to-end packet flow. Service Providers deploying FTTx networks need a complete application-aware test and service assurance strategy to follow in order to properly install, provision, and maintain the quality of new IP-based services upon which their survival depends.

As described above, it may seem that these new testing requirements are overwhelming, with endless details that field technicians and their equipment must address in order to deliver high-quality Triple Play services over FTTx networks. However, integrated Triple Play capable test tools simplify the technician's job. Leaving no testing stone unturned will go a long way to ensuring that the Service Providers' significant investments in FTTx networks are not stranded by unhappy customers who migrate to competitors, never to return.

**Worldwide
Headquarters**

One Milestone Center Court
Germantown, Maryland
20876-7100
USA

Acterna is present in more
than 80 countries. To find
your local sales office go to:
www.acterna.com

**Regional Sales
Headquarters**

North America
One Milestone Center Court
Germantown, Maryland
20876-7100
USA
Toll Free: 1 866 ACTERNA
Toll Free: 1 866 228 3762
Tel: +1 301 353 1560x2850
Fax: +1 301 353 9216

Latin America
Acterna do Brasil Ltda.
Av. Eng. Luis Carlos Berrini
936 9th Floor
04571-000 São Paulo
SP-Brazil
Tel: +55 11 5503 3800
Fax: +55 11 5505 1598

Asia Pacific
Acterna Hong Kong Ltd.
Suite 4010, 40th Floor
China Resources Building
26 Harbour Road
Wanchai
Hong Kong
Tel: +852 2892 0990
Fax: +852 2892 0770

**Europe, Middle East &
Africa**
Acterna Germany GmbH
Mühleweg 5
72800 Eningen u.A.
Germany
Tel: +49 7121 86 2222
Fax: +49 7121 86 1222

© Copyright 2004
Acterna, LLC.
All rights reserved.

Acterna, Communications
Test and Management
Solutions, and its logo are
trademarks of Acterna,
LLC. All other trademarks
and registered trademarks
are the property of their
respective owners. Major
Acterna operations sites
are ISO 9001 registered.

Note: Specifications,
terms and conditions
are subject to change
without notice.