

AQ2200 Series

AQ2200-621/622 Optical Modulator
AQ2200-631 Optical Receiver



Optical Modulator and Optical Receiver for 10G BERT Module

- Supports 10G bit/s bandwidth
- Can be combined with a wide range of optical modules

The AQ2200 Series can be combined with LD light sources, optical attenuators, optical power meters, and other optical modules to measure optical characteristics.

Please note the following if you are planning to purchase the AQ2200-621, -622, or -631:

* A separately sold AQ2201 or AQ2202 frame controller is also required.

* See the relevant sections of the AQ2201/AQ2202 catalog for the AQ2201/AQ2202 frame controller specifications.

Optical Modulator

AQ2200-621/AQ2200-622

The AQ2200-621 and -622 are optical modulator modules designed for use with the AQ2200 Series AQ2200-601 BERT module. The PPG electrical signal from the AQ2200-601 BERT module is modulated to Optical signal. The AQ2200-621 and -622 should be used together with the AQ2200-111 optical light source module (PMF option).

- Extinction ratio adjustment function (6 dB to 12 dB)
Be sure to use an oscilloscope to establish the relationship between the setpoint and extinction ratio before using the output light Extinction ratio.
- Cross point adjustment function
- Auto-Bias Control ON/OFF function
- Bias Slope switching function



Optical Receiver

AQ2200-631

The AQ2200-631 is an optical receiver module for the AQ2200 Series AQ2200-601 BERT module. It converts an optical signal to an electric signal which can be input to the ED unit in the AQ2200-601 BERT module.

Note that the AQ2200-631 cannot be used as a waveform monitor because a limiting amp is positioned in the stage subsequent to optical/electrical conversion.

- Data threshold value adjustment function
- Overload detection function
- Loss detection function
- Optical power monitor function (-19 dBm to +3 dBm)
- Data Out ON/OFF function



Specifications

Item	Specification	Remarks
Storage temperature	-10°C to 50°C, 80% relative humidity or less, with no condensation	
Operating temperature	5°C to 40°C, 80% relative humidity or less, with no condensation	
Wavelength range	AQ2200-621: 1530-1570 nm AQ2200-622: 1290-1330 nm	Note 1
Wavelength stability	Depends on specifications of AQ2200-111 DFB-LD module	
Optical power stability	Depends on specifications of AQ2200-111 DFB-LD module	
LN crystal cut specification	X-cut (The Z-cut option is a factory-installed option.)	Note 1
Optical insertion loss	7 dB typical, 10 dB max	Note 2
Maximum optical input	16 dBm	
Performance-guaranteed optical input range	9-13 dBm	Notes 3 and 5
Extinction ratio	AQ2200-621: 12 dB or higher at 1550 nm AQ2200-622: 12 dB or higher at 1310 nm	Notes 3, 4, and 6
Tr/Tf (20-80%)	25 ps or less	Notes 3 and 4
Electric input amplitude	500 mVpp ± 100 mVpp (AC coupling)	Note 3
Absolute maximum input amplitude	1200 mVpp (AC coupling)	
Electric connector	3.5 mm (jack) equivalent	
Optical connector (LD IN)	SC/PC fixed	
Optical connector (OPT OUT)	SC/PC standard (The FC/PC option is a factory-installed option.)	Note 1
Optical fiber	PMF is used inside the module. (The slow axis and key direction are matched.) PMF or SMF can be connected to the module.	

Note 1: Select one or the other (select when placing order).
 Note 2: Modulation loss due to NRZ code (50% mark rate) is included.
 Note 3: Use the AQ2200-601 BERT module optical modulator DATA OUT output and AQ2200-111 DFB-LD module (option PMF). For connections between modules, use the specified U link (optional) and PMF (optional). For the waveform observation trigger, use the AQ2200-601 10GHz CLOCK OUT. For optical waveform observation, use SMF with a length of one meter or less.
 Note 4: The performance-guaranteed temperature range is 23°C ±5°C.
 Note 5: This specifies the range in which Auto-Bias Control is stable.
 Note 6: These specifications are for the performance-guaranteed optical input range.
 (The specifications are for NRZ and PRBS31 (50% mark ratio) code unless otherwise specified.)

Specifications

Item	Specification	Remarks
Storage temperature	-10°C to 50°C, 80% relative humidity or less, with no condensation	
Operating temperature	5°C to 40°C, 80% relative humidity or less, with no condensation	
Wavelength range	1290-1330 nm, 1530-1570 nm	
Minimum optical receiver sensitivity	Less than -15 dBm at 1550 nm Ex=12 dB, 9.953 Gbit/s, PRBS31 Less than -14 dBm at 1310 nm Ex=12 dB, 9.953 Gbit/s, PRBS31	Notes 1 and 2
Maximum optical input	6 dBm peak, 3 dBm average	
Overload	-1 dBm or higher	Notes 1 and 2
Saturation output amplitude	300 mVpp or higher (AC coupling)	Note 1
Electric connector	3.5 mm (jack) equivalent	
Optical connector	SC/PC standard (The FC/PC option is a factory-installed option.)	Note 3
Optical fiber	SMF	

Note 1: Use the AQ2200-601 BERT module optical modulator DATA OUT (PPG setting) and DATA IN (ED setting); the AQ2200-111 DFB-LD module (option PMF); and the AQ2200-621/622 optical modulator. For connections between modules, use the specified U link (optional) and PMF (optional). The specifications are based on a loopback connection using SMF with a length of one meter or less.
 Note 2: The performance-guaranteed temperature range is 23°C ±5°C.
 Note 3: Select one or the other (select when placing order).
 (The specifications are for NRZ and PRBS31 (50% mark ratio) code unless otherwise specified.)

Applications

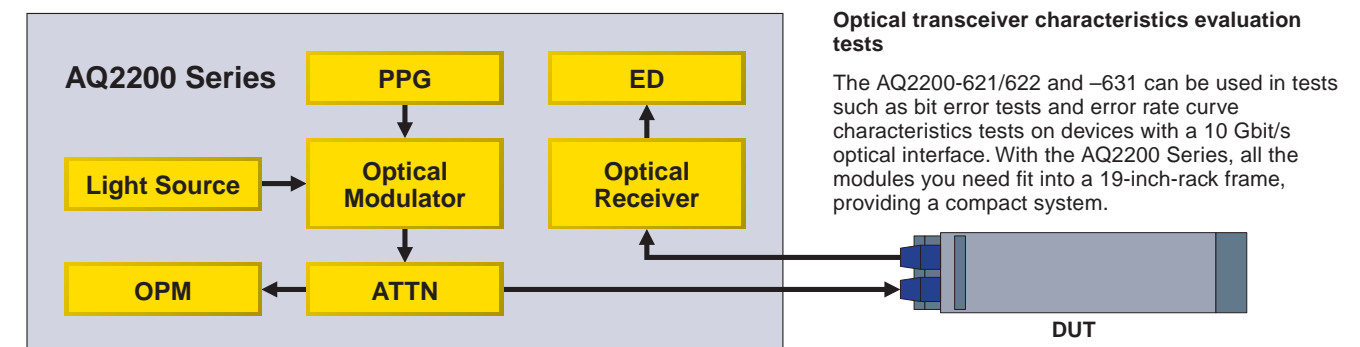

Model Numbers

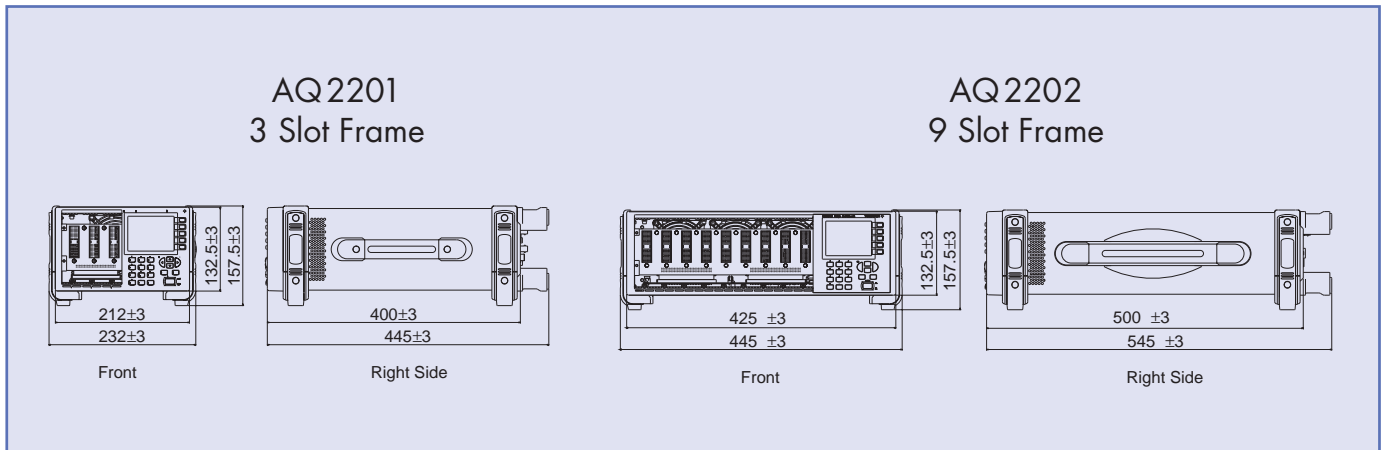

Model

Product	Model	Remarks
AQ2201 frame controller	810518900	-□ -M: Domestic standard, 2/3 pin adapter included -D: UL3P power cord -F: CEE-C7 power cord -G: SAA-3P power cord -Q: BS3P square -H: BS3P round
AQ2202 frame controller	810518920	-□ -M: Domestic standard, 2/3 pin adapter included -D: UL3P power cord -F: CEE-C7 power cord -G: SAA-3P power cord -Q: BS3P square -H: BS3P round
AQ2200-601 10 Gbit/s BERT module	810518801	/M: 64 Mbit program pattern
AQ2200-621 10 Gbit/s optical modulator (1.55μm)	810518802	-□-□ -A: X-cut -B: Z-cut -S: SC output connector -F: FC output connector /P: Connecting PMF (FC-SC), for 1.5 μm /U: U link coaxial cable

Product	Model	Remarks
AQ2200-622 10 Gbit/s optical modulator (1.31 μm)	810518804	-□-□ -A: X-cut -B: Z-cut -S: SC output connector -F: FC output connector /P: Connecting PMF (FC-SC), for 1.3 μm /U: U link coaxial cable
AQ2200-631 10 Gbit/s optical receiver (1.31/1.55 μm)	810518803	-□ -S: SC output connector -F: FC output connector /U: U link coaxial cable
AQ2200-111 DFB-LD module (Note 1)	810518901	-□-□-□-□-□ -□: Wavelength (Note 2) -FCA: Optical output connector FC/ Angled PC -P10: Optical output 10 mW -P20: Optical output 20 mW -SMF: SM fiber -PMF: PM fiber -MODN: No external modulation -MODS: External modulation (sine) -MODC: External modulation (chop)

Note: Pursuant to the Foreign Exchange and Foreign Trade Control Law, Japanese government approval may be required to export this product from Japan.
The information presented in this bulletin is subject to change without notice due to performance and quality improvements.

Note



Pursuant to the Foreign Exchange and Foreign Trade Control Law, Japanese government approval may be required to export this product from Japan.
The information presented in this bulletin is subject to change without notice due to performance and quality improvements.

YOKOGAWA

YOKOGAWA ELECTRIC CORPORATION
Communication & Measurement Business Headquarters /Phone: (81)-422-52-6768, Fax: (81)-422-52-6624
E-mail: tm@csv.yokogawa.co.jp

YOKOGAWA CORPORATION OF AMERICA Phone: (1)-301-916-0409, Fax: (1)-301-916-1498
YOKOGAWA EUROPE B.V. Phone: (31)-33-4641858, Fax: (31)-33-4641859
YOKOGAWA ENGINEERING ASIA PTE. LTD. Phone: (65)-62419933, Fax: (65)-62412606

Subject to change without notice.
[Ed : 01/b] Copyright ©2005
Printed in Japan, 505(KP)